



# HOW TO ASSEMBLE

HARMONY™ 6x8 / 2x2.5

## IMPORTANT!

Please read these instructions carefully before starting assembly.  
Keep these instructions in a safe place for future reference.

[www.canopia.com](http://www.canopia.com)



A member of  
Palram Industries Ltd.



87768\_2112\_MV-1.2



# 4 WAYS TO WATCH OUR VIDEO



## 1 Scan QR Code



## 2 Search on YouTube



Palram - Canopia  
Harmony Assembly



## 3 Go to

<http://bit.ly/2htO0FG>

## 4 Visit us

<https://canopia.com/product-category/greenhouses/>



# 1

## PARTS REQUEST

**In the case of missing or damaged parts, do not return product to store.**

Go to the link below or scan the QR code for help, it will direct you to a form that will help us assist you as soon as possible.



SCAN ME

Contact us on our website:  
[bit.ly/3js7yZi](https://bit.ly/3js7yZi)

# 2

## ASSEMBLY ASSISTANCE

If you need any technical assistance in assembling your product, go to the link below or scan the QR code for help. It will direct you to a form that will help us assist you as soon as possible.



SCAN ME

Contact us on our website:  
[bit.ly/3kqqFEc](https://bit.ly/3kqqFEc)



## CUSTOMER SUPPORT



SCAN ME

# WE ARE HERE TO HELP

For general questions: [bit.ly/3kY07dP](https://bit.ly/3kY07dP)

### USA



877-627-8476



[hobbyservice@poly-tex.com](mailto:hobbyservice@poly-tex.com)

### CANADA



905-5646007



[sales@footprintproducts.com](mailto:sales@footprintproducts.com)

### UNITED KINGDOM · IRELAND



01302-380775



[customer.serviceUK@palram.com](mailto:customer.serviceUK@palram.com)

### GERMANY



0180-522-8778



[customer.serviceDE@palram.com](mailto:customer.serviceDE@palram.com)

### FRANCE · BELGIUM



+33-169-791-094



[customer.serviceFR@palram.com](mailto:customer.serviceFR@palram.com)

### ISRAEL



04-848-6816



[info.il@palram.co.il](mailto:info.il@palram.co.il)

### ITALY · NETHERLANDS · PORTUGAL · SPAIN



+33-169-791-094



[customer.serviceFR@palram.com](mailto:customer.serviceFR@palram.com)

### AUSTRIA · LUXEMBURG · LIECHTENSTEIN



+49-180-522-8778



[customer.serviceDE@palram.com](mailto:customer.serviceDE@palram.com)

### AUSTRALIA



03-9219-4444



[salesvic@palram.com](mailto:salesvic@palram.com)

NORWAY · SWEDEN · ARGENTINA · GREECE · GREENLAND · ICELAND · ESTONIA · JAPAN · LATVIA · LITHUANIA  
MAURITIUS · MEXICO · ROMANIA · RUSSIA · TURKEY · UZBEKISTAN · UKRAINE · SWAZILAND · KOREA



+972-4-848-6816



[customer.service@palram.com](mailto:customer.service@palram.com)



## CUSTOMER SUPPORT



SCAN ME

# WE ARE HERE TO HELP

For general questions: [bit.ly/3kY07dP](https://bit.ly/3kY07dP)

### AUSTRALIA - GREENHOUSES

 03-9544-6-999

 [info@mazedistribution.com.au](mailto:info@mazedistribution.com.au)

### HUNGARY · SLOVAKIA

 +420-493-523-523

 [servis@garland.cz](mailto:servis@garland.cz)

### NEW ZEALAND

 0800 800 880

 [customer.service@palram.com](mailto:customer.service@palram.com)

### DENMARK

 07-575 42 70

 [post@nshnordic.com](mailto:post@nshnordic.com)

### SOUTH AFRICA

 011-397-7771

 [receptionza@palram.com](mailto:receptionza@palram.com)

### CROATIA · SLOVENIA

 0599-37-057

 [info@ms-viscom.com](mailto:info@ms-viscom.com)

### CZECH REPUBLIC

 0493-523-523

 [servis@garland.cz](mailto:servis@garland.cz)

### FINLAND

 Neuvonta: 09-6866720  
Tuki / Varaosat: 050-3715350

 [www.horisontenterprises.fi](http://www.horisontenterprises.fi)  
[tuki@horisontenterprises.fi](mailto:tuki@horisontenterprises.fi)

### POLAND

 Infolinia: 801-011-929  
22-349-93-36

 [kontakt@ogrodosfera.pl](mailto:kontakt@ogrodosfera.pl)

### CYPRUS

 0224-971-13

 [alpaco@alpacodomica.com](mailto:alpaco@alpacodomica.com)  
[www.alpacodomica.com](http://www.alpacodomica.com)

### SWITZERLAND

 062-287-33-77

 [info@ritter.ch](mailto:info@ritter.ch)



## BASE DIMENSIONS HARMONY

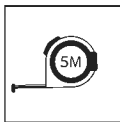
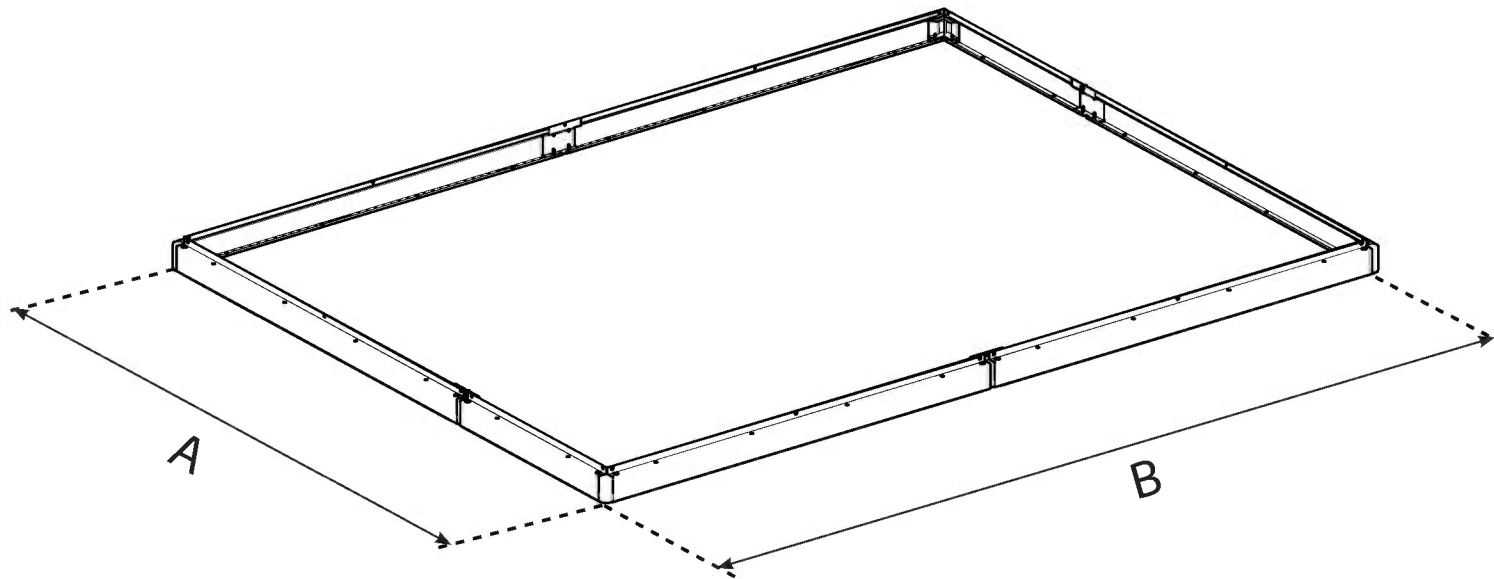

MODEL	WIDTH		LENGTH	
6x8 / 2x2.5	A	185 cm / 6'1"	B	246 cm / 8'1"

# SITE PREPARATION & FOUNDATION

## A - PREPARE THE SITE

The product must be positioned and fixed on a flat level surface.

### 1 - Clear the site

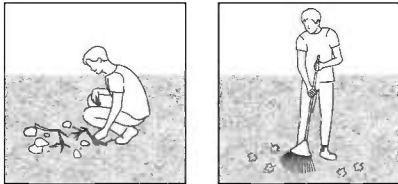

### 2 - Level the ground

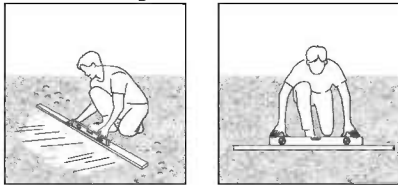

### IMPORTANT

We recommend checking for restrictions or covenants for building this product in your area. In addition we advise to check if you need to submit any forms or if any permit is required prior to building the product.

## B - CHOOSE YOUR FOUNDATION TYPE

For a foundation, we recommend using three material types :  
Concrete / Pressure treated wood / wood deck / Paver blocks

### Option 1: Solid foundation

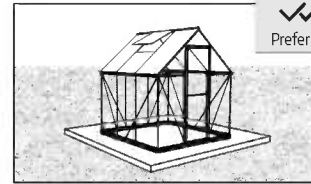
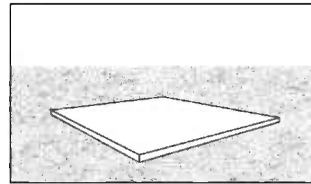

### Option 2: Solid frame

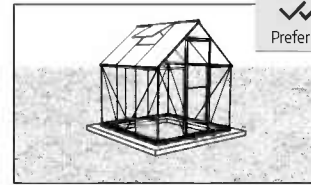
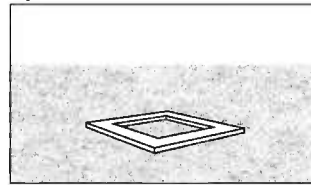

### Option 3: Firm ground / grass

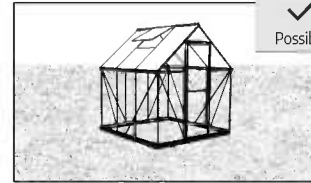

\* The size of the greenhouse displayed is for illustration purposes only and may not reflect the size of your greenhouse.

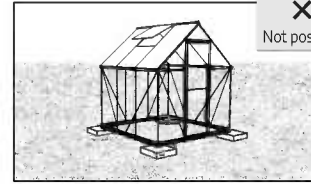

## C - ANCHOR TO FOUNDATION

### On a solid foundation / frame

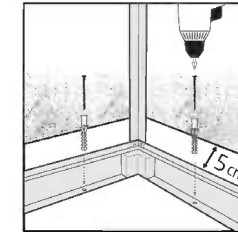

Secure the product to the foundation of your choice using suitable screws & plugs or masonry anchors (not supplied).

Make sure you have at least 5 cm / 2" between the product base and the edges of your foundation - **on all sides.**

### On soil / grass

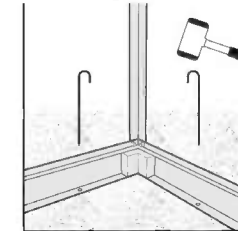

Secure the product to the ground surface using suitable long pegs (not supplied).

Please consult with an expert regarding which fasteners are suitable for other surface types.

## SAFETY ADVICE

- It is of utmost importance to assemble all of the parts according to the directions. Do not skip any steps.
- Always wear work gloves during panel sliding.
- Always wear shoes and safety goggles when working with extruded aluminium.
- If using a step ladder or power tools make sure that you follow the manufacturer's safety advice.
- Do not touch overhead power cables with the aluminium profiles.
- Do not attempt to assemble the product in windy or wet conditions.
- Dispose of all plastic bags. Keep them out of reach of small children.
- Keep children away from the assembly area.
- Do not lean against or push the products during construction.
- Do not position your product in an area exposed to excessive winds.
- Do not attempt to assemble this product if you are tired, have taken drugs or alcohol or if you are prone to dizzy spells.
- Hot items such as recently used grills, blowtorches etc. must not be stored in the product.
- Make sure there are no hidden pipes or cables in the ground before anchoring to foundation.
- This product is designed to be used mainly as a greenhouse.
- **Make sure to anchor the product directly to a solid foundation to increase the product's stability and wind resistance in areas with severe weather conditions. Make sure that there are no obstructions between the assembly area and the final position of the product. The Palram - Canopia Anchoring kit is available for purchase separately.**

## CARE & MAINTENANCE

- When your product needs to be cleaned, use a mild detergent solution and rinse with cold clean water.
- DO NOT use acetone, abrasive cleaners or other special detergents to clean the panels.
- Clean the product once assembly is complete.

## TOOLS & EQUIPMENT

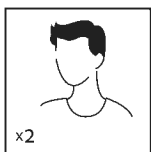

2 people needed

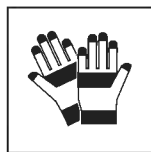

Work gloves

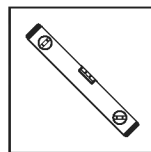

Spirit Level

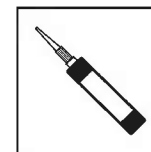

Silicone



Rubber Mallet

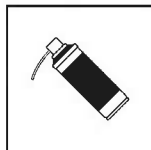

Lubricant Spray

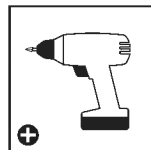

Cordless drill  
Phillips head

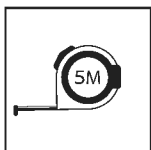

Tape measure

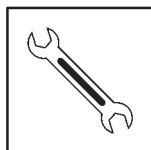

Wrench  
10 mm | 13/32"

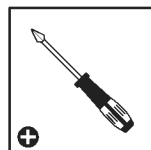

Phillips head  
Screwdriver



## BEFORE ASSEMBLY

1. Selecting a site:
  - Choose your site carefully before beginning assembly.
  - Choose a sunny position away from overhanging trees.
  - The product must be positioned and fixed on a flat level surface.
2. The product must be secured directly to a solid foundation.
3. This is a multi-part assembly best achieved by two people. Allow at least half a day for the assembly process.
4. Take all components & parts out of the packages. Sort the parts and check against the content parts list.
5. Parts should be laid out close at hand. Keep all small parts (screws etc.) in a bowl so they do not get lost.
6. Please note multi-sided profiles are used in this product. As a result some holes in the profiles are not used during assembly.
7. Please review entire instructions before starting. Carry out the assembly steps in exact order.
8. Please consult your local authorities if any permits are required prior to constructing the product.

## IMPORTANT!

- Firmly connect the product to a level surface immediately after completion of the assembly.
- Anchoring this product to the ground is essential to its stability and rigidity. It is required to complete this stage in order for your warranty to be valid.
- During assembly use a soft surface below the parts to avoid scratches and damages.

## DURING ASSEMBLY

- During assembly, you will encounter different icons for different products. Please see below for more information:



- During assembly you will encounter the information icon, please refer to the relevant assembly step for additional comments and assistance.



- You may use silicone lubricant spray on the frame in order to help you slide the panels into the profiles. Do not spray the panels.



- Use a rubber mallet if necessary.

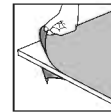

- Make sure you remove covering plastic film from both sides of the panel.

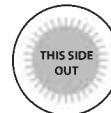

- All panels with the stamped words "THIS SIDE OUT" must be facing out to create full UV protection. Remove plastic sticker as panels are locked in place.



- This icon indicates that the installer should be inside the product.



- This icon indicates that the installer should be outside the product.



- Steps marked with dashed outlines refer to Extensions only.
- Some of the steps are irrelevant for an assembly of a single product.
- When assembling a single or an extended product, some parts may be surplus.

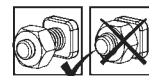

- These 2 icons below indicate if screw's tightening is required or not.
- Temporary tightening of a few screws may be needed to prevent a profile from sliding out.



- Tighten all screws once assembly is completed.



## IMPORTANT ASSEMBLY STEPS

**When encountering this information icon during assembly, please refer to the relevant assembly step for important additional comments.**

**Step 6:** Determines the front side of the greenhouse.

**Steps 10, 16, 19:** The oval hole in the crossbars. **#256** should always be assembled to the base of the greenhouse.

**Steps 12-13:** In order to insert profile **#8378** in between two **#7311 & #7310** profiles, please apply silicone lubricant spray.

### Door Assembly:

Can be installed as a left hand door or right hand door to your decision. These instructions show a right hand door assembly.

**Step 14:** Determines door direction door post **#7311** is where door hinges will be located.

**Steps 57-65:** Door assembly should be done according to this decision.

## Window Assembly

**Steps 39+40:** Decide on the window's location before assembly. Window can be installed in one of the indicated options.

Once the window location is chosen, please turn **part #7316** into the correct position accordingly.

**Step 56:** In case the window is not closed properly, please go to **Step 42**, release the screws, adjust the profile and tighten the screw.

# PRÉPARATION DU TERRAIN ET FONDATIONS

## A- PRÉPARER LE TERRAIN

Le produit doit être positionnée et fixée sur une surface plane.

### 1- Déblayer le terrain

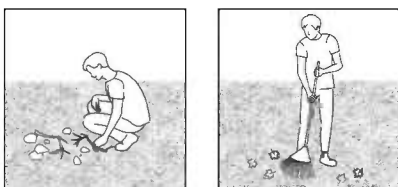

### 2- Nivelier le sol

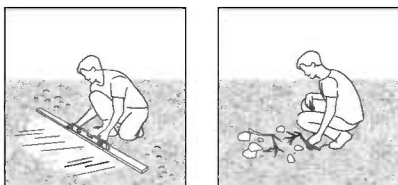

### IMPORTANT

Avant d'assembler ce produit dans votre région, nous vous recommandons de vous renseigner sur les restrictions ou réglementations locales. Nous vous conseillons en outre de vérifier si vous devez soumettre des formulaires ou si un permis est requis avant de monter le produit.

## B - CHOISIR VOTRE TYPE DE FONDATIONS

Pour la fondations, nous recommandons d'utiliser trois types de matériaux : Béton / Bois traité sous pression / plancher en bois / Blocs de pavés.

### Option 1 : Une fondation solide

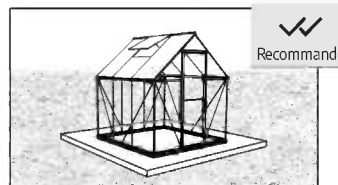
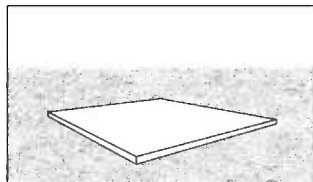

### Option 2 : Un cadre rigide

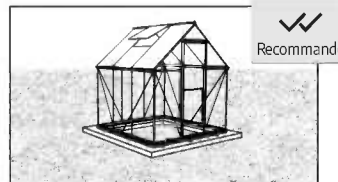
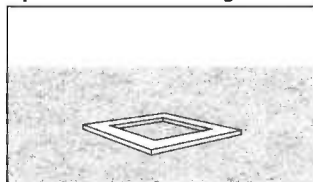

### Option 3 : Terre / pelouse ferme

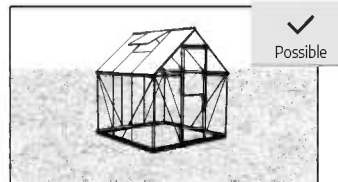

\*La taille de la serre affichée ici est uniquement à titre d'illustration et ne reflète pas forcément la taille de votre serre.

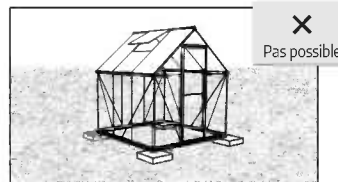

## C - ANCRAGE A LA FONDATIONS

### Sur une fondations solide / cadre

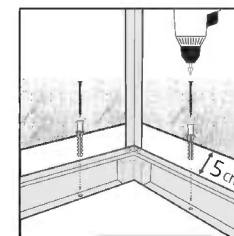

Fixez le produit à la fondation de votre choix, à l'aide de vis et de chevilles appropriées ou d'ancrages en maçonnerie (non fournis).

Assurez-vous qu'il y a au moins 5 cm entre la base du produit et le périmètre de votre fondation - **de tous les côtés**.

### Sur la terre ou l'herbe

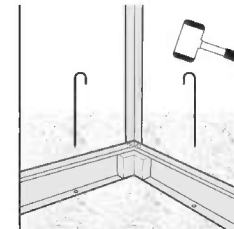

Fixez le produit à la surface du sol à l'aide de longs piquets appropriés (non fournis).

Demandez à un expert quels éléments de fixation conviennent à un autre type de surface.

## CONSEILS DE SECURITE

- Très important ! Veuillez suivre scrupuleusement les instructions de ce manuel et réaliser les étapes dans l'ordre énoncé.
- Nous recommandons vivement le port de gants de protection pendant le montage.
- Portez toujours des chaussures de travail et des lunettes de protection lorsque vous travaillez des pièces en aluminium extrudé.
- Lors de l'utilisation d'une échelle ou d'outils électriques, assurez-vous de bien suivre les consignes de sécurité du fabricant.
- Veillez à ne pas toucher de câbles aériens avec les profilés en aluminium.
- N'essayez pas de monter la produit s'il y a du vent ou s'il fait humide.
- Jetez tous les sacs en plastique en appliquant les règles de sécurité et maintenez-les hors de portée des jeunes enfants.
- Eloignez les enfants de la zone d'assemblage.
- Ne vous appuyez pas contre la produit et ne la poussez pas pendant le montage.
- Ne positionnez pas la produit dans un endroit trop exposé au vent.
- N'essayez pas de monter la produit si vous êtes fatigué, si vous êtes sous l'effet de drogues, de médicaments ou d'alcool ou encore si vous êtes sujet aux vertiges.
- Les objets chauds tels qu'un barbecue, un chalumeau ou autre article ayant été récemment utilisés, ne doivent pas être rangés dans la produit.
- Assurez-vous qu'il n'y a pas de tuyaux ou de câbles cachés dans le sol avant d'ancrer à la fondation.
- Ce produit a été conçu pour être principalement utilisé comme serre.
- **Assurez-vous d'ancrer le produit directement sur une surface solide pour augmenter sa stabilité et sa résistance au vent, en particulier dans les zones soumises à des conditions météorologiques extrêmes. Veillez à ce qu'il n'y ait pas d'obstacles entre la zone de montage et la position finale du produit. Le kit d'ancrage Palram - Canopia est disponible à l'achat séparément.**

## ENTRETIEN & MAINTENANCE

- Pour nettoyer votre produit, utilisez une solution détergente douce et rincez à l'eau claire et froide.
- NE PAS utiliser d'acétone ni de produits nettoyants ou autres détergents spéciaux pour nettoyer les panneaux clairs.
- Nettoyez le produit une fois le montage termine.

## OUTILS ET ÉQUIPEMENT

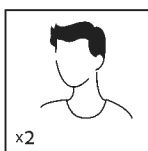

Nécessite  
2 personnes

x2



Gants de travail

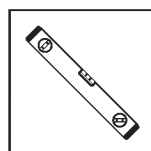

Niveau



Silicone

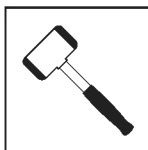

Maillet en  
caoutchouc

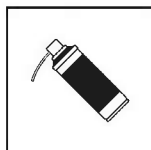

Spray lubrifiant

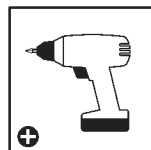

Perceuse  
Tête Philips

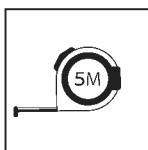

Mètre

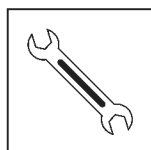

Clé  
10 mm | 13/32"



Tournevis cruciforme

## AVANT L'ASSEMBLAGE

1. Choisir un endroit :
  - Choisissez votre site avec soin avant de commencer l'assemblage.
  - Choisissez un endroit ensoleillé loin des arbres en saillie.
  - La produit doit être positionnée et fixée sur une surface plane.
2. Le produit doit être fixé directement sur une surface solide
3. Il s'agit d'un assemblage multi parties qu'il vaut mieux réaliser à deux. Comptez au moins une demi journée pour le processus de montage.
4. Retirez tous les composants des paquets. Triez les éléments et vérifiez la liste.
5. Les éléments doivent se trouver à portée de main. Gardez tous les petits éléments (vis etc.) dans un bol pour ne pas les perdre.
6. Veuillez noter que des coupes multi faces sont utilisées dans cette produit. C'est pourquoi certains trous dans les coupes ne sont pas utilisés pendant le montage.
7. Veuillez vérifier toutes les instructions avant de commencer. Procédez aux étapes de montage dans l'ordre exact.
8. Veuillez consulter les autorités locales au cas où des permis sont nécessaires pour la construction du produit.

## IMPORTANT!

- Connectez du produit fermement à une surface nivelée après l'achèvement de l'assemblage.
- L'ancrage du produit au sol entielle à sa stabilité et à sa rigidité, il est de plus nécessaire pour assurer la validité de votre garantie.
- Pendant le montage, placez une surface souple sous les pièces pour éviter de les érafler ou de les endommager.

## DURANT L'ASSEMBLAGE

- Lors du montage, vous trouverez différentes icônes correspondant à différents produits. Pour de plus amples informations, veuillez vous référer à ce qui suit:



- Pendant le montage, vous verrez l'icône d'information, veuillez-vous référer à la phase de montage correspondante pour des commentaires et une assistance supplémentaires.



- Vous pouvez utiliser un spray de lubrifiant pour silicone afin de vous aider à glisser les panneaux dans les profilés. Ne pulvérisez pas les panneaux.



- Utilisez un maillet en caoutchouc si nécessaire.

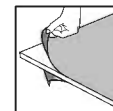

- Assurez-vous de retirer le film plastique couvrant des deux côtés du panneau.

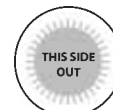

- Tous les panneaux estampillés "THIS SIDE OUT" doivent être orientés vers l'extérieur pour assurer une protection UV intégrale. Retirez les stickers en plastique quand les panneaux sont verrouillés et bien en place.



- Cette icône indique que l'installateur doit être à l'intérieur du produit.



- Cette icône indique que l'installateur doit être en dehors du produit.



- Les étapes marquées en pointillés ne concernent que les extensions.
- Certaines étapes ne sont pas nécessaires pour l'assemblage d'un produit unique.
- Lors de l'assemblage d'un produit unique ou d'une extension, il peut rester des pièces.

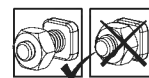

- Ces 2 icônes indiquent s'il est nécessaire de serrer les écrous ou non.



- Il peut être nécessaire de serrer temporairement certaines vis pour empêcher un profilé de se déplacer.
- Serrez toutes les vis une fois l'assemblage terminé.



## PRINCIPALES ÉTAPES D'ASSEMBLAGE

Lorsque vous rencontrez cette icône d'information pendant l'assemblage, veuillez vous référer à l'étape d'assemblage correspondante pour d'autres commentaires importants.

**Étape 6:** Identifier le côté avant de la serre

**Étapes 10, 16, 19:** Le trou ovale dans les barres fixes #256 doit toujours être monté à la base de la serre.

**Étapes 12-13:** Afin d'insérer le profil #8378 entre les profils #7311 et #7310, veuillez appliquer un lubrifiant à base de silicone.

### Assemblage de la porte:

La porte peut être installée à gauche ou à droite, selon votre choix. Ces instructions montrent une installation de porte à droite.

**Étape 14:** Déterminer la direction de la porte. Le montant de la porte #7311 est l'endroit où les charnières de la porte seront installées.

**Étapes 57-65:** L'installation de la porte doit être effectuée conformément à cette décision.

## Assemblage de la fenêtre

**Étapes 39+40:** Choisissez l'emplacement de la fenêtre avant le montage. La fenêtre peut être assemblée dans l'une des options indiquées. Une fois l'emplacement de la fenêtre choisi, veuillez tourner la pièce #7316 dans la bonne position en conséquence.

**Étape 56:** Si la fenêtre n'est pas correctement fermée, veuillez passer à l'étape 42, desserrer les vis, ajuster le profil et ensuite serrer les vis.

# PREPARACIÓN DEL SITIO Y CIMENTACIÓN

## A - PREPARE EL SITIO

El producto debe colocarse y fijarse en una superficie plana y nivelada.

### 1 - Limpie el sitio

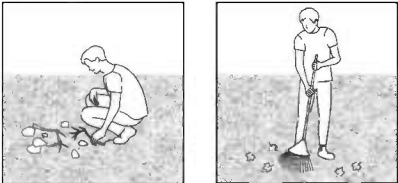

### 2 - Nivele el terreno

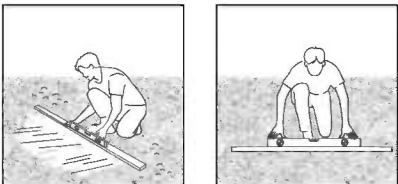

### IMPORTANTE

Recomendamos comprobar las restricciones o convenios para la construcción de este producto en su área. Además, aconsejamos comprobar si necesita presentar algún formulario o si se requiere algún permiso antes de construir el producto.

## B - ELIJA EL TIPO DE CIMENTACIÓN

Como cimentación, recomendamos usar tres tipos de materiales: Hormigón / Madera prensada / Piso de madera / Adoquín de hormigón.

### Opción 1: cimentación sólida

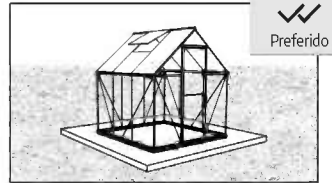
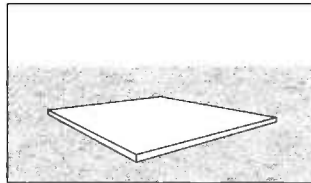

### Opción 2: Estructura sólida

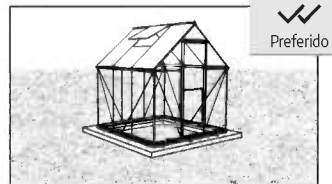
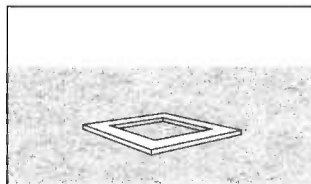

### Opción 3: Tierra firme / césped

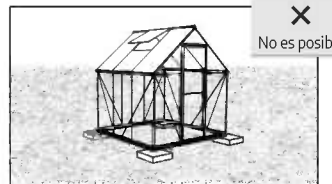
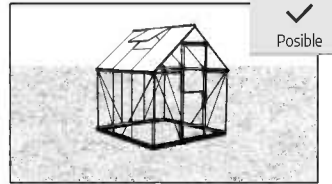

\* El tamaño del invernadero que se muestra tiene un propósito meramente ilustrativo y puede no reflejar el tamaño de su invernadero.

## C - ANCLAJE A LOS CIMIENTOS

### Sobre una cimentación sólida / estructura

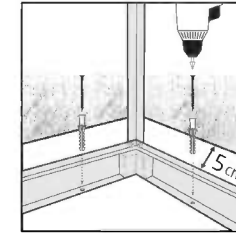

Asegure el producto a los cimientos de su elección, usando tornillos y tacos adecuados o anclajes de mampostería (no incluidos).

Asegúrese de tener al menos 5 cm | 2" entre la base del producto y el perímetro de su cemento - **en todos los lados.**

### Sobre tierra / césped

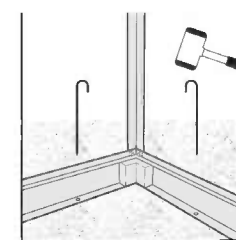

Asegure el producto a la superficie del terreno usando clavijas largas y adecuadas (no incluidos).

Pregunte a un experto qué elementos de fijación son adecuados para otro tipo superficie.

## CONSEJOS DE SEGURIDAD

- Es de suma importancia montar todas las partes de acuerdo con las instrucciones. No se salte ningún paso.
- Recomendamos firmemente el uso de guantes de trabajo durante el montaje.
- Use siempre zapatos y gafas de seguridad al trabajar con aluminio extruido.
- Al usar una escalera plegable o herramientas eléctricas asegúrese de que sigue las instrucciones de seguridad de los fabricantes.
- No toque los cables eléctricos aéreos con los perfiles de aluminio.
- No intente montar el invernadero en días de viento o días con humedad.
- Disponga todas las bolsas plásticas en lugar seguro - guárdelas fuera del alcance de niños.
- Mantenga a los niños fuera del área de montaje.
- No se apoye ni empuje el producto durante la construcción.
- No coloque su producto en un área expuesta al viento excesivo.
- No intente montar este producto si usted está cansado, ha tomado drogas o alcohol o si usted es propenso a ataques de mareo.
- Artículos calientes recientemente usados tales como parrillas, sopletes etc. no deben ser almacenados en el producto.
- Asegúrese de que no hay tuberías o cables ocultos en el suelo antes de anclar a los cimientos.
- Este producto fue diseñado para ser utilizado principalmente como un Cobertizo de jardín.
- **Asegúrese de anclar el producto directamente a una base sólida para aumentar su estabilidad y resistencia al viento, especialmente en áreas con condiciones climáticas severas. Asegúrese de que no haya obstáculos entre la zona de montaje y la posición final del producto. El kit de anclaje de Palram - Canopia puede adquirirse por separado.**

## CUIDADOS & MANTENIMIENTO

- Cuando precise limpiar su producto, use una solución de detergente suave y aclare con agua limpia fría.
- NO use acetona, limpiadores abrasivos u otros detergentes especiales para limpiar los paneles transparentes.
- Limpie el producto una vez terminado el montaje.

## HERRAMIENTAS Y EQUIPOS

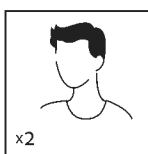

Se necesitan dos personas



Guantes de trabajo

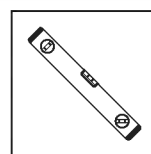

Regla de nivel



Silicona

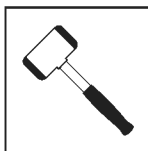

Martillo de goma

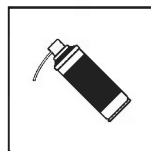

Aceite en aerosol

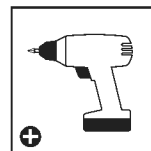

Taladro inalámbrico: cabeza Philips

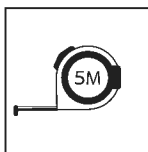

Cinta métrica

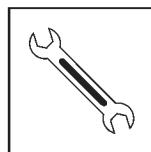

Llave 10 mm | 13/32"

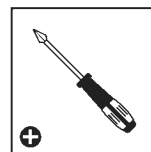

Destornillador de cabeza Philips



## ANTES DEL MONTAJE

1. Seleccionar un lugar:
  - Elija su sitio cuidadosamente antes del ensamblaje inicial.
  - El producto debe colocarse y fijarse en una superficie plana y nivelada.
  - Escoja una ubicación soleada y apartada de árboles que la cubran.
2. El producto debe fijarse directamente a una superficie sólida.
3. Este montaje consta de varias partes y sería óptimo que lo realizaran dos personas. El proceso de montaje llevará alrededor de medio día.
4. Extraiga todas las piezas de componentes de sus embalajes. Ordene las piezas y compruebe que están todas usando la lista de contenidos.
5. Las piezas deberían colocarse cerca y tenerlas a mano. Ponga las piezas pequeñas (p. ej. tornillos) en un bol para no perderlas.
6. Por favor, tenga en cuenta que este producto incluye perfiles con múltiples superficies. Como resultado, algunos de los agujeros de los perfiles no se utilizan durante el montaje.
7. Por favor, revise todas las instrucciones antes de empezar. Siga los pasos del montaje en el orden exacto.
8. Consulte las limitaciones, requisitos, permisos y a las autoridades locales para la construcción de este cobertizo de jardín.

## ¡IMPORTANTE!

- Conecte firmemente el producto a una superficie nivelada inmediatamente después de terminar el montaje.
- Anclar este producto al suelo es esencial para su estabilidad y rigidez. Es necesario completar esta fase para que su garantía sea válida.
- Durante el montaje, ponga algo suave por debajo de las piezas, para evitar que se rayen o estropeen.

## DURANTE EL MONTAJE

- Durante el montaje, se encontrará con diferentes iconos. Para obtener más información, consulte lo siguiente:



- Cuando encuentre el ícono de información, por favor lea con cuidado dicho paso con comentarios y asistencia adicionales.



- Puede utilizar spray lubricante de silicona para facilitar el deslizamiento de los paneles en los contornos. No ponga spray en los paneles.



- Use un martillo de goma si hiciera falta.

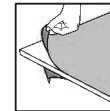

- Asegúrese de quitar la película plástica que cubre ambos lados del panel.

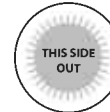

- Todos los paneles que tengan estampado LADO EXTERIOR (THIS SIDE OUT) deben mirar hacia fuera para ofrecer una protección UV completa. Quite la pegatina de plástico una vez los paneles se enganchen en su sitio.



- Este ícono indica que el instalador debe estar dentro del producto.



- Este ícono indica que el instalador debe estar fuera del producto.

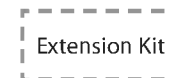

- Los pasos marcados con líneas discontinuas se refieren únicamente a las extensiones.

- Algunos de los pasos son innecesarios para el montaje de un solo producto.

- Durante el montaje de un producto individual o de una extensión, pueden sobrar algunas piezas.

- Los siguientes 2 íconos le indicarán si el ajuste de los tornillos es necesario o no.

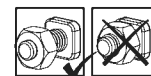

- en algún paso puede ser necesario apretar de forma temporal algunos tornillos para evitar que se caiga un perfil.

- Apriete todos los tornillos una vez esté completado el montaje



## PASOS DE MONTAJE IMPORTANTES

**Al encontrar este icono de información durante el montaje, consulte el paso de montaje correspondiente para obtener importantes comentarios adicionales.**

**Paso6:** Determina el lado frontal del invernadero.o

**Pasos 10, 16, 19:** El agujero ovalado en las barras transversales. #256 siempre debe ser montado en la base del invernadero.

**Pasos 12-13:** Para introducir el perfil #8378 entre los dos perfiles #7311 & #7310, por favor, aplique silicona paralubricarlo. Montaje de la puertala puerta.

### Montaje de la puerta:

La puerta puede ser instalada a la izquierda o a la derecha segim su decision. Estas instrucciones muestran montaje de una puerta a derecha.

**Paso 14:** Determina la direccion de la puerta al lado #7311 es donde se encuentran las bisagras de la puerta.

**Pasos 56-57:** Montaje de la puerta se debe hacer de acuerdo con esta decision.

### Montaje de la ventana:

**Pasos 39+40:** Decida la ubicacion de la ventana antes del montaje. La ventana puede instalarse en una de las opciones indicadas.



Una vez que se elija la ubicacion de la ventana, por favor, gire la pieza #7316 en la posicion correcta en el mismo modo.

**Paso 56:** en el caso de que la ventana no cierre adecuadamente, por favor, extraiga los tornillos, Paso 42 ajuste el perfil y apriete los tornillos.

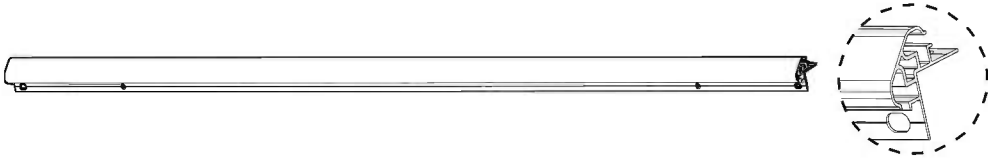
# Contents

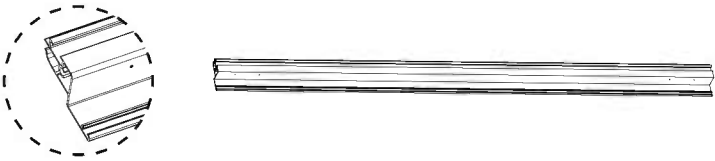
Item		Qty.
996		4



Item		Qty.
7309		4

983		1
993		14

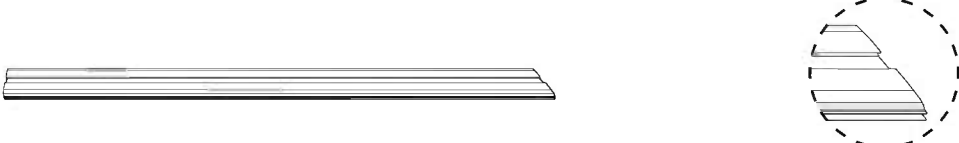
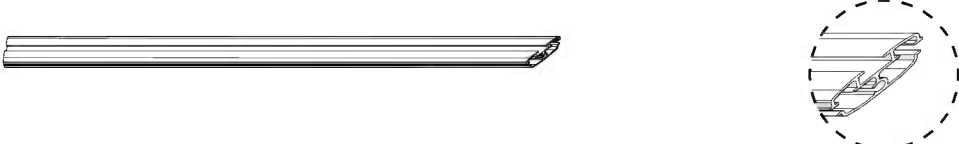
992		2
-----	---	---

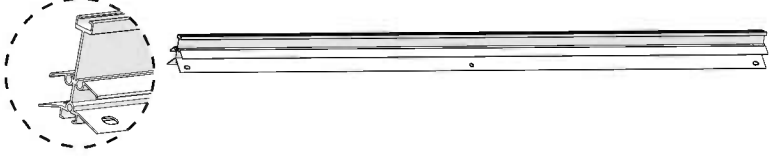
7312		1
7313		1

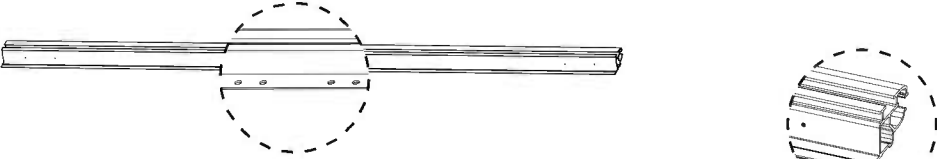
977		2
-----	---	---

7311		2
7310		2

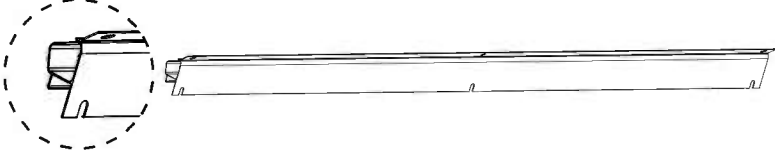
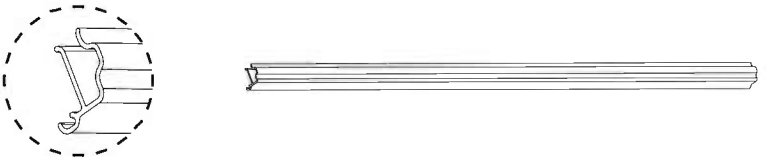
976		4
981		8

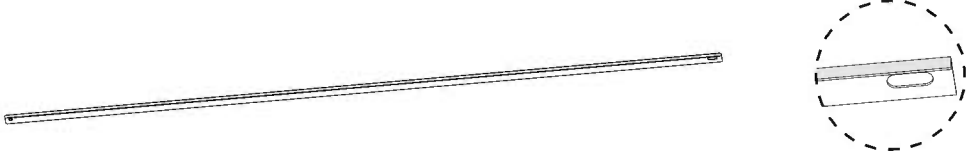
256		8
-----	--	---

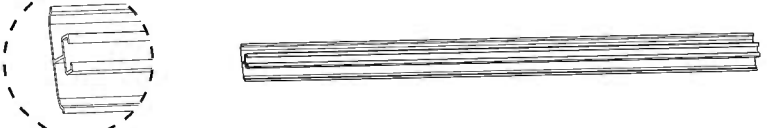
999		5
-----	---	---

# Contents

Item	Qty.
984 	2

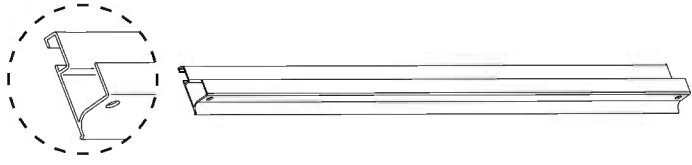
991 	1
---	---

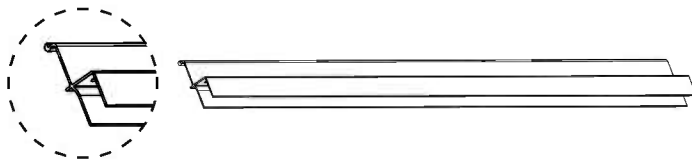
989 	1
---	---

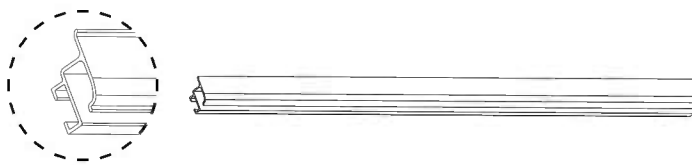
990 	1
--	---

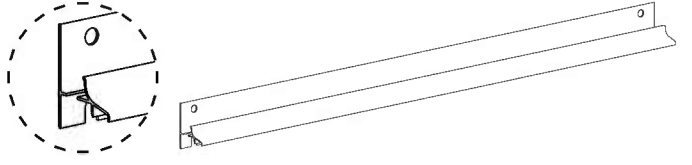
986 	1
---	---

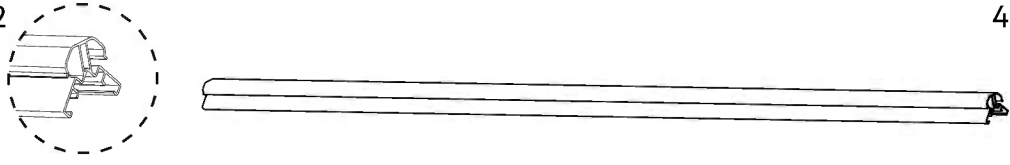
9802 	4
---	---

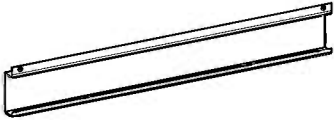
7596 	2
--	---

7597 	6
---	---

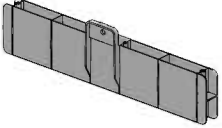
8447 	4
--	---

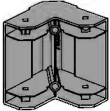
7602 	4
--	---

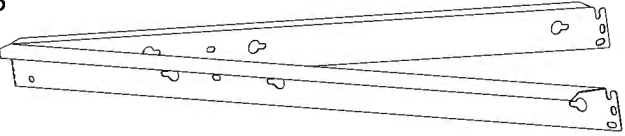
955 	1
---	---

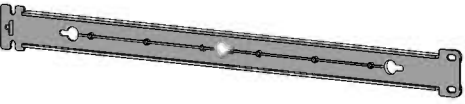
8549 	2
--	---

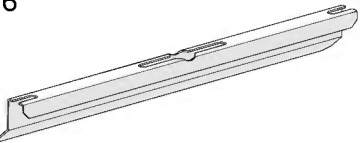
7316 	1
--	---

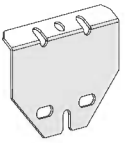
08 	2
--	---

8710 	3
--	---

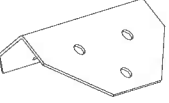
07 	1
--	---

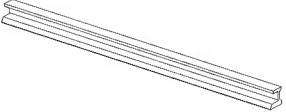
8378 	4
---	---

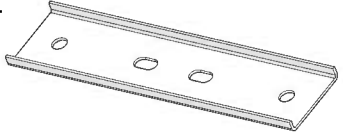
7314 	2
--	---

956 	1
---	---

# Contents



Item	Qty.
7011	20
7010	2
567	2
553	1
570	1
559	2
560	2

Item	Qty.
3017	2
3016	1

Item	Qty.
318	15 (+1)
7009	2 (+1)
329	6
292	2
344 L	2
344 R	2

Item	Qty.
343	2
328	19 (+8)
8797	1
8798	1
8801	1
8799	1
8800	1

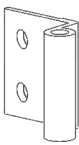
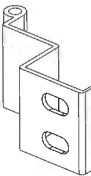
# Contents

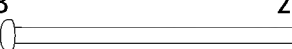
Item	Qty.
464 	4
462 	2
465 	8 (+1)
422 	8 (+1)
463 	2

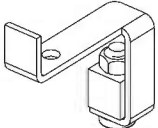
4037 	1
--	---

411 	129 (+10)
---	--------------

412 	130 (+9)
---	-------------

4008 	10 (+1)
--	------------

4045 	16 (+2)
--	------------

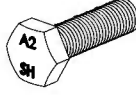

7442 	52 (+3)
--	------------

4043 	6 (+1)
--	-----------

410 	1
---	---

461 	2
---	---

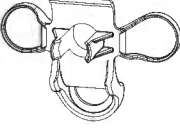
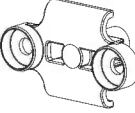
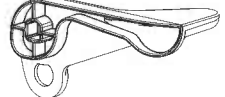
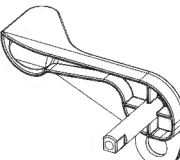
466 	2
---	---

Item	Qty.
7086 	1
7085 	1
7084 	1
7083 	1
7088  M4 x 50 mm	1
423 	1

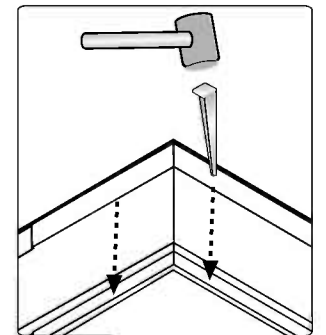
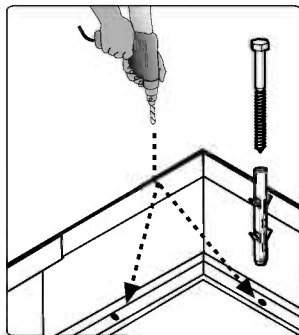
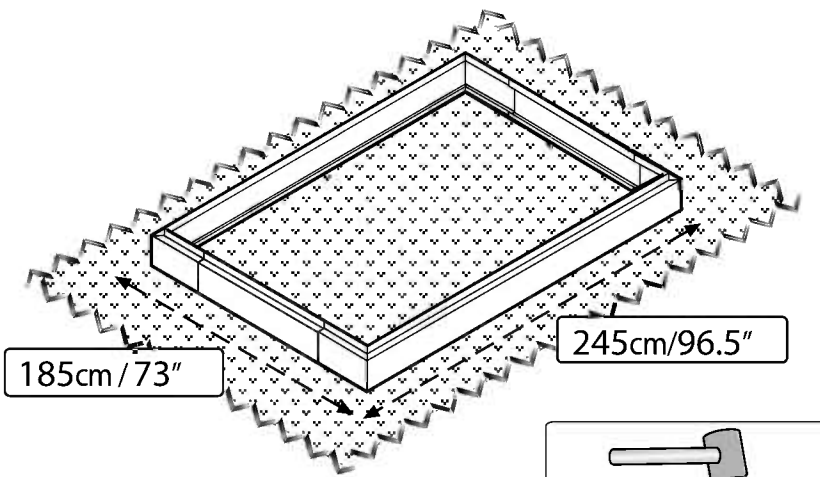
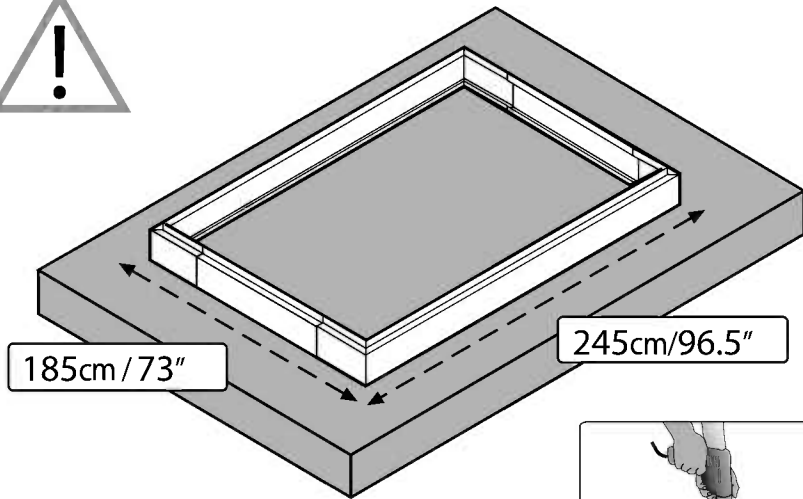
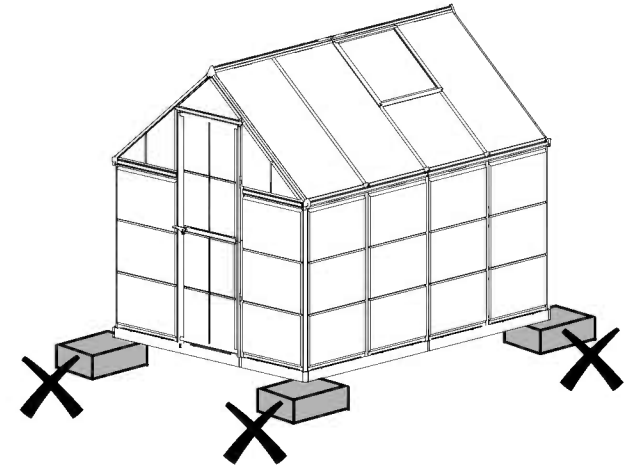
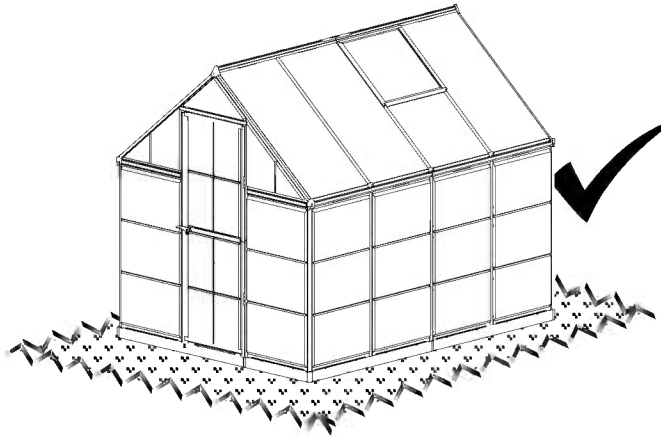
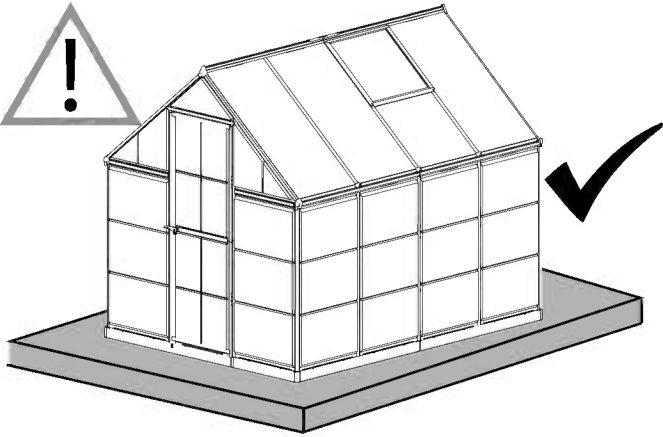

1

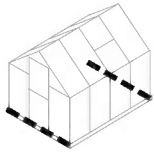

7596		.....2	8447		.....2	7442		.....24
7597		.....2	7602		.....4			

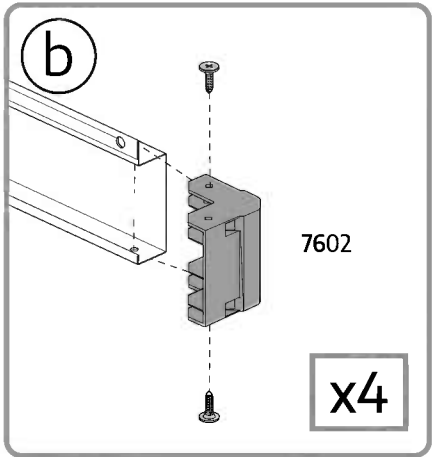
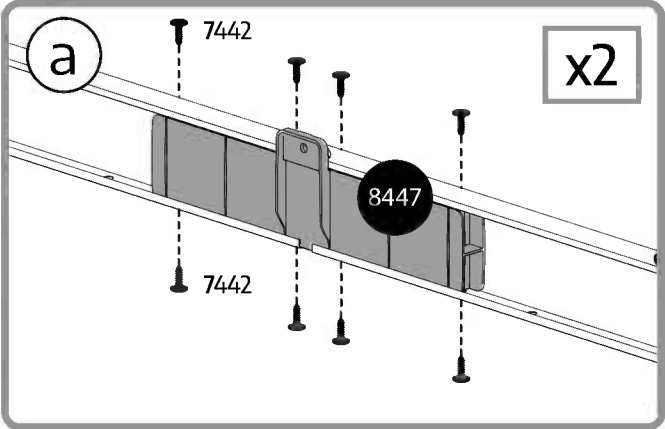
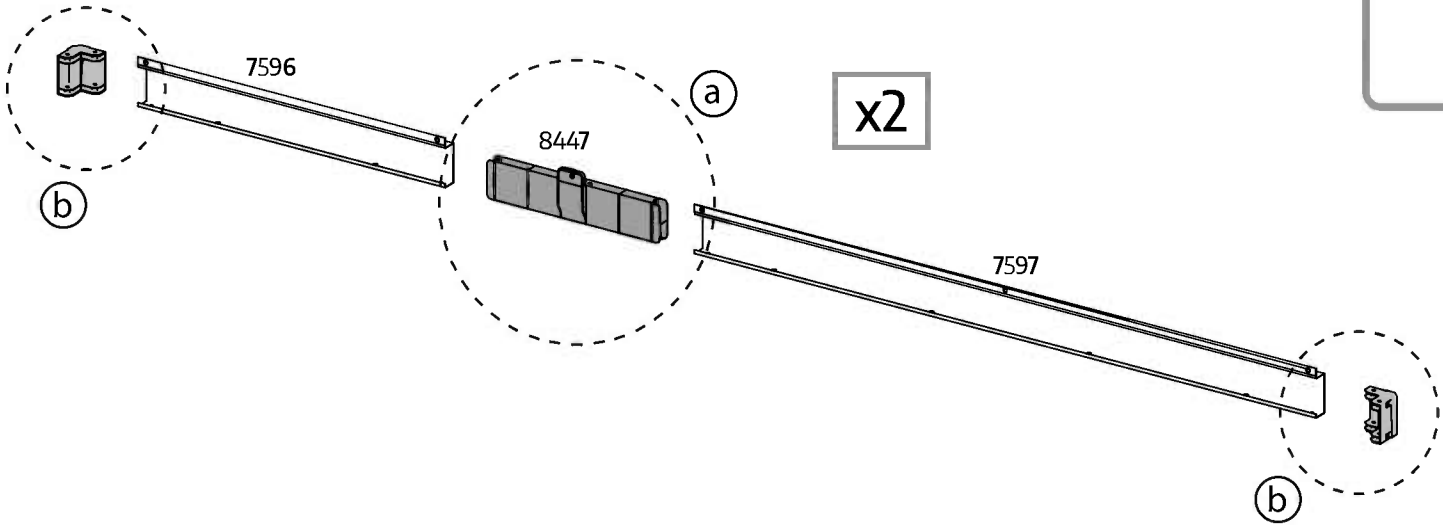



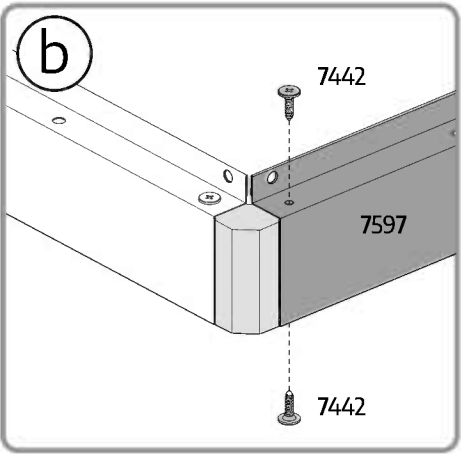
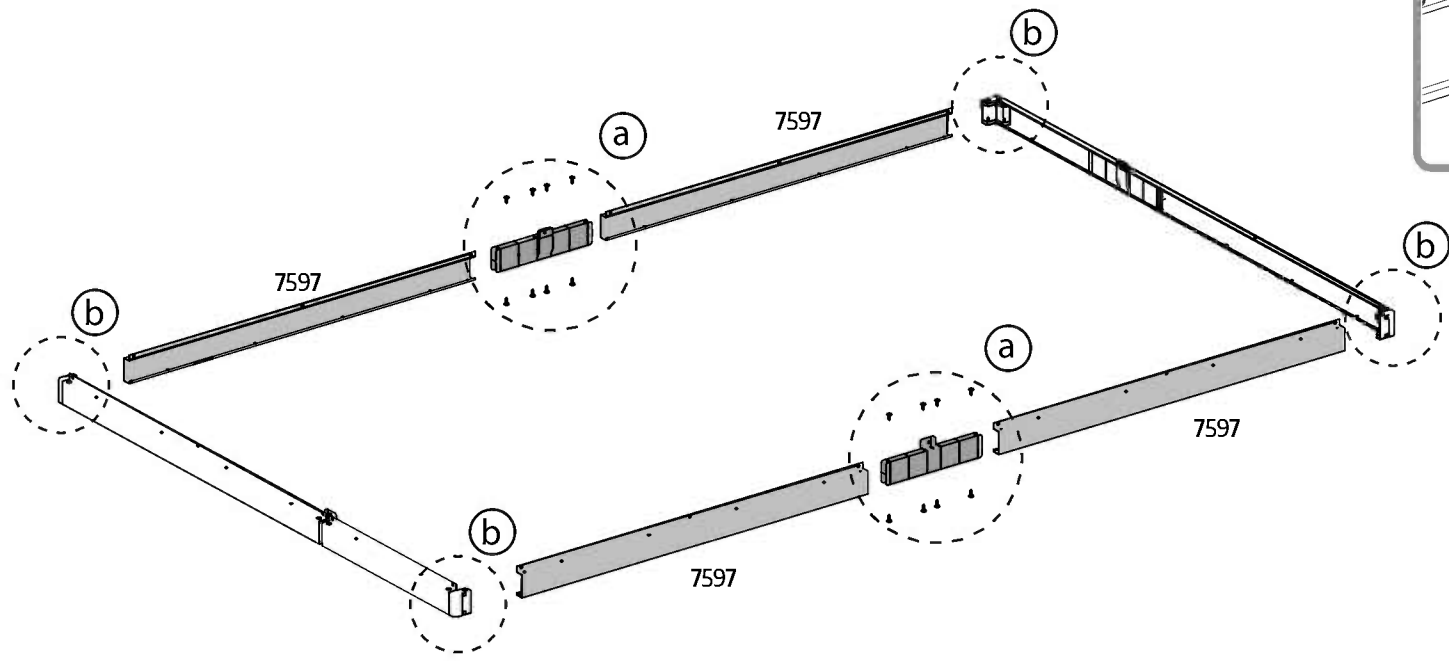
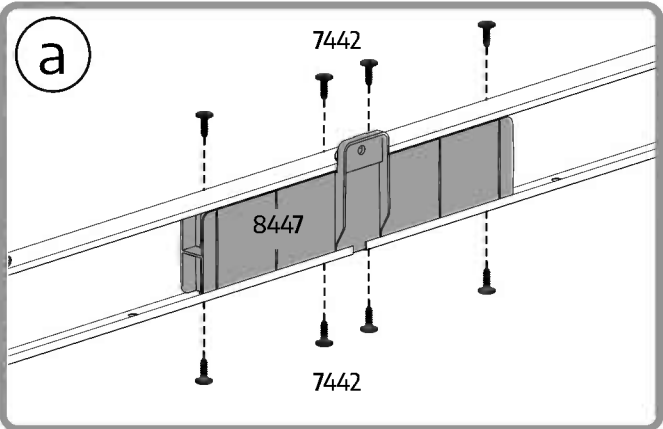
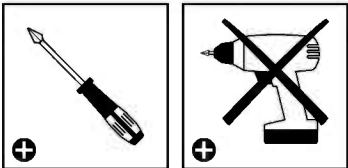
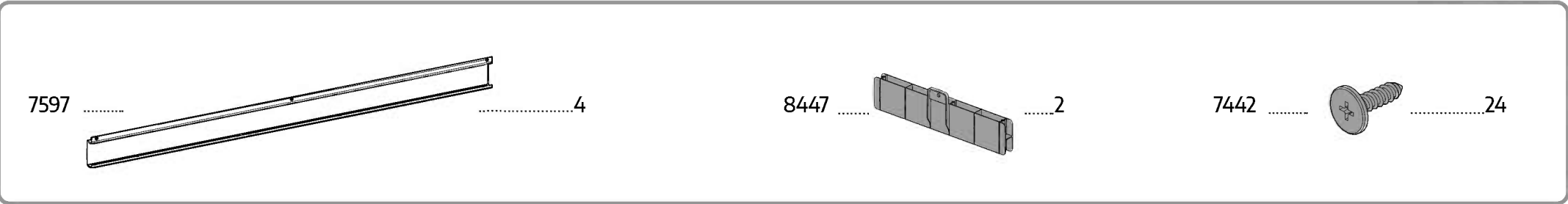
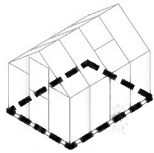

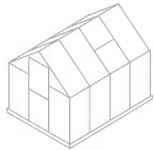

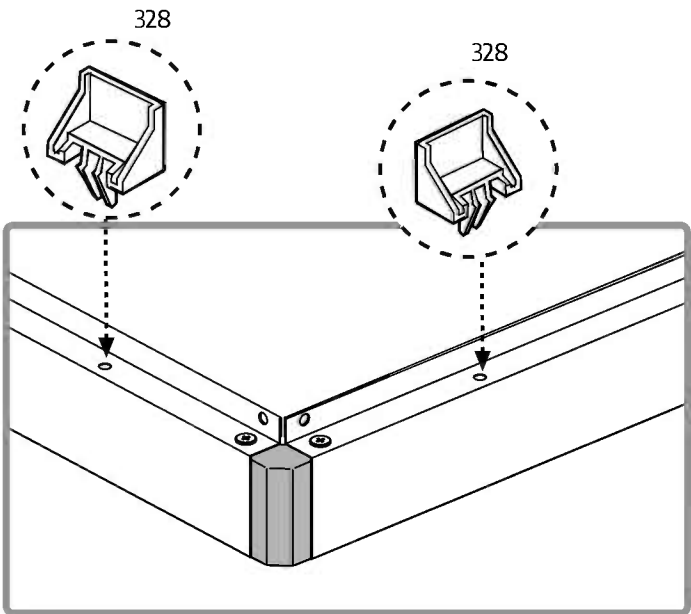
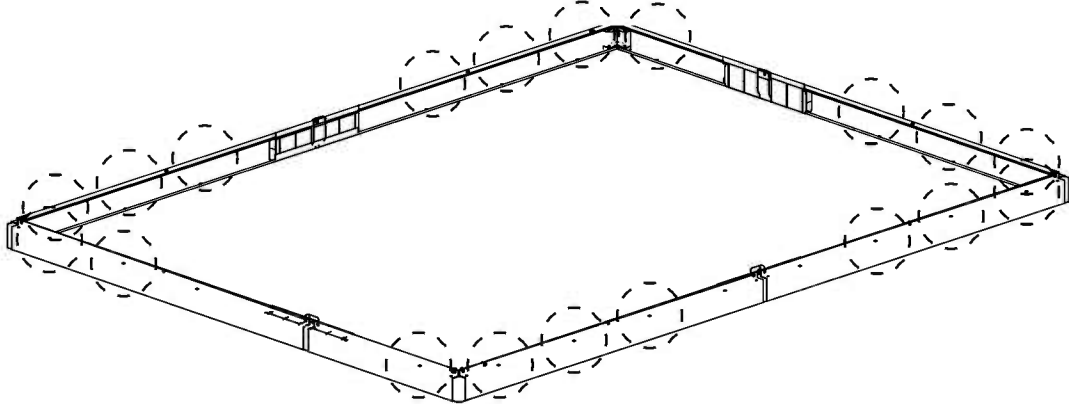
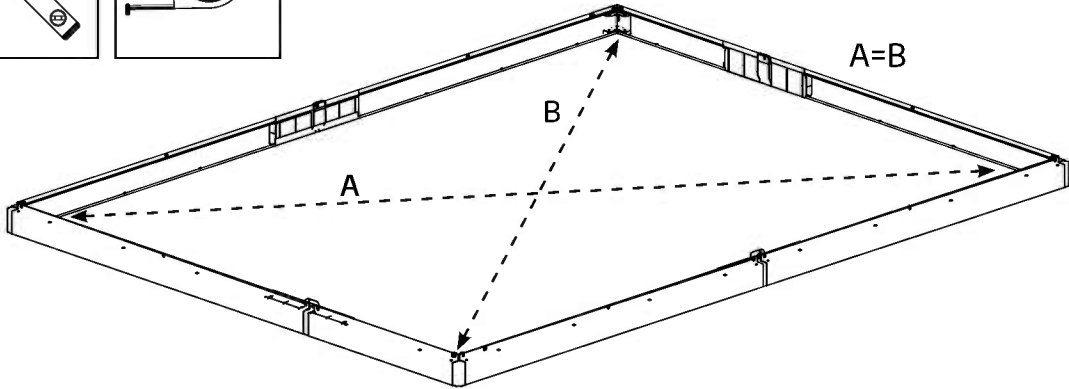
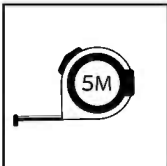
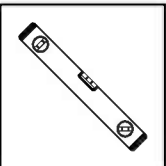
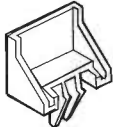

328 ..... 19

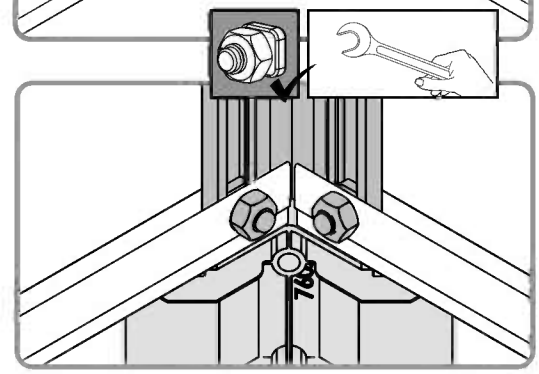
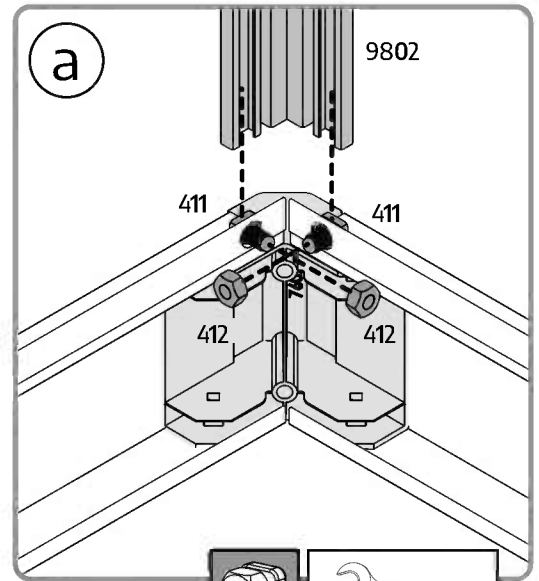
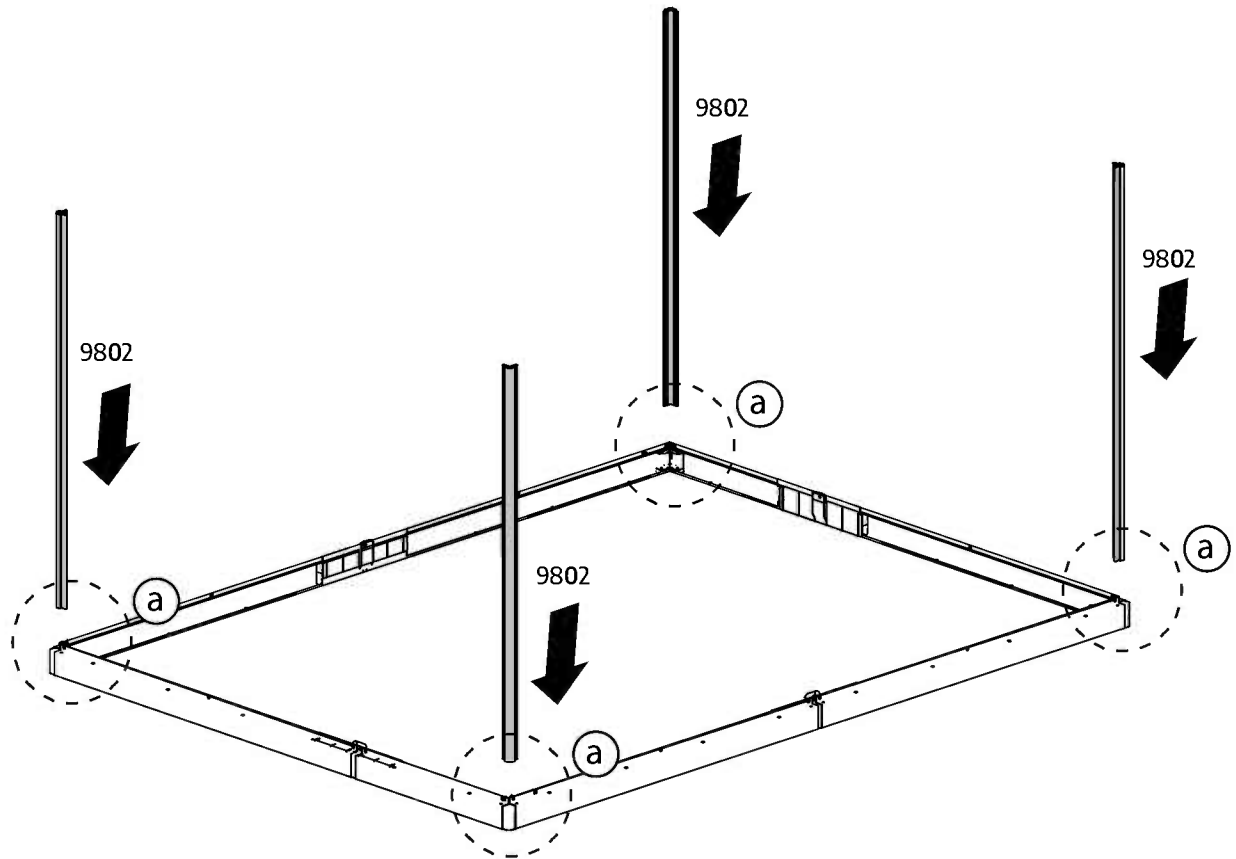
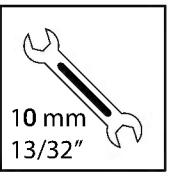
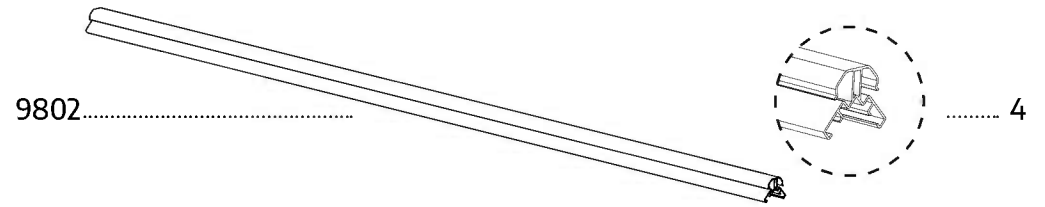
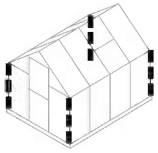

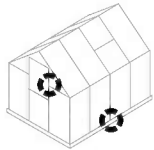



411 .....  .....10

412 .....  .....10

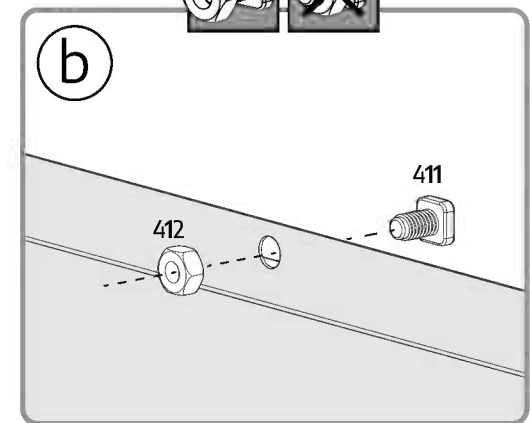
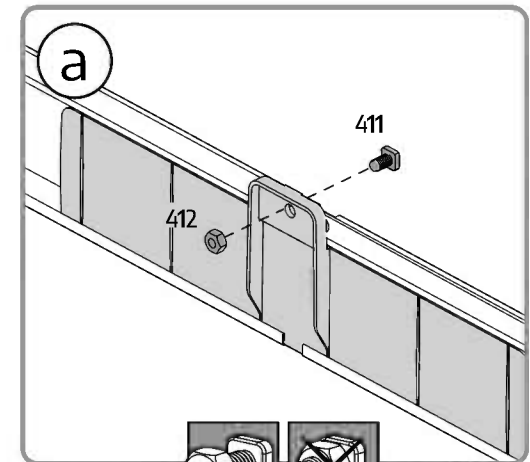
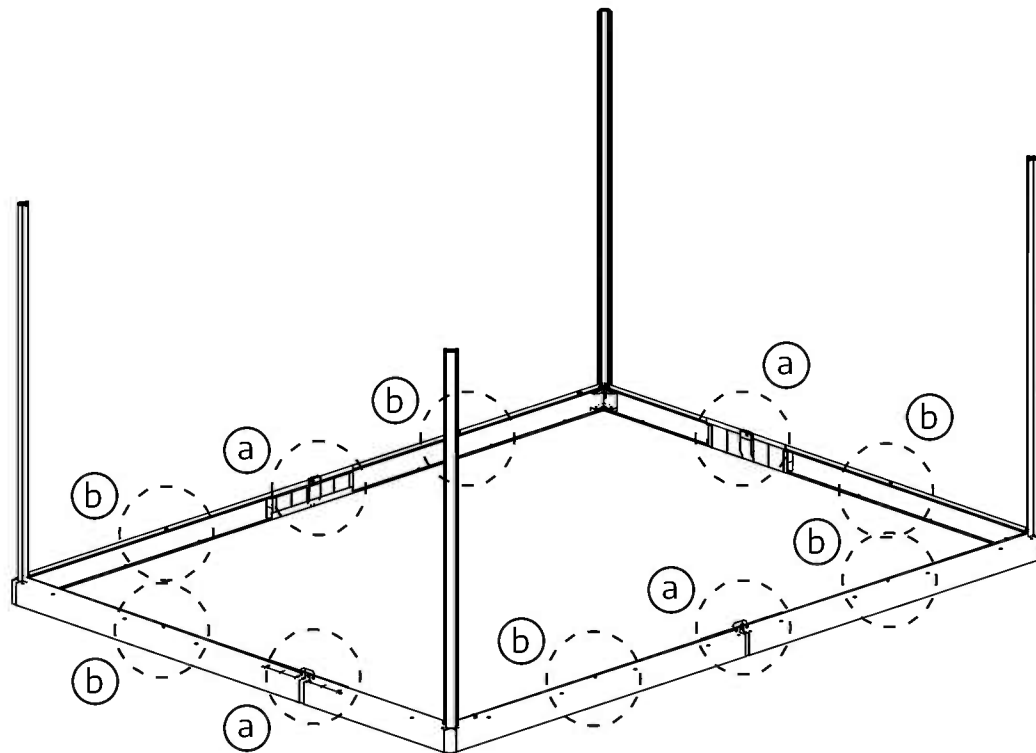

6



Determines the front side of the greenhouse.

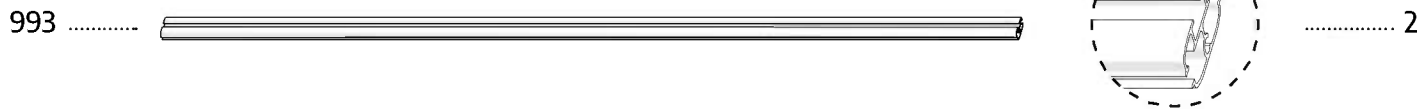
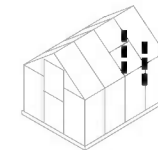

a

993

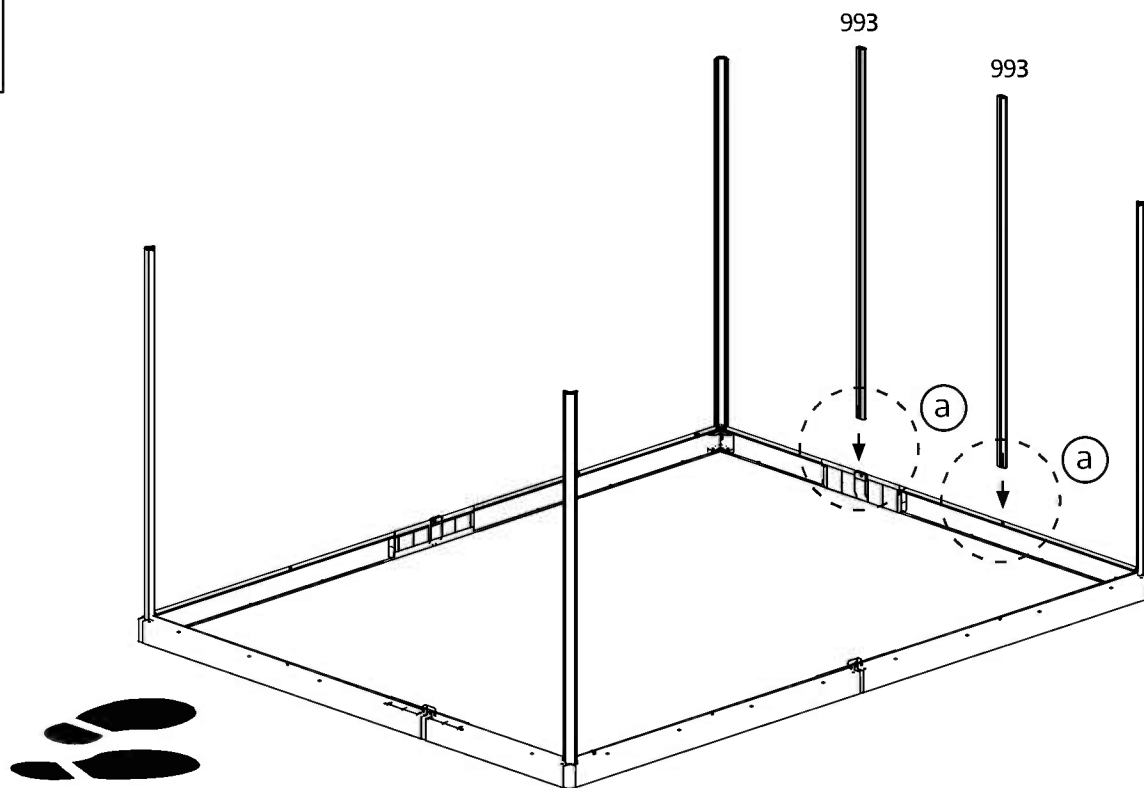
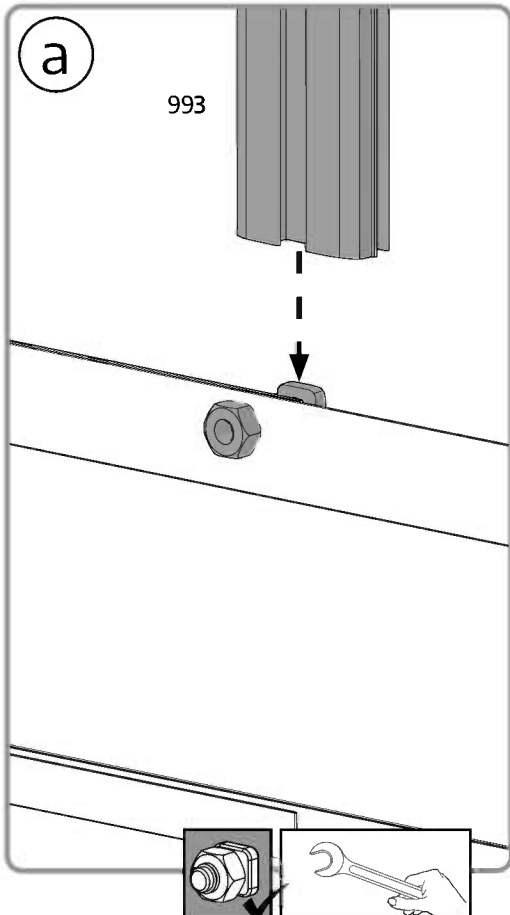
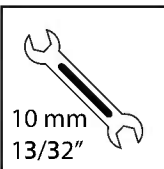

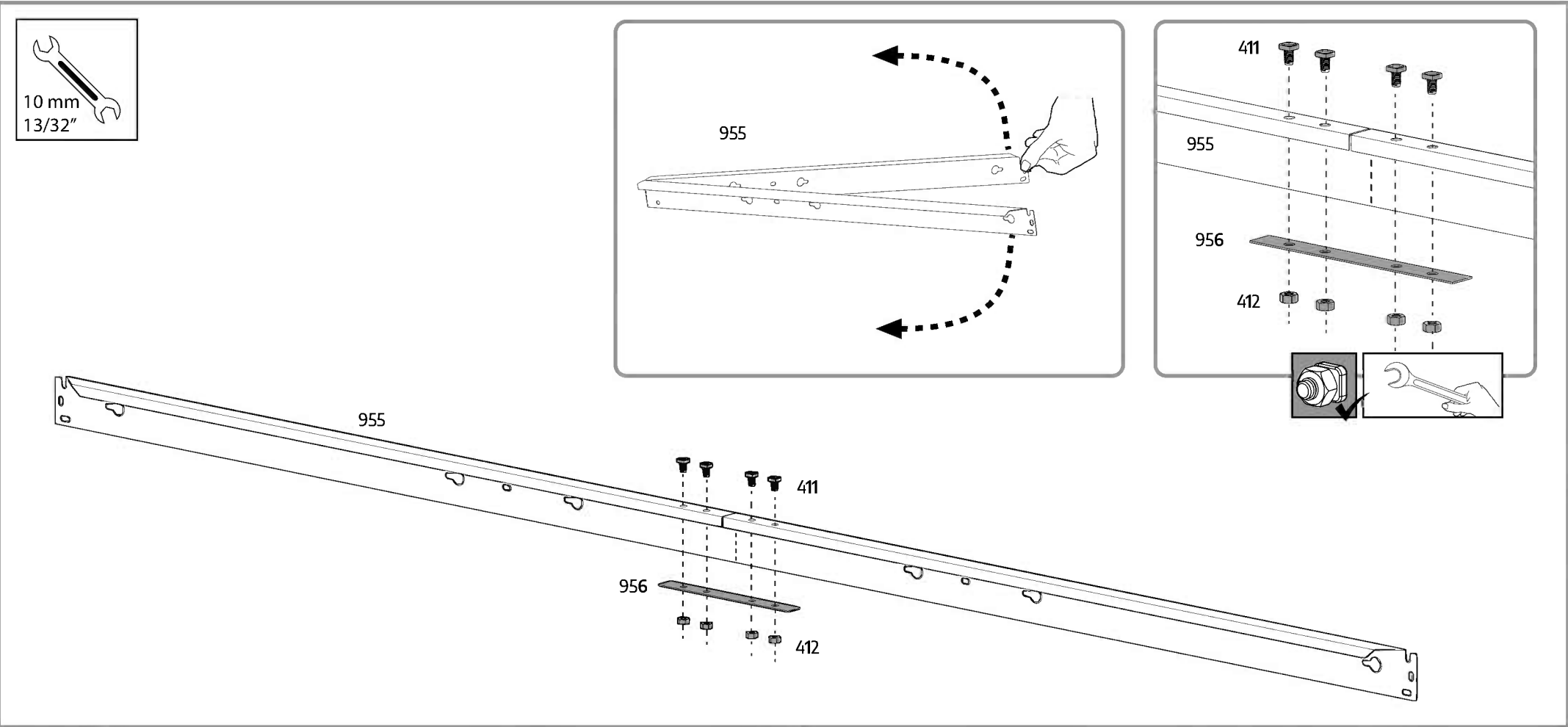
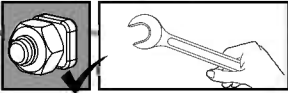
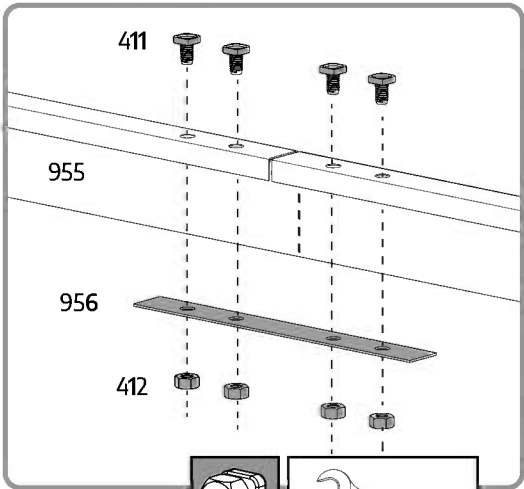
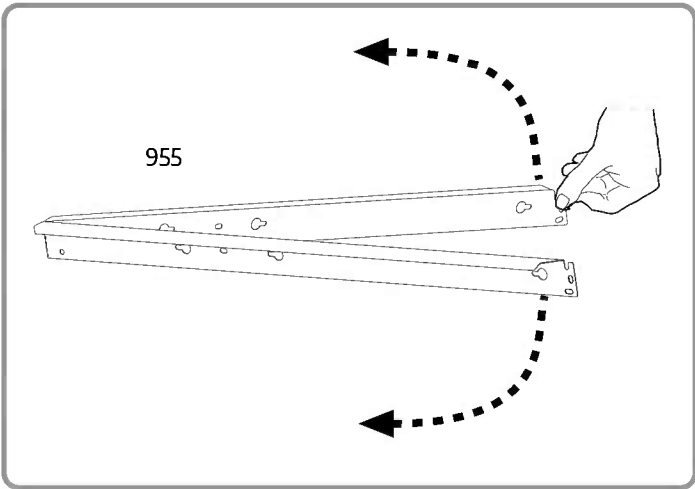
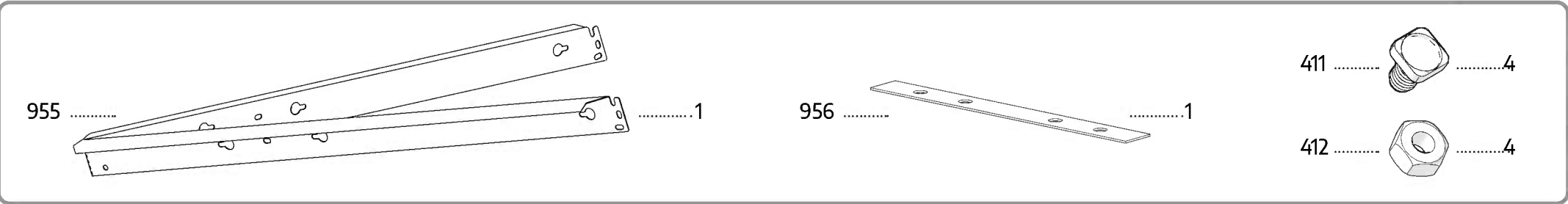
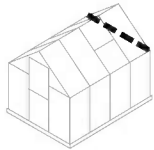

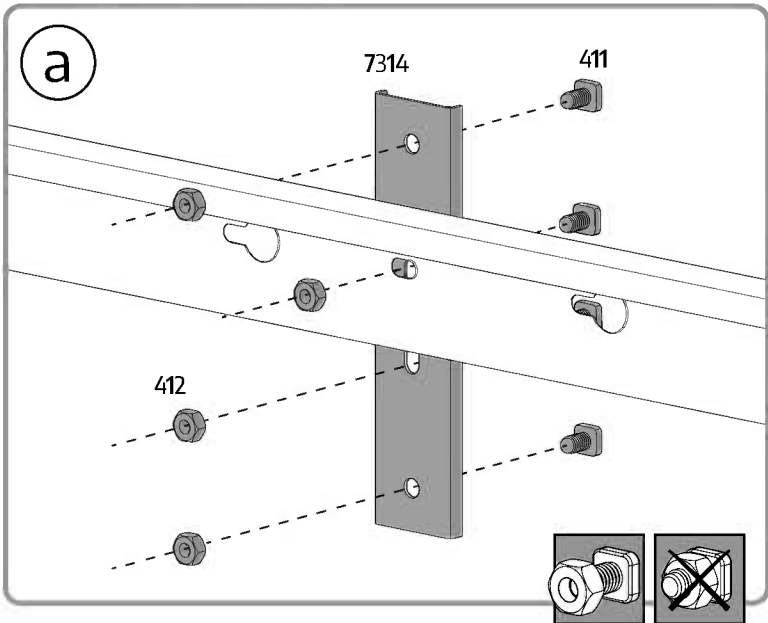
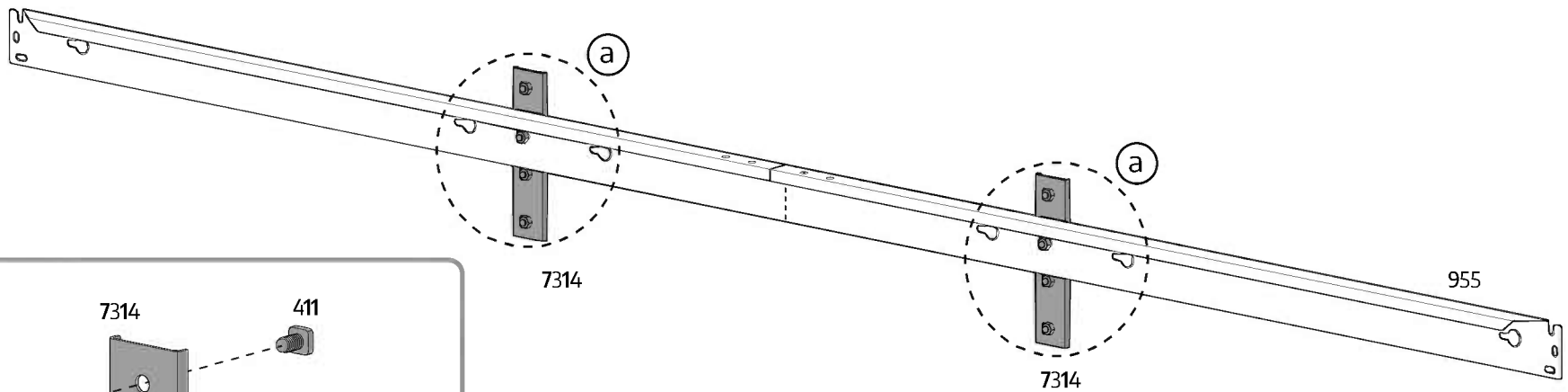
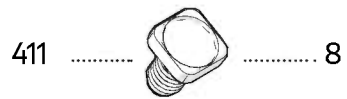
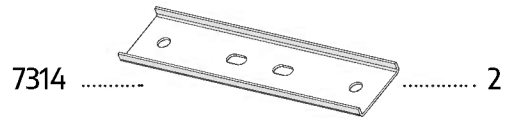
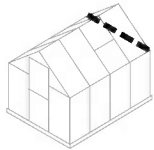

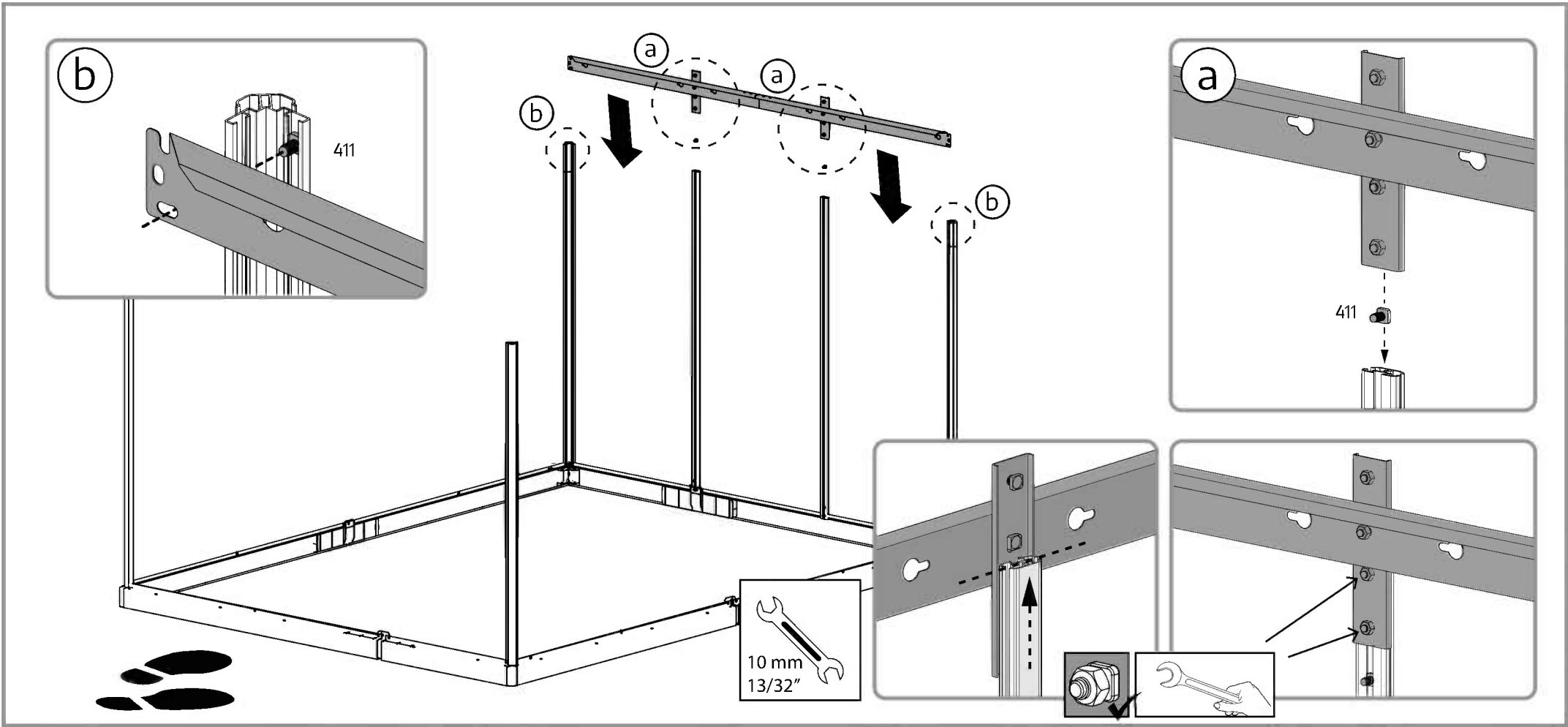
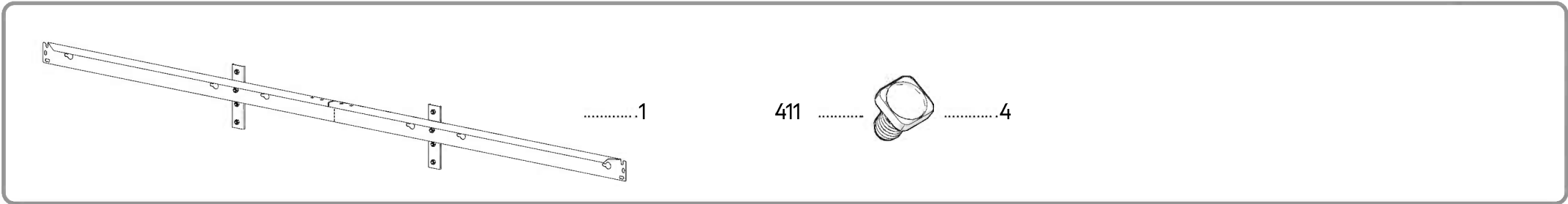
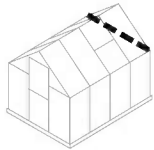



10



The oval hole in the crossbars. #256 should always be assembled to the base of the greenhouse.

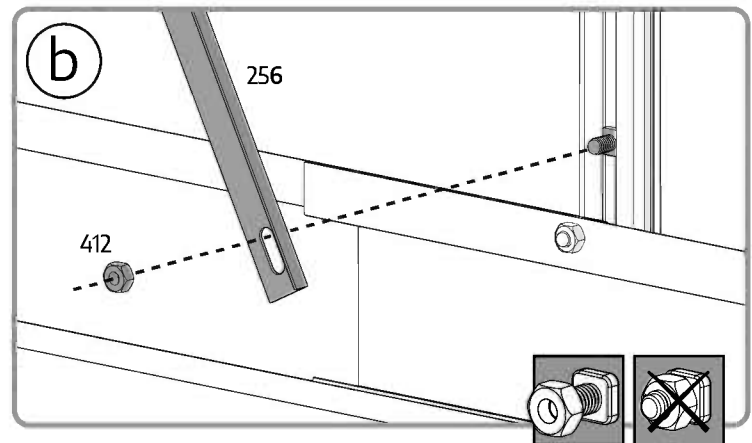
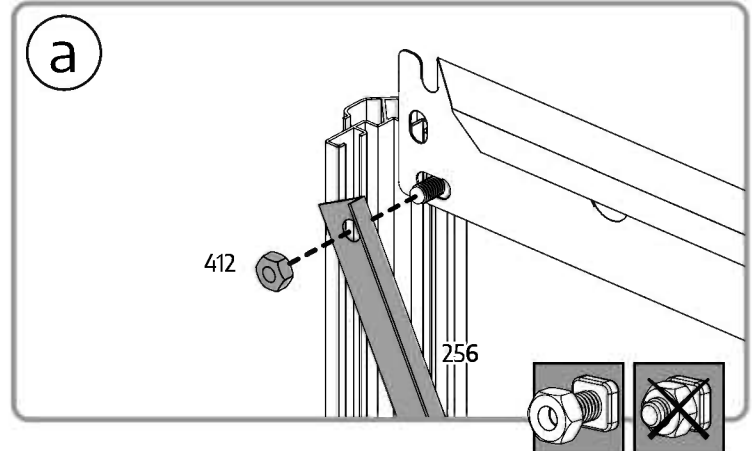
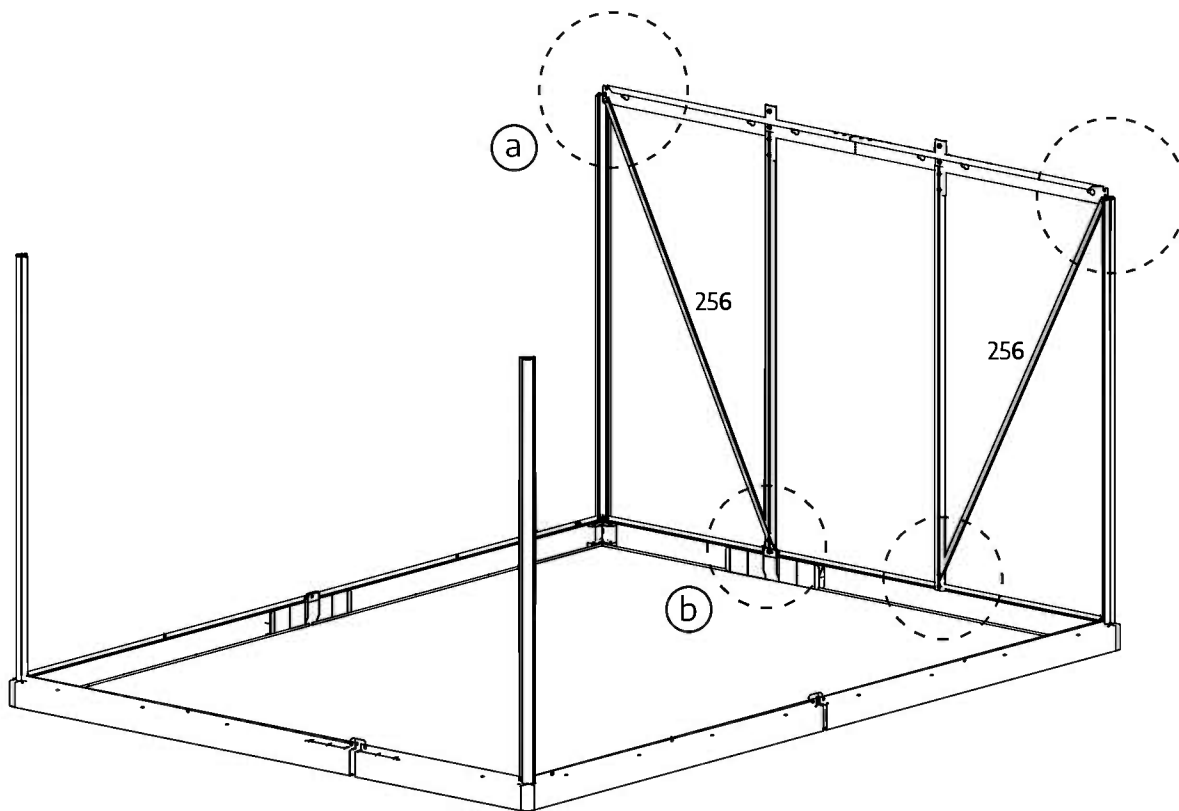
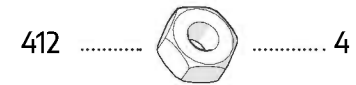
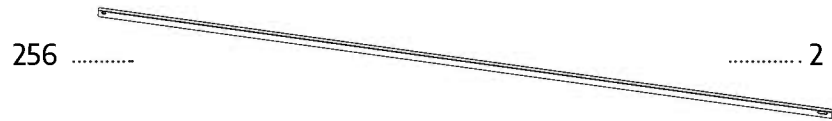
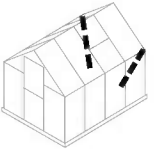

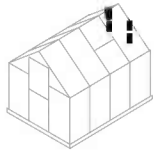

7312 .....  ..... 1

7313 .....  ..... 1

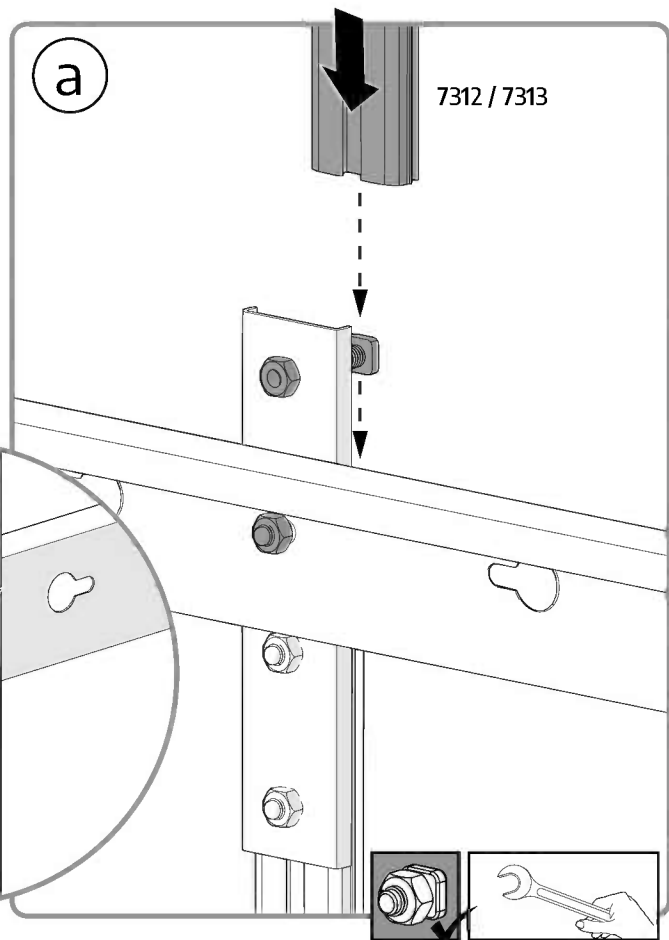
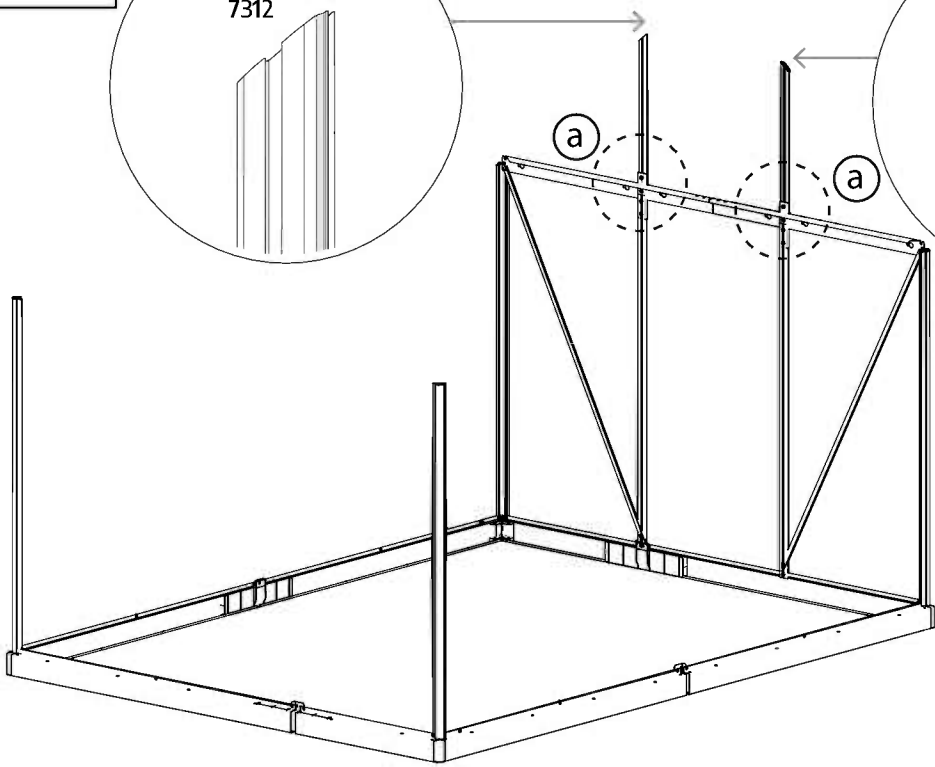
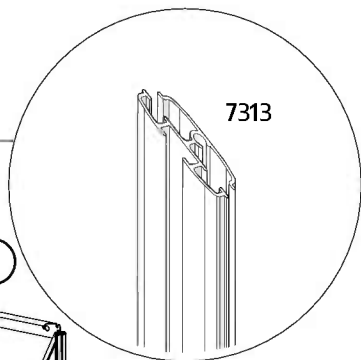
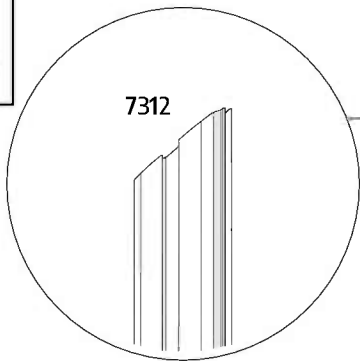



In order to insert profile #8378 in between two #7311 profiles, please apply silicone lubricant spray.

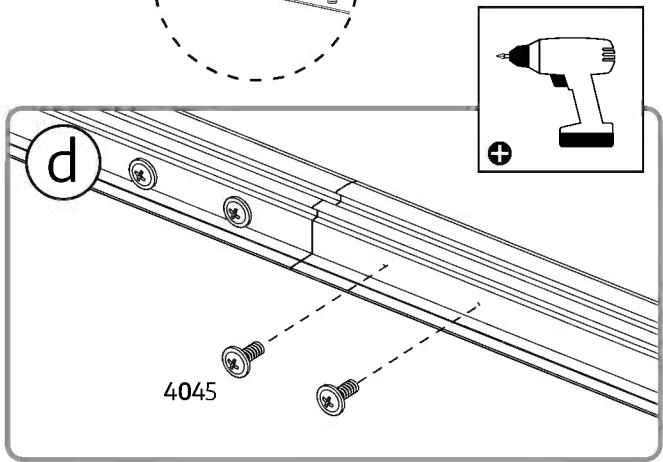
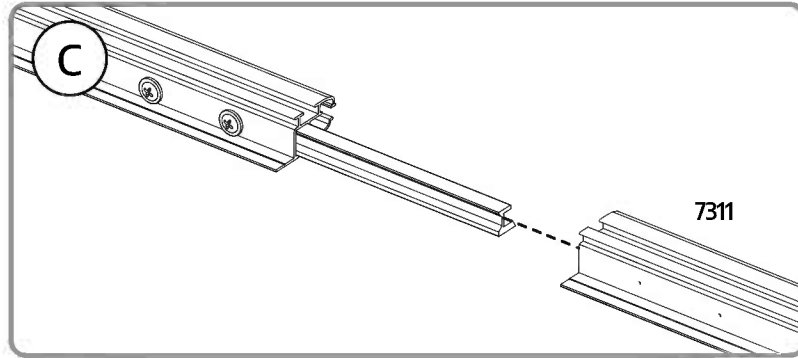
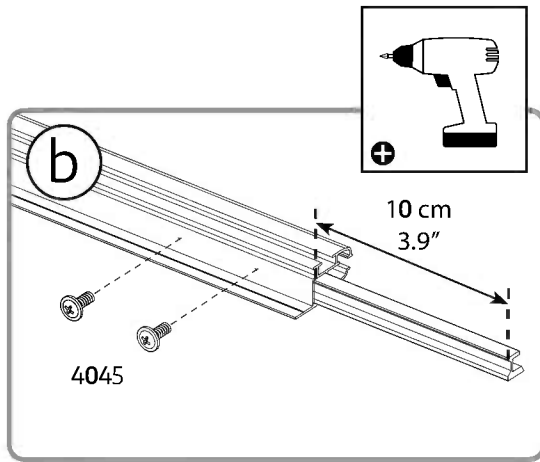
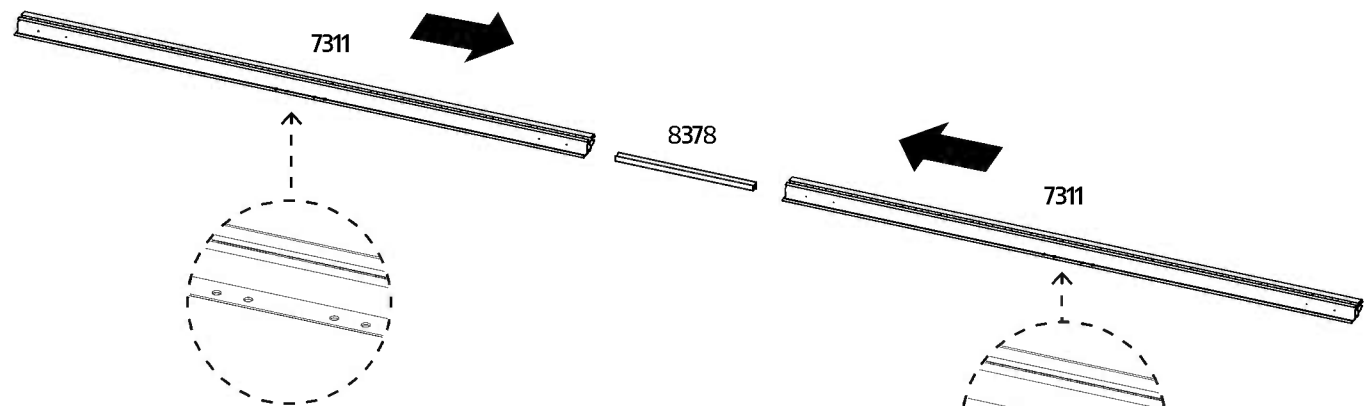
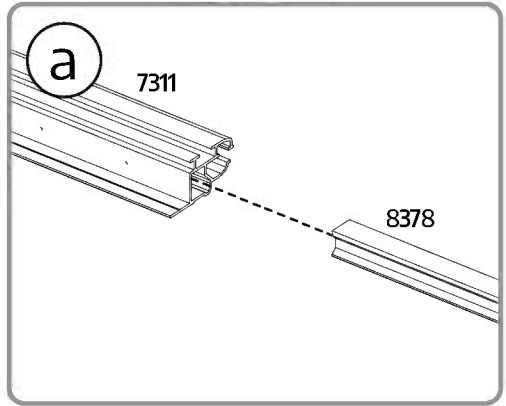
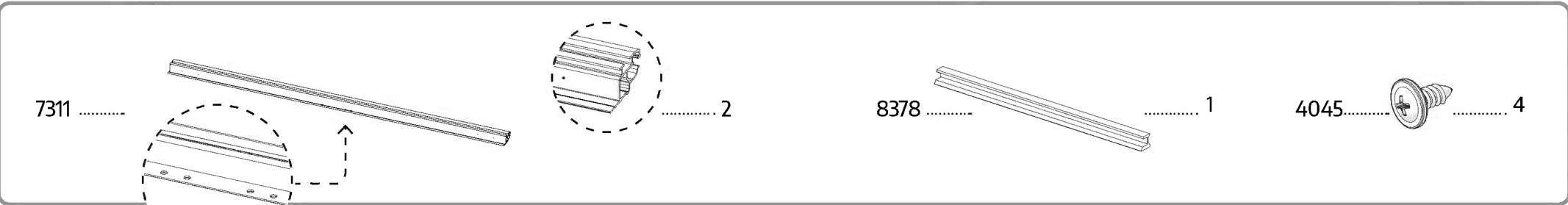
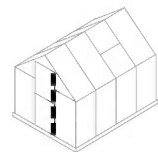



In order to insert profile #8378 in between two #7310 profiles, please apply silicone lubricant spray.

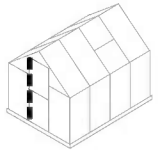

7310 .....

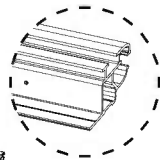
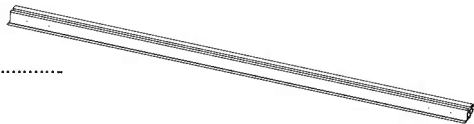

..... 2

8378 .....

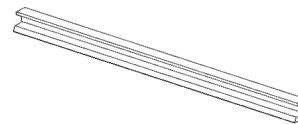

..... 1

4045.....



..... 4

a

7310

8378

7310

8378

7310

b

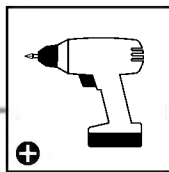
10 cm  
3.9"

4045

c

7310

d

4045



Determines door direction door post #7311 is where door hinges will be located.

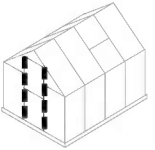

7310 .....  ..... 1

7311 .....  ..... 1

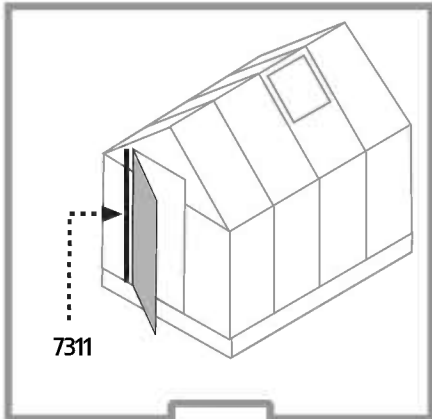

or

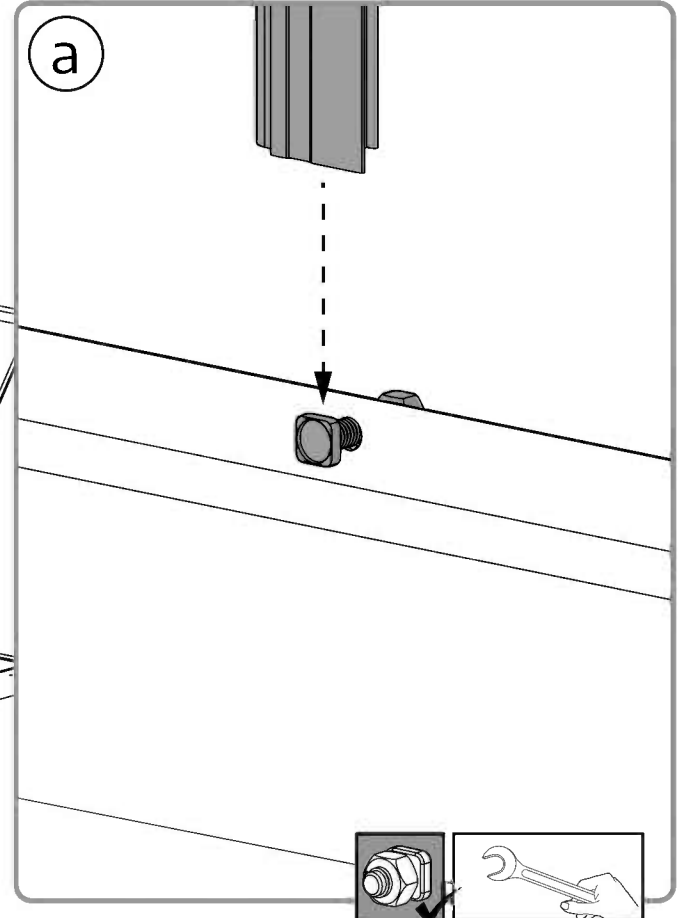
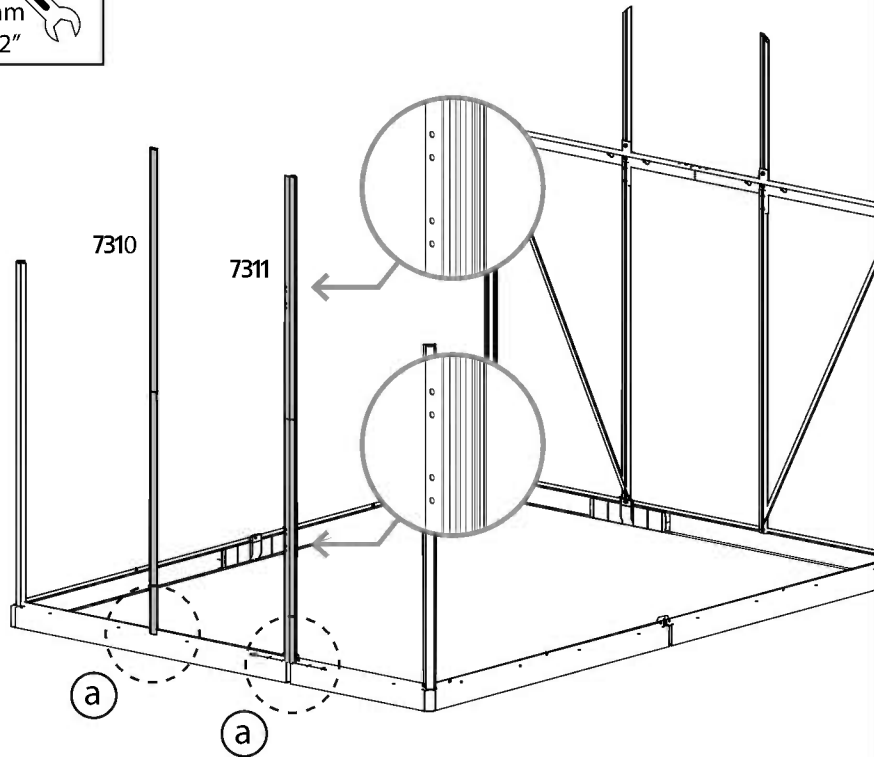
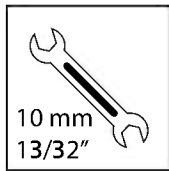
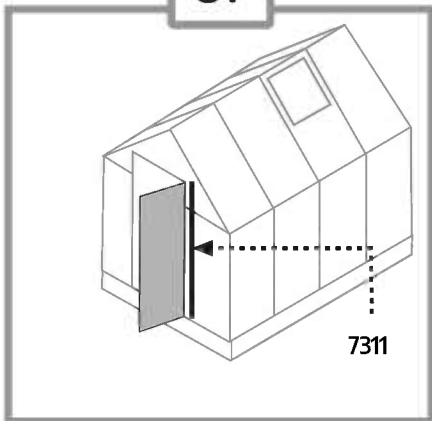

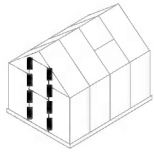

411 .....  ..... 6

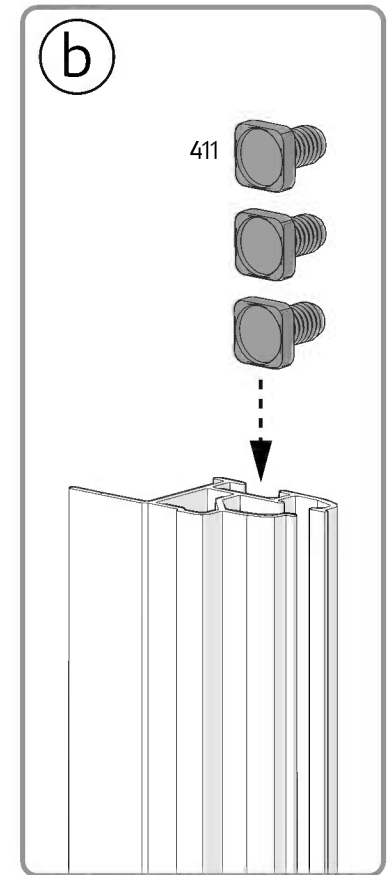
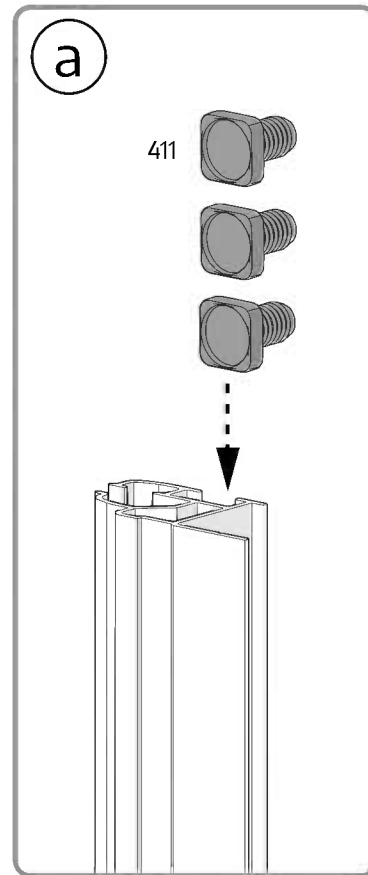
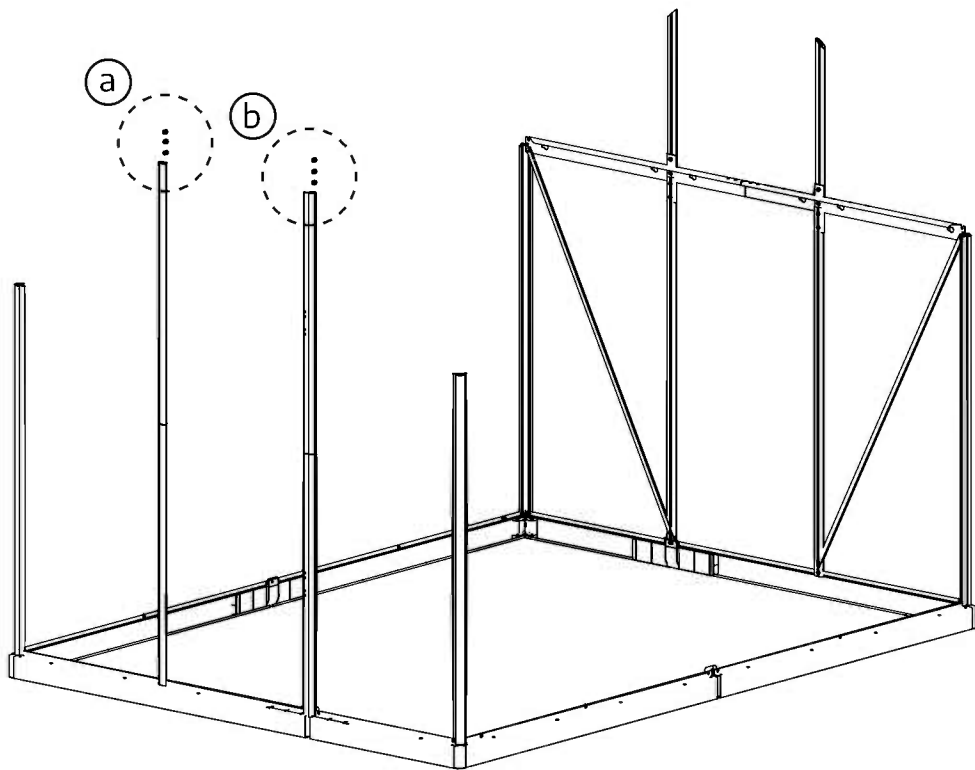



The oval hole in the crossbars. #256 should always be assembled to the base of the greenhouse.

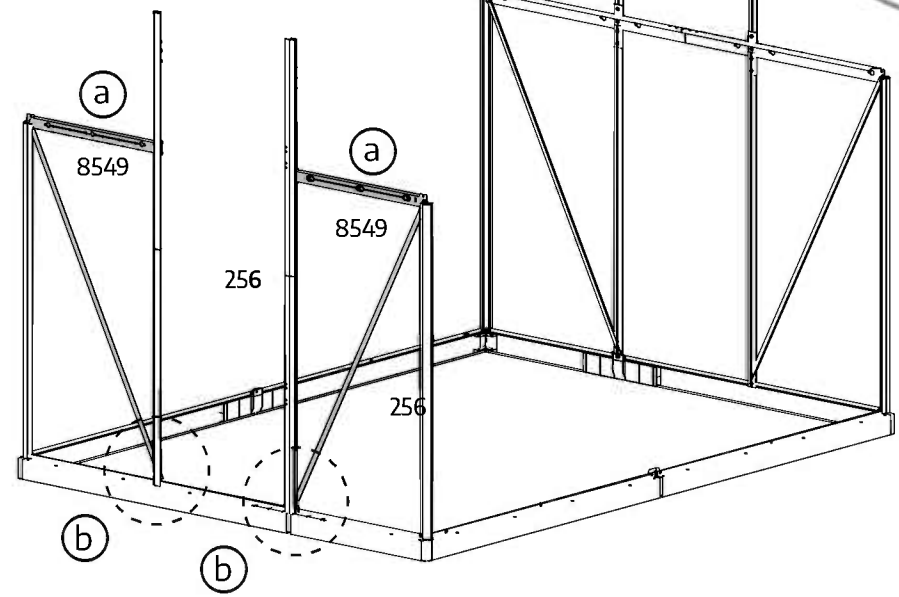
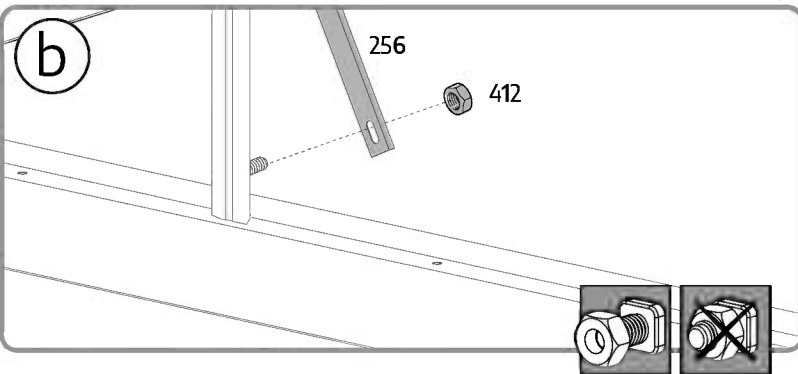
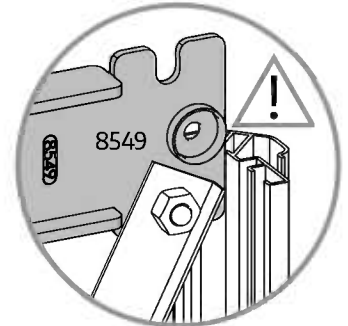
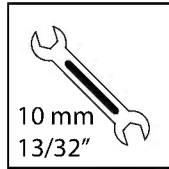
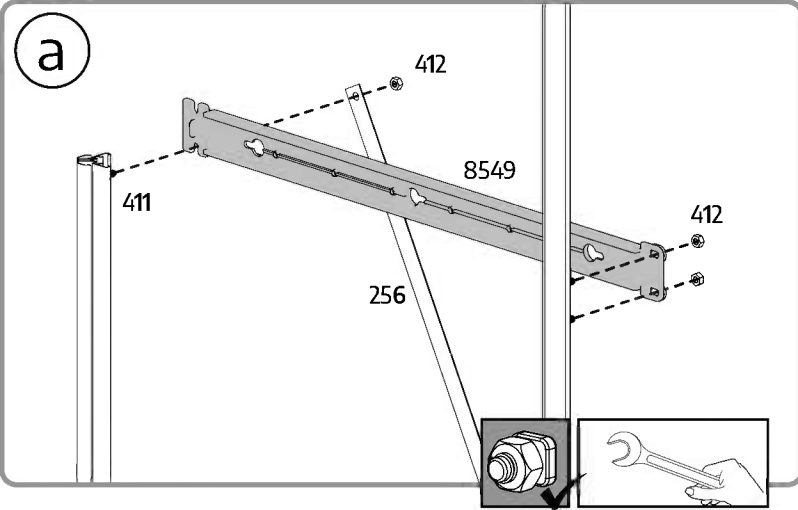
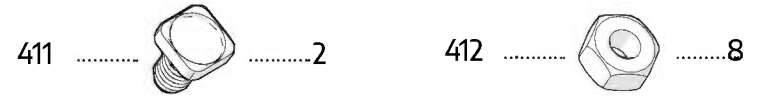
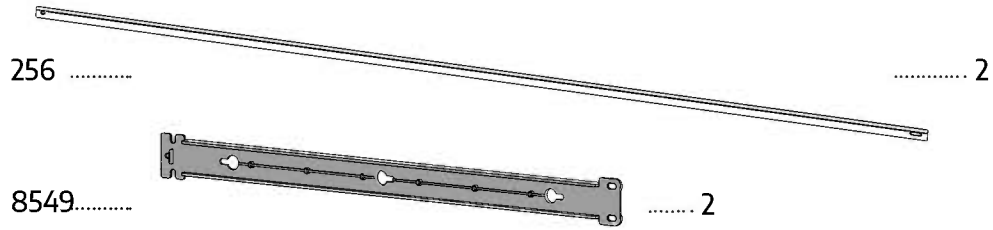
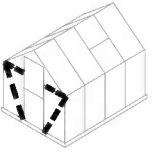

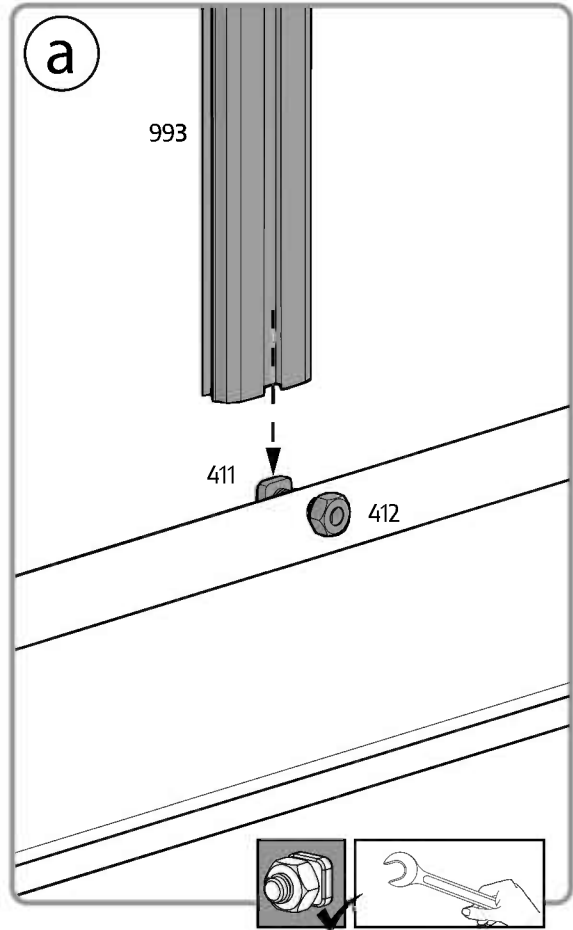
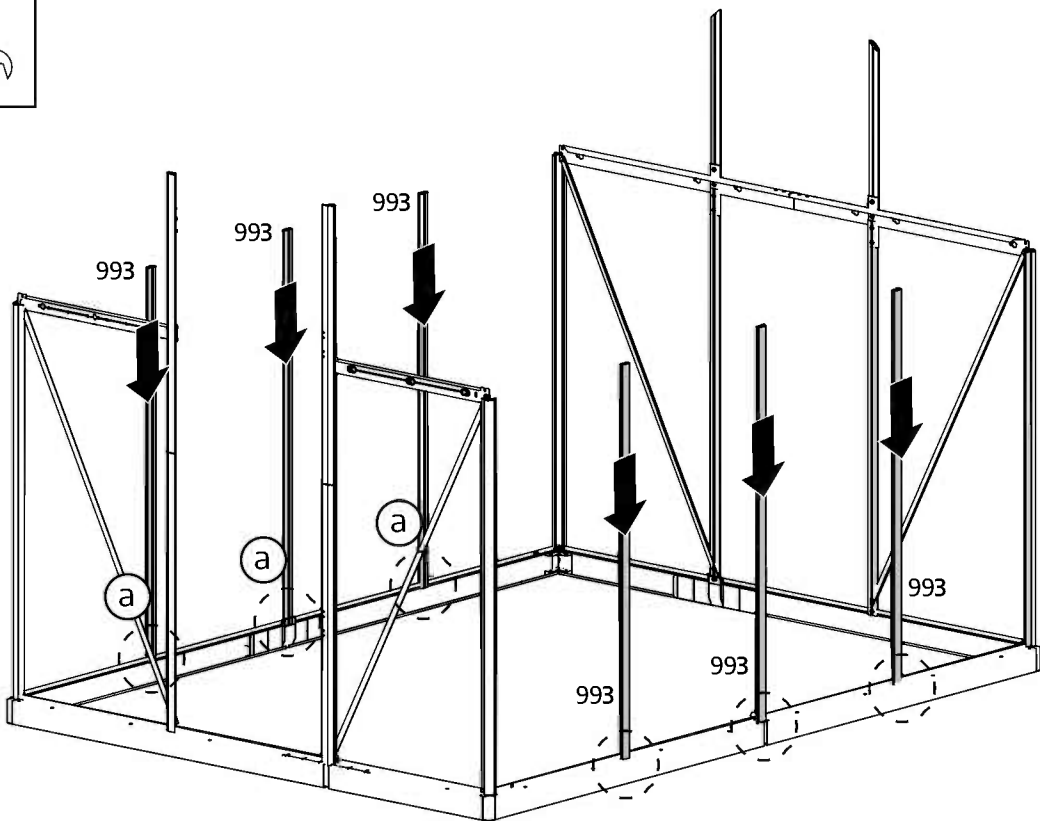
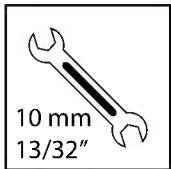
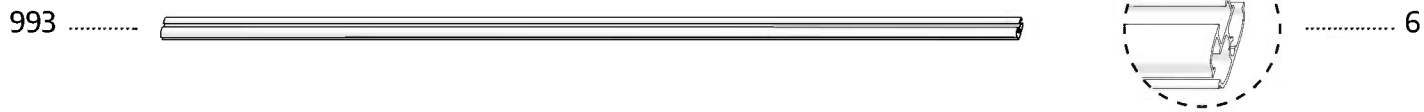
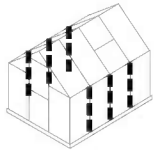



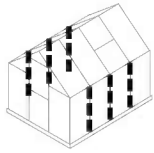

411 ..... 4

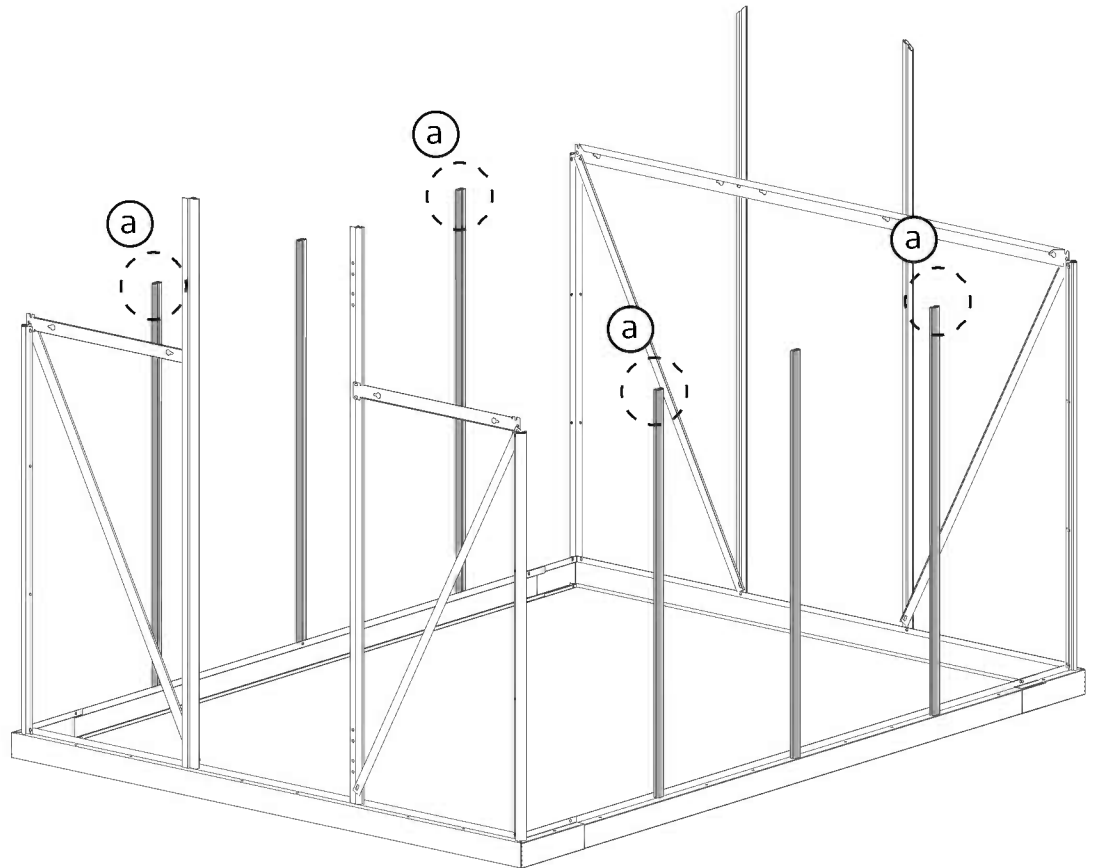
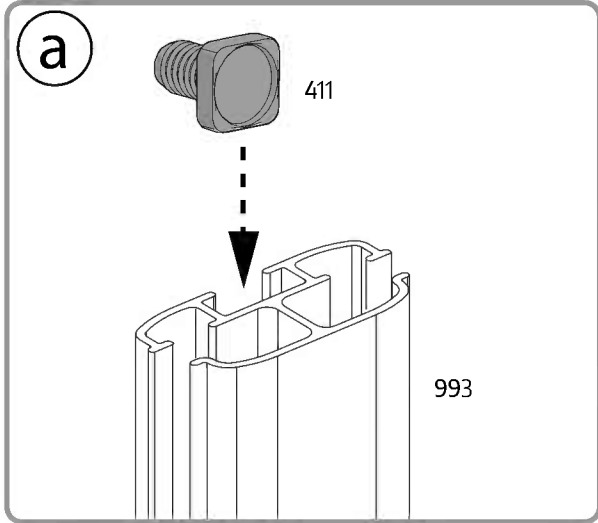



The oval hole in the crossbars. #256 should always be assembled to the base of the greenhouse.

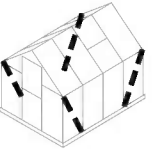

256 ..... 4

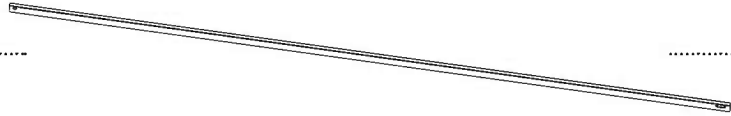

411 ..... 4



412 ..... 8

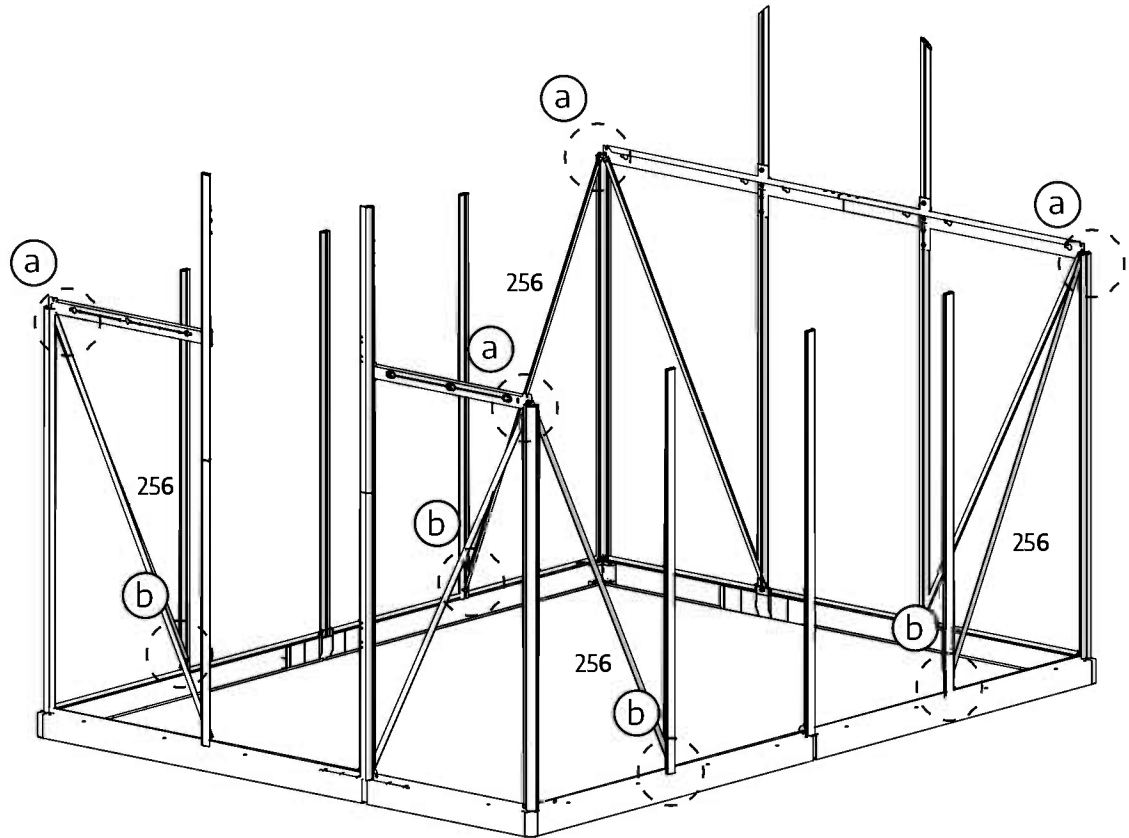
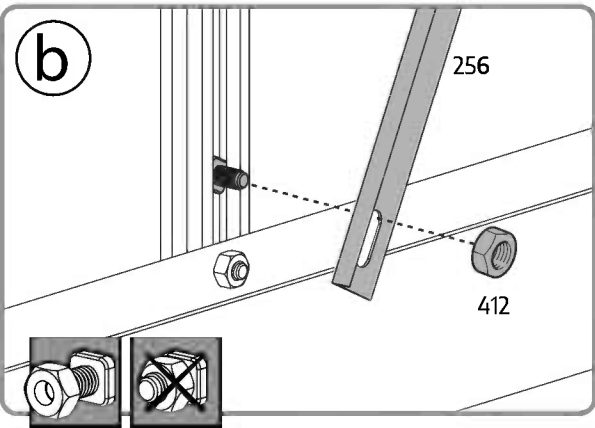
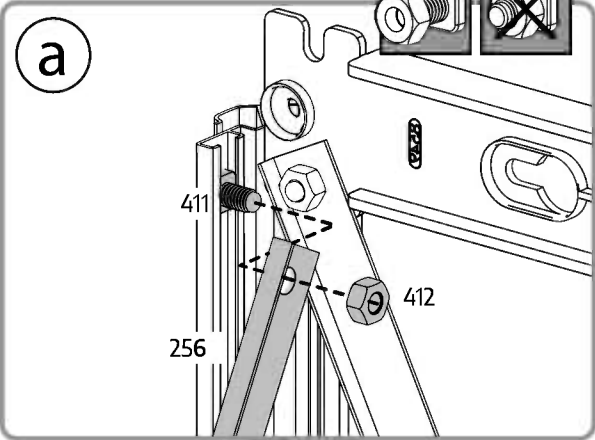
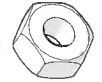

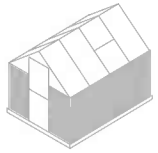

7011 .....

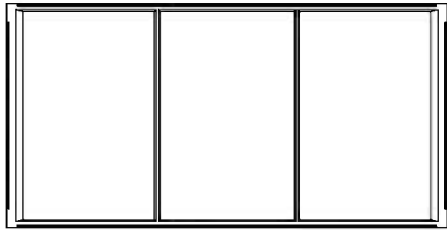

..... 13

a

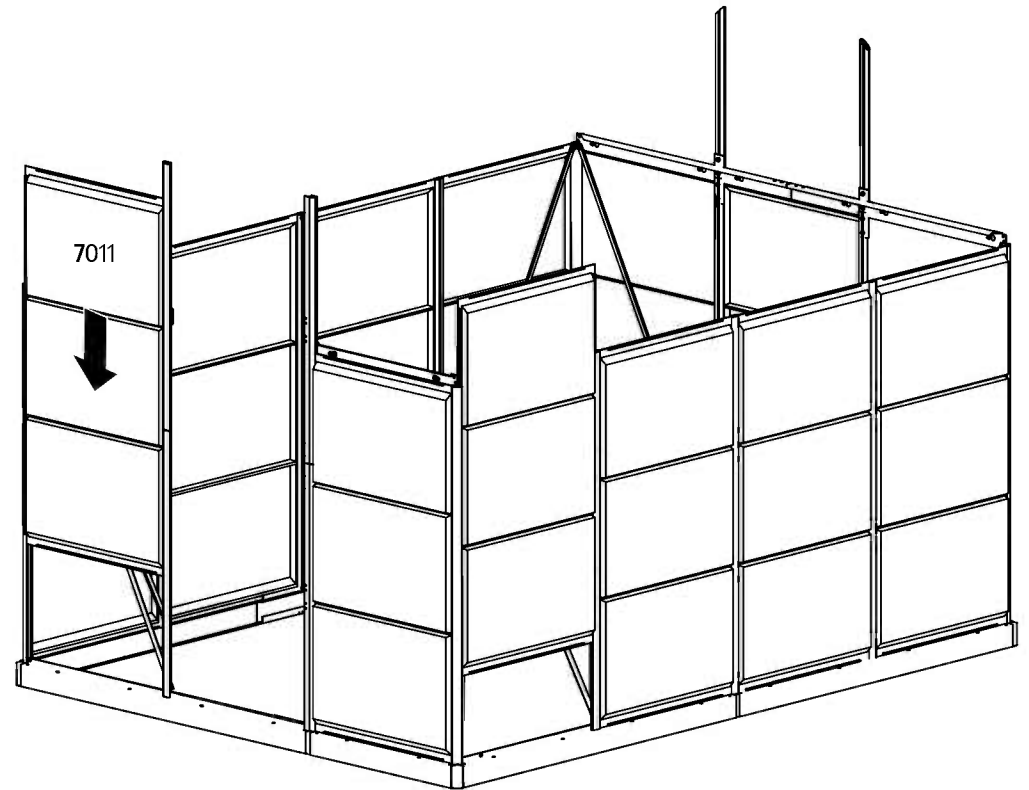
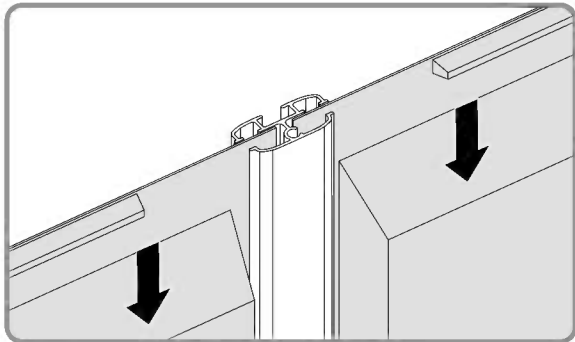
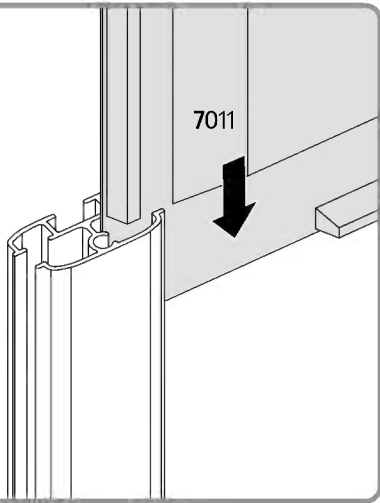

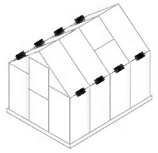

318 ..... 8

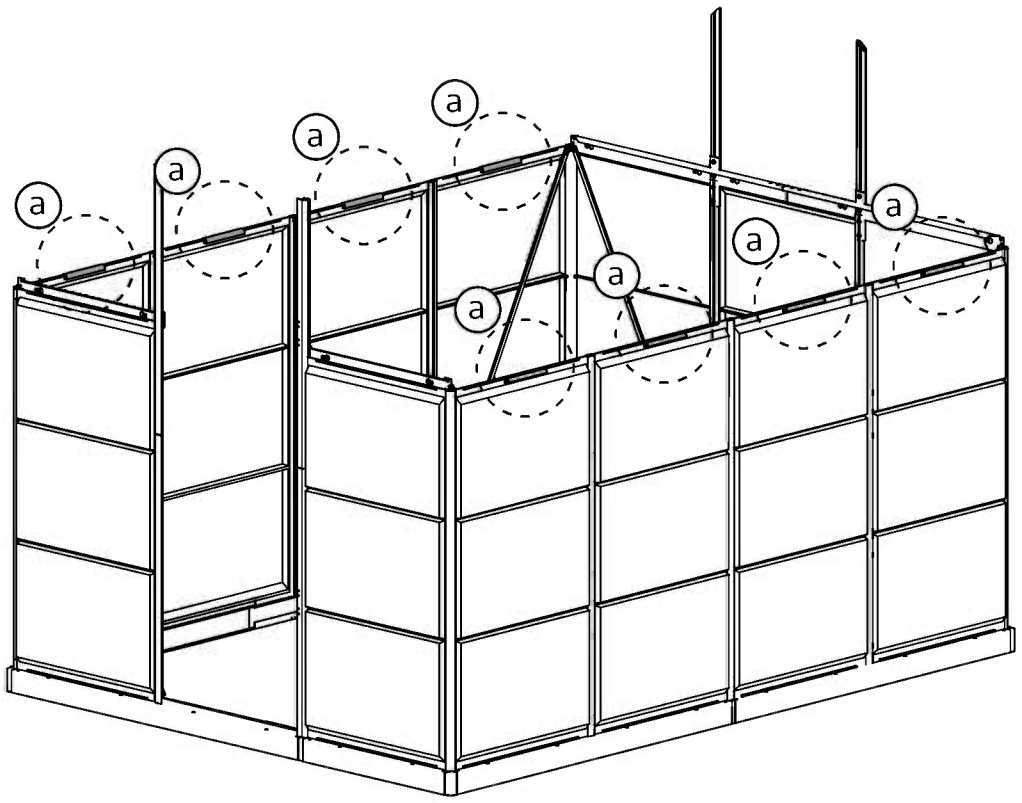
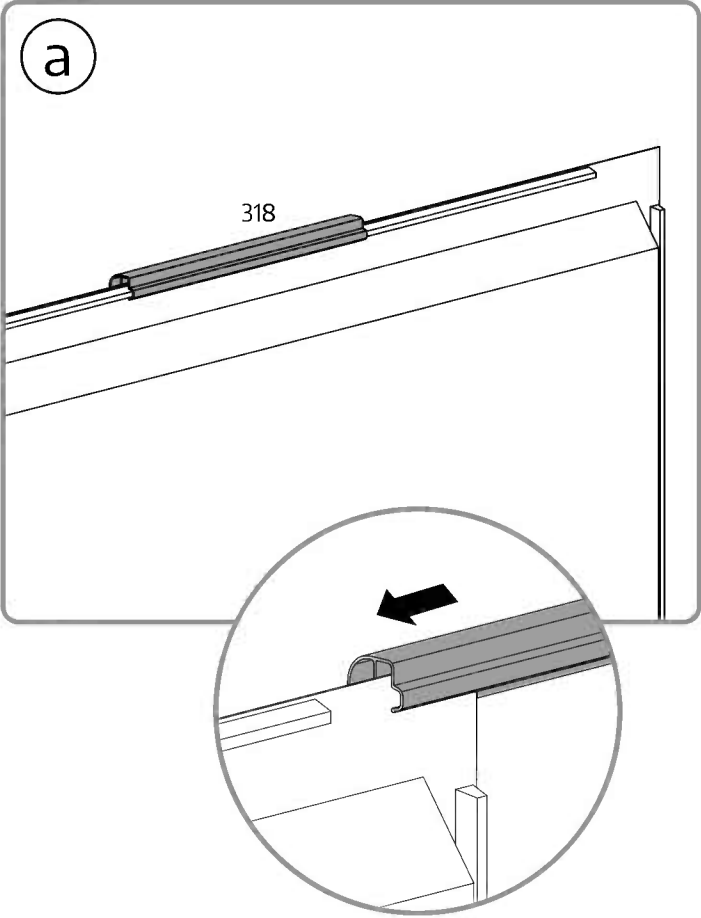
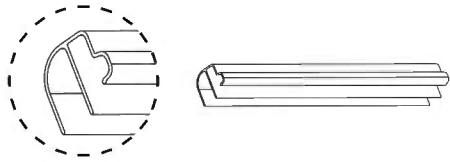

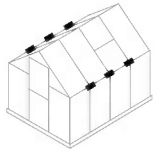

411 .....  .....6

412 .....  .....6

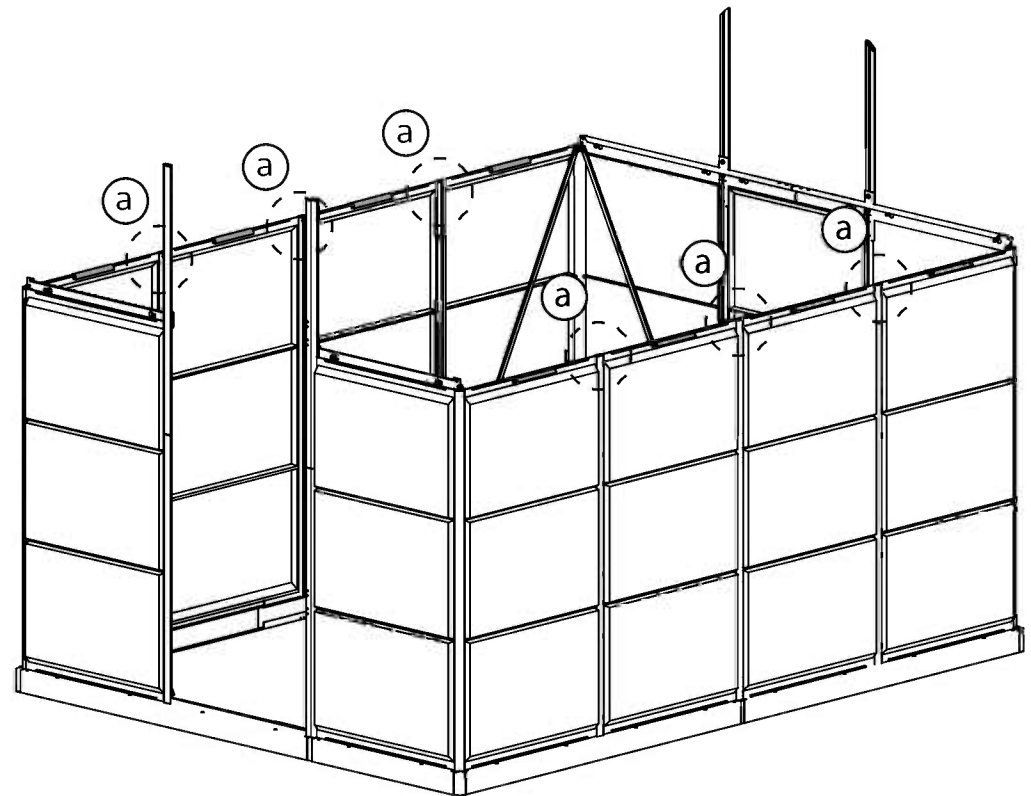
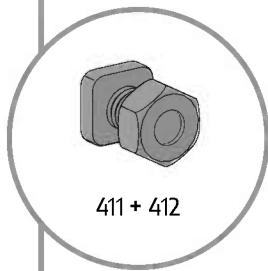
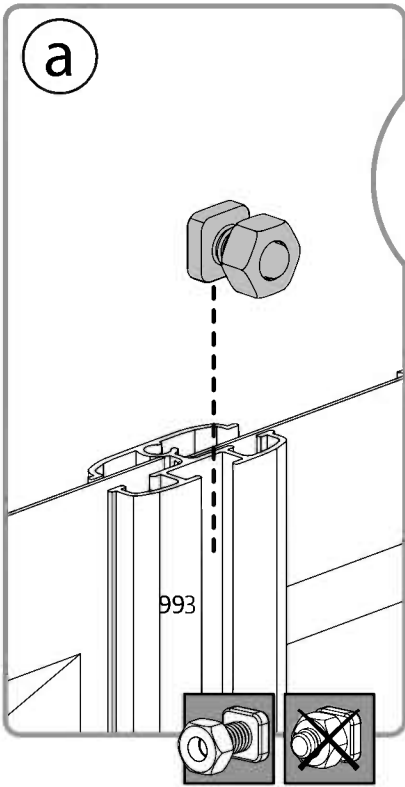

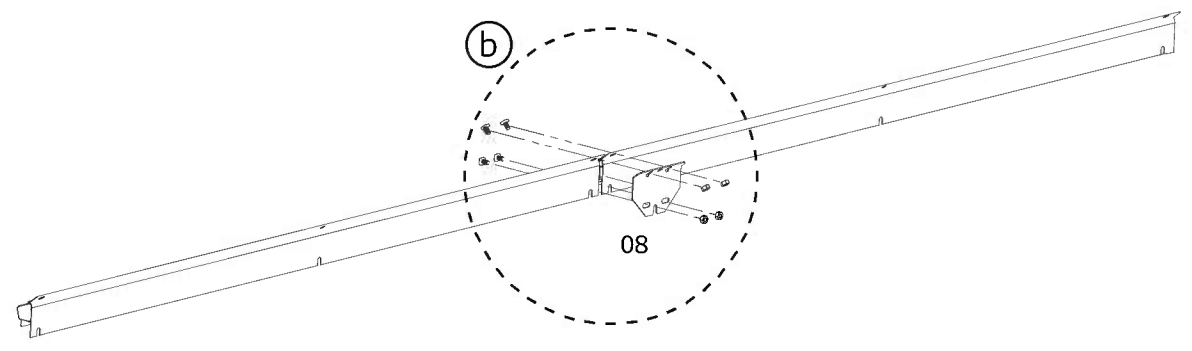
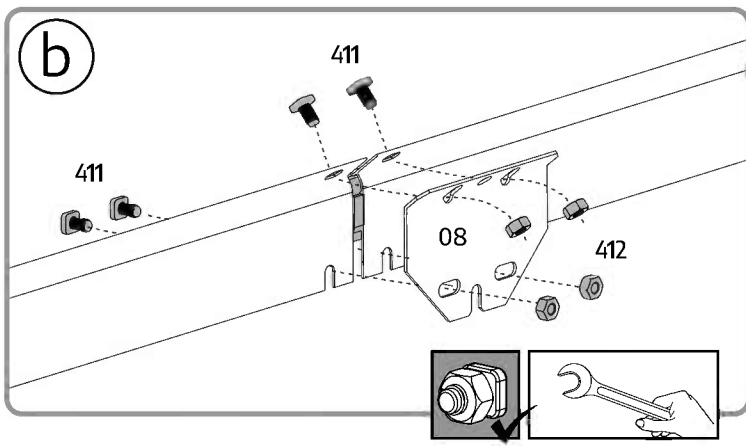
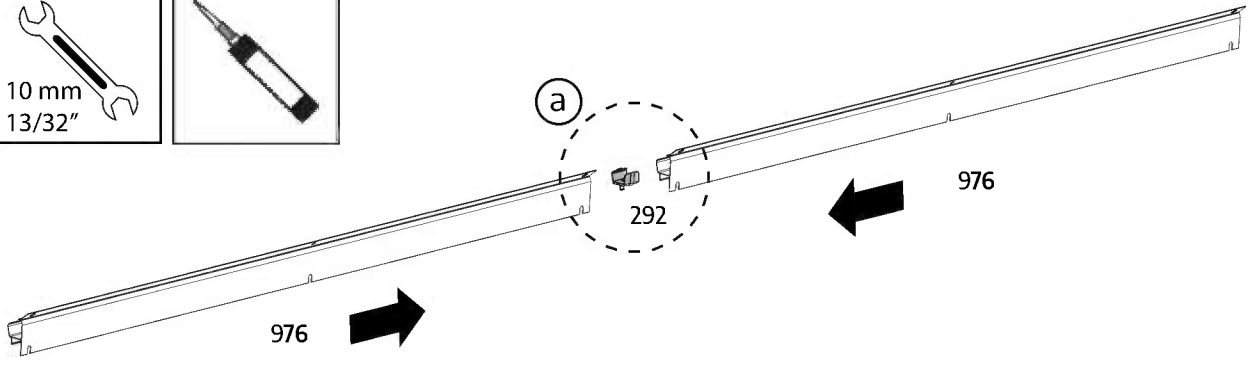
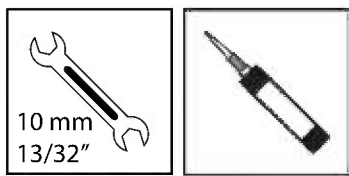
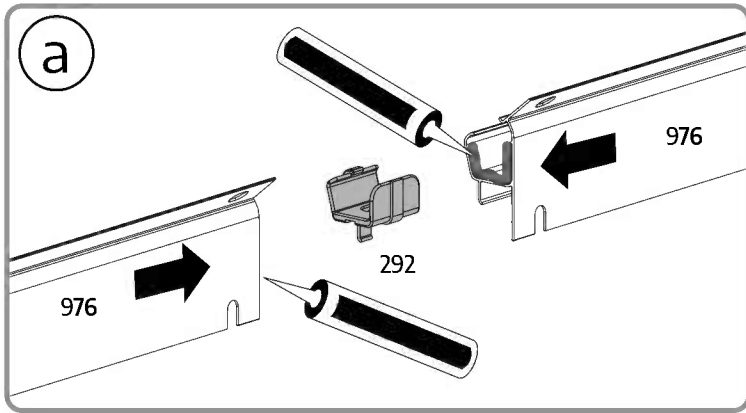
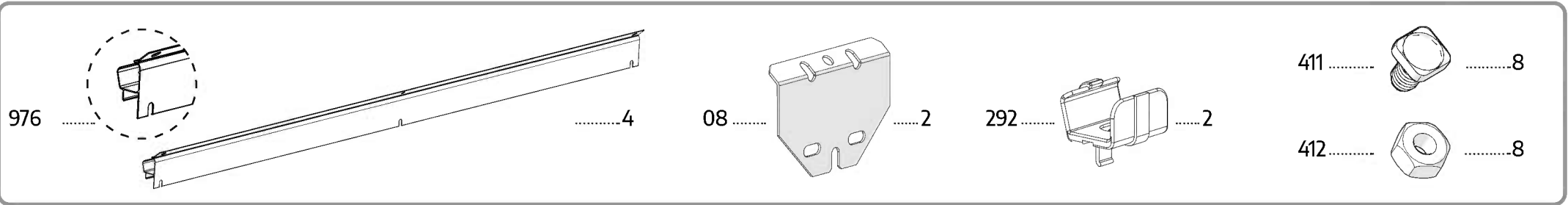

x2

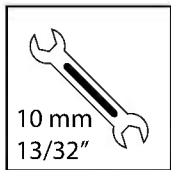
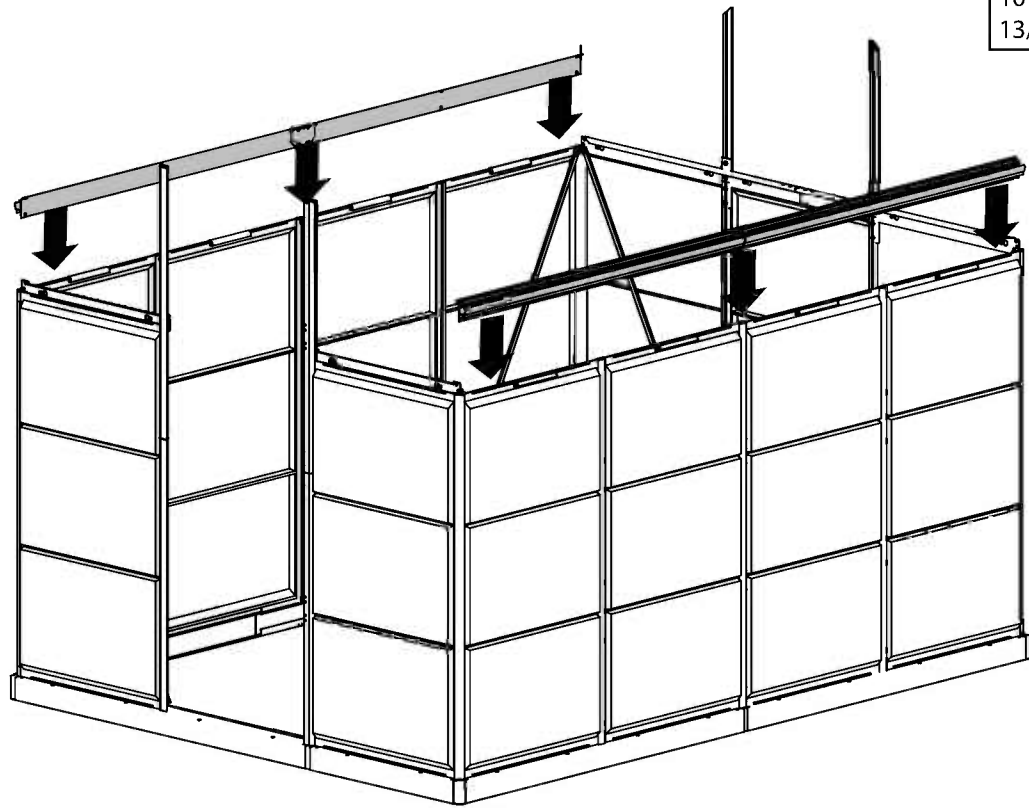
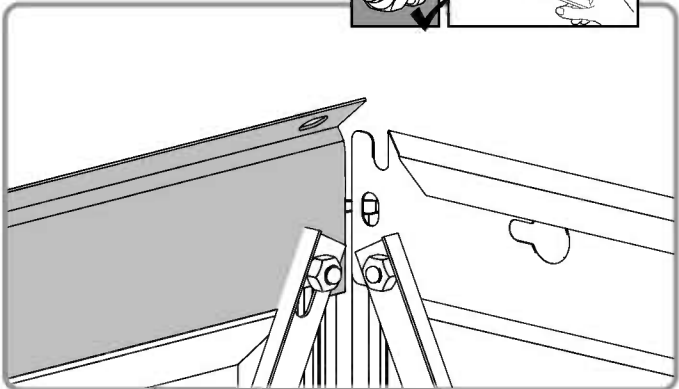
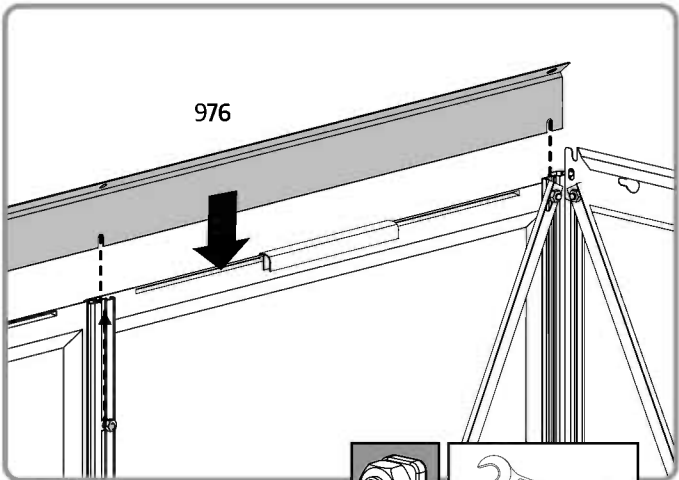
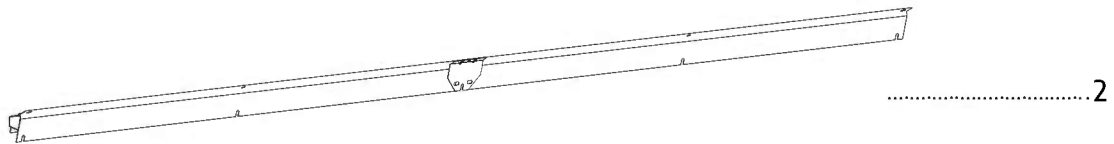
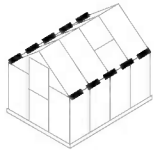

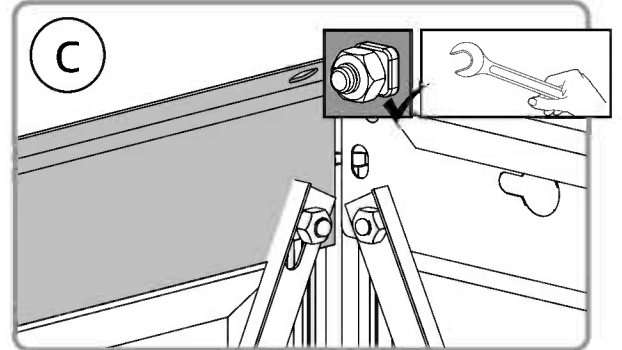
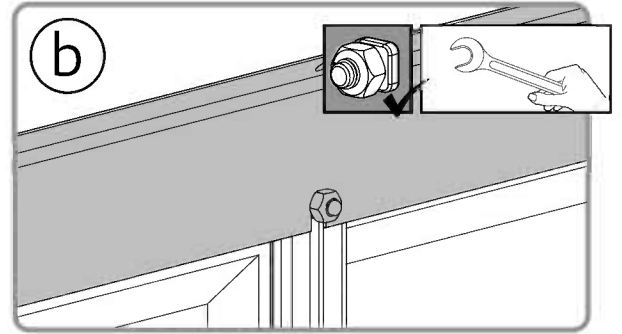
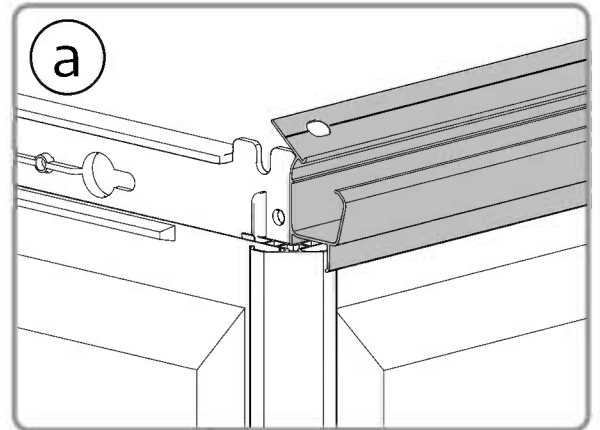
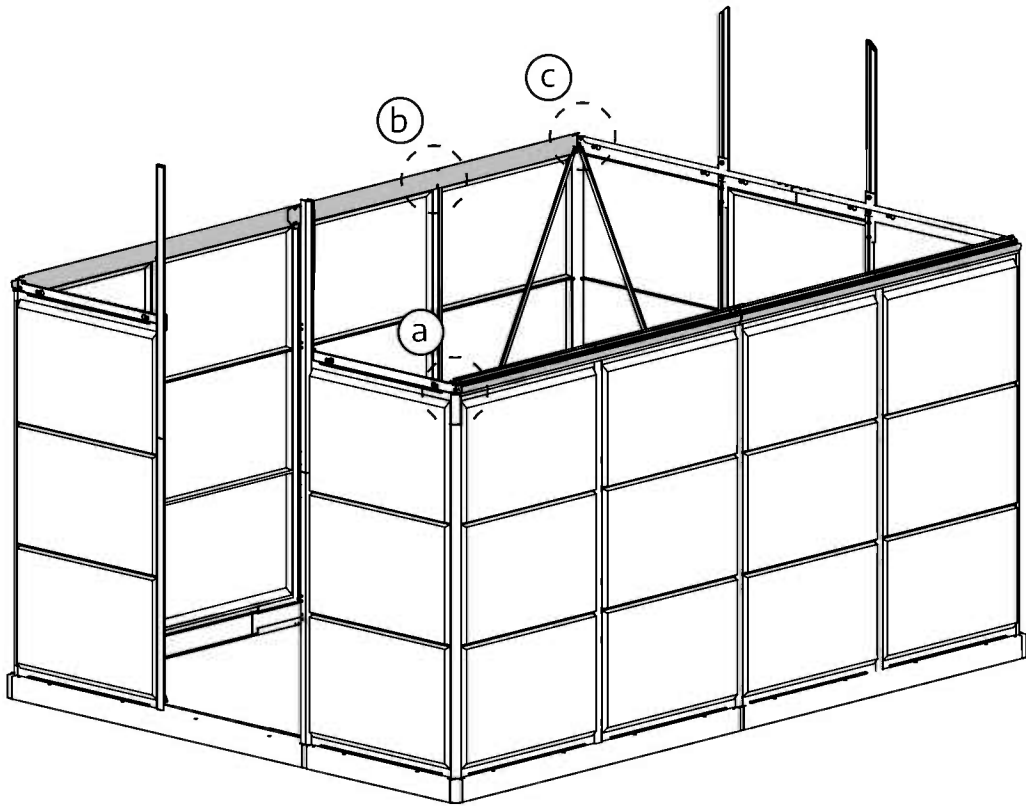



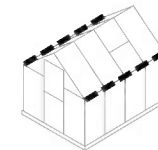

4008 ..... 2

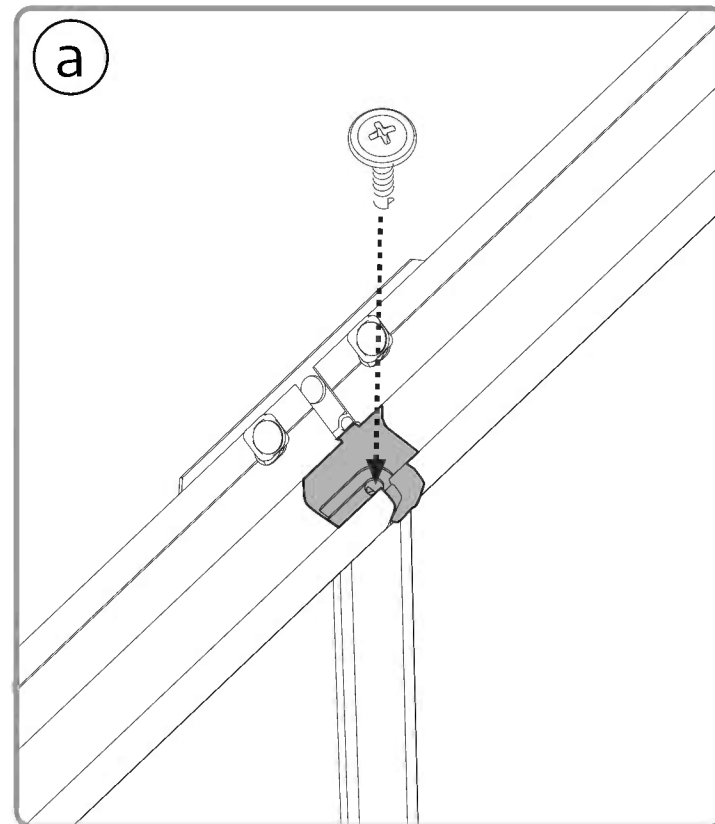
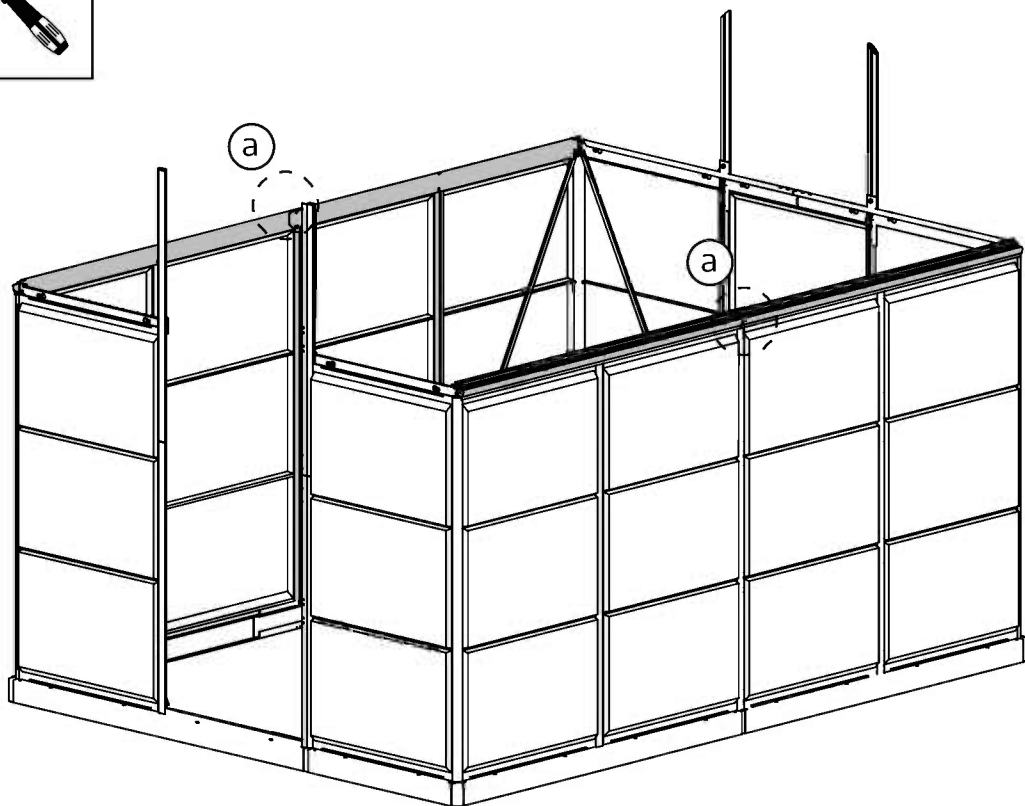
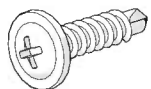

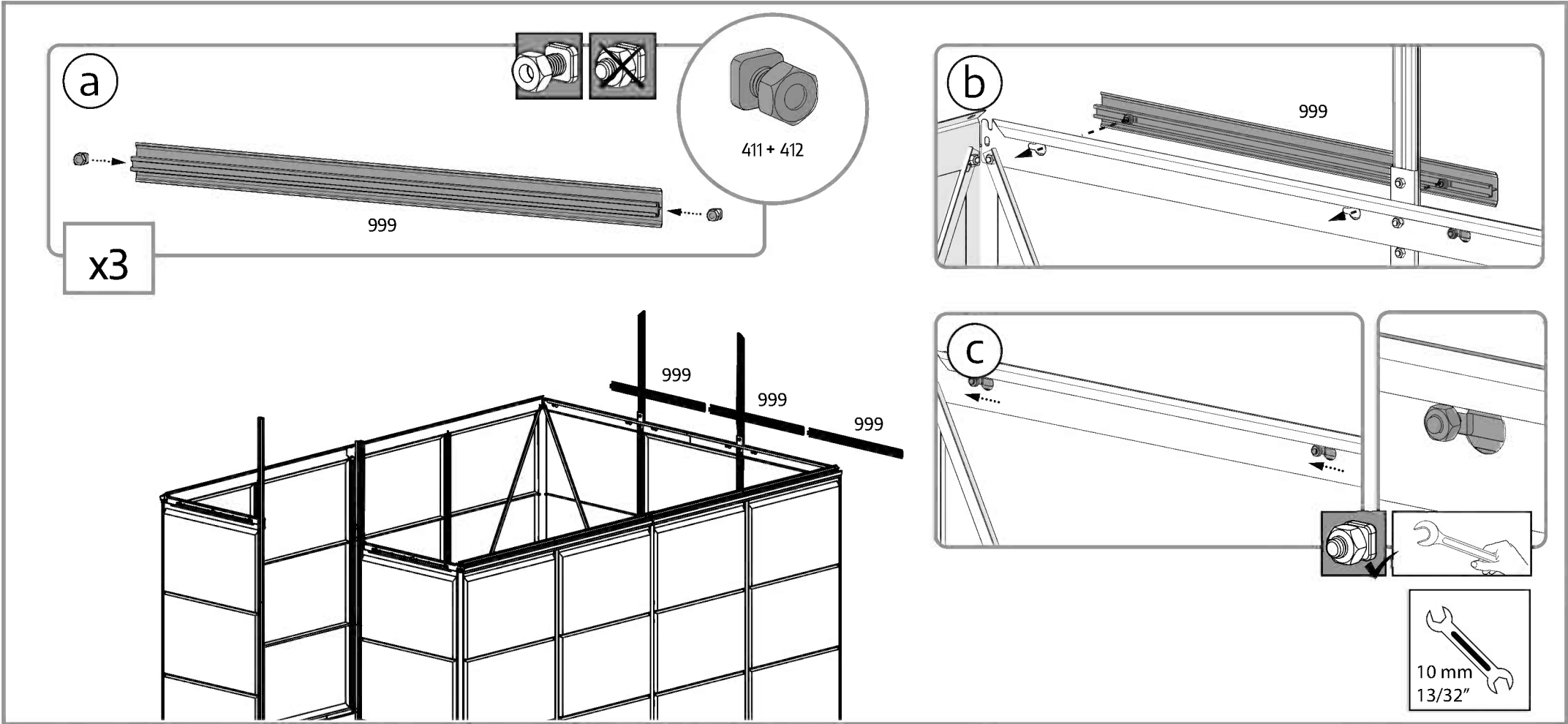



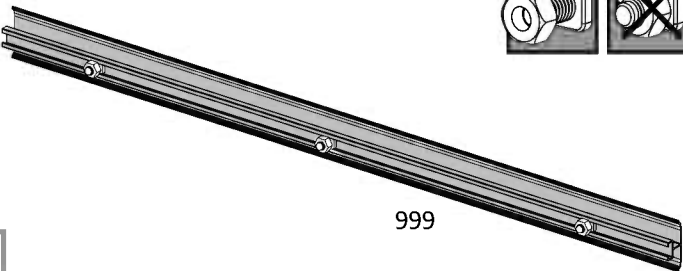

999 .....  ..... 2 

411 .....  ..... 6      412 .....  ..... 6

**a**  ..... 999

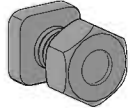

 ..... 411 + 412

**x2**

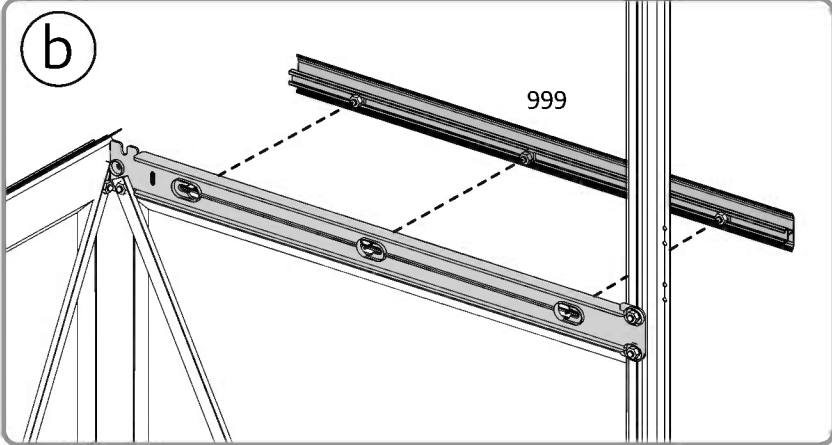
**b** 

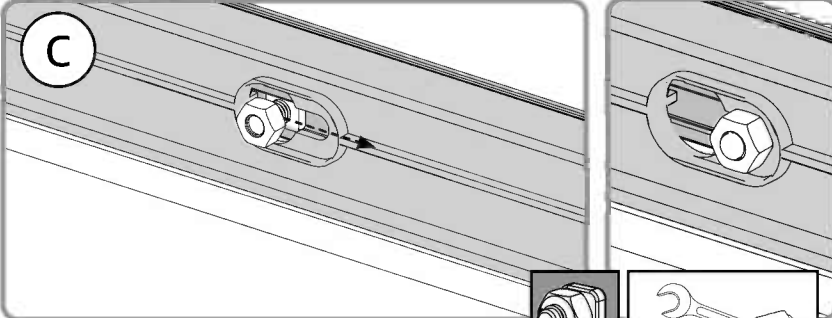
**c** 

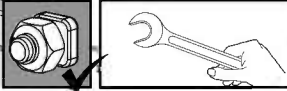

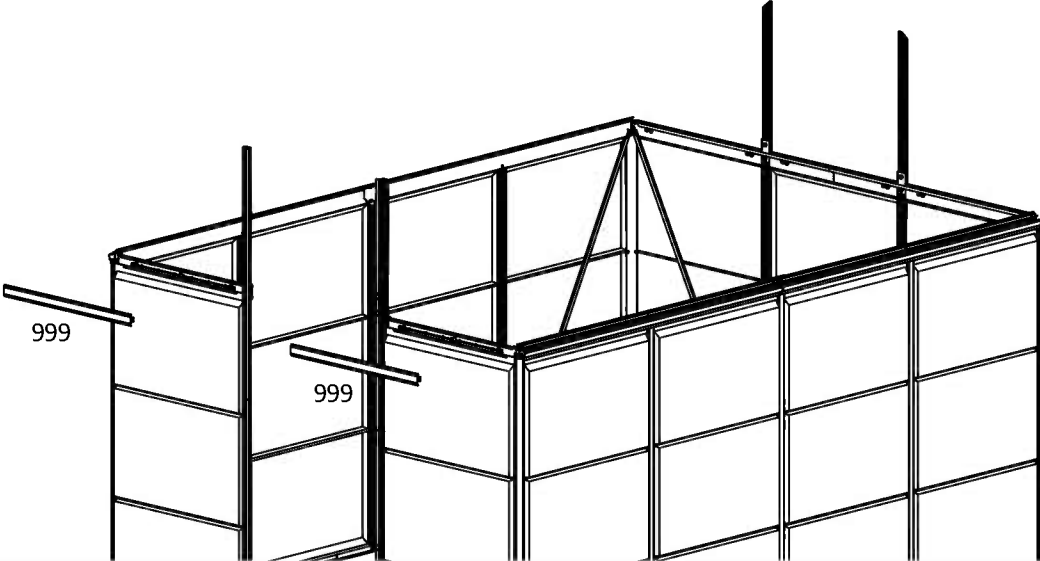



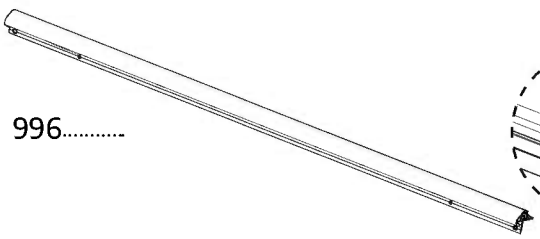
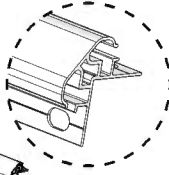

996.....  .....2 

570 .....  ..... 1

411 .....  .....2

412 .....  .....2

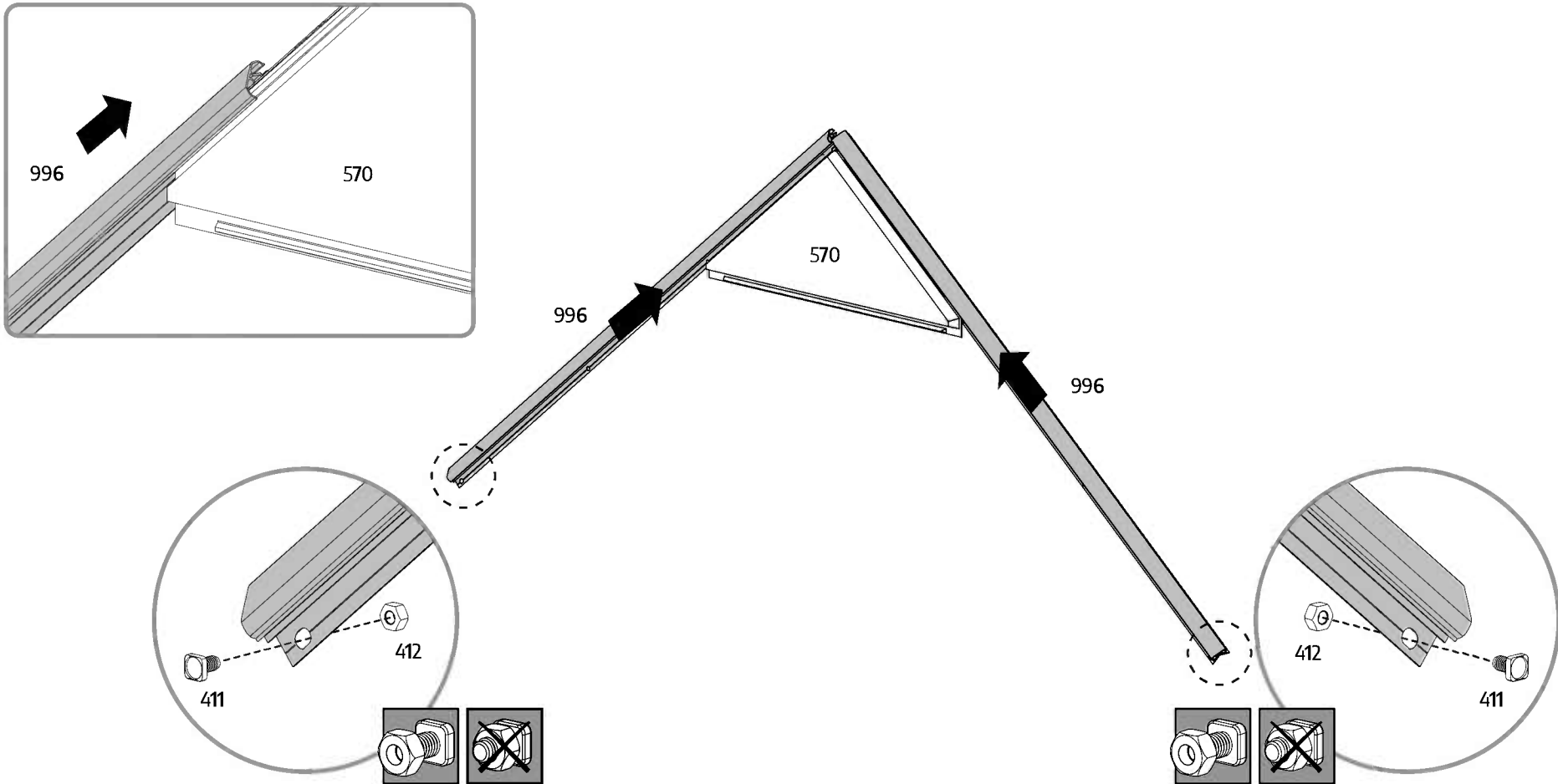

996

570

996

570





996

411

412

411

412



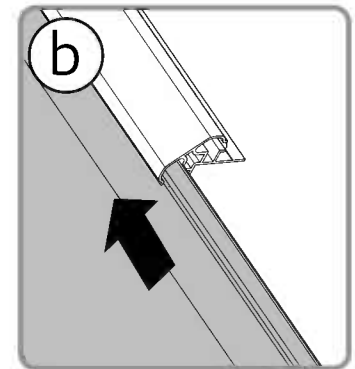
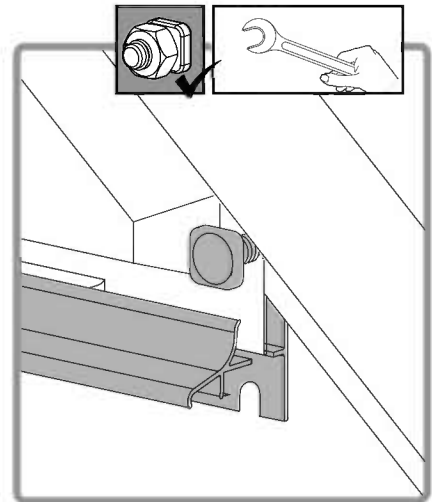
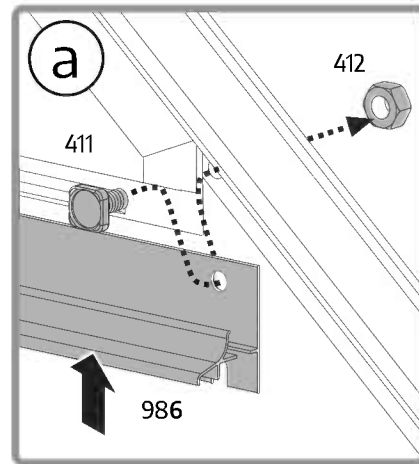
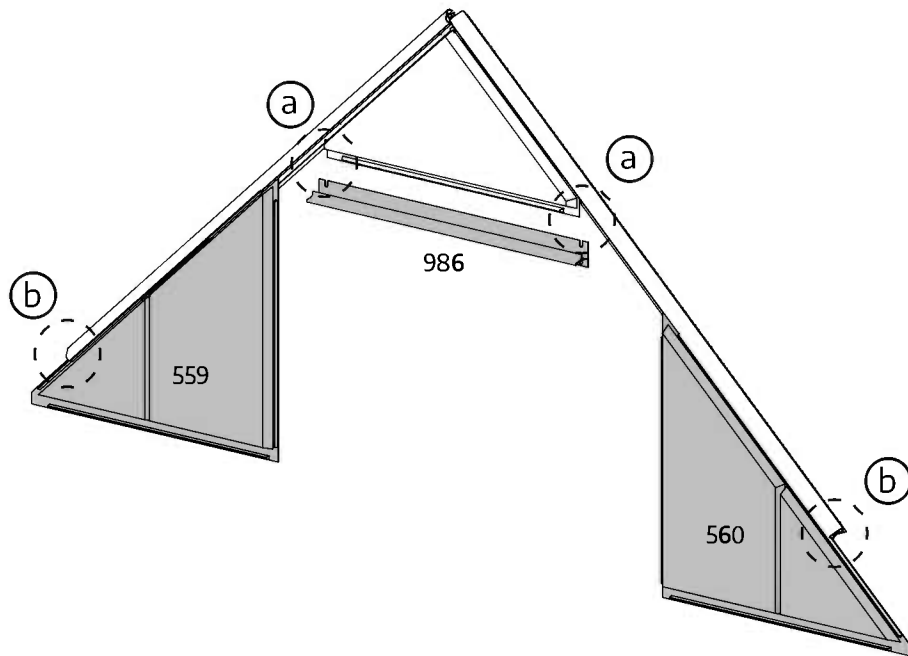
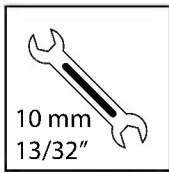
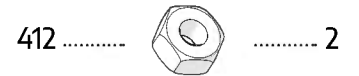
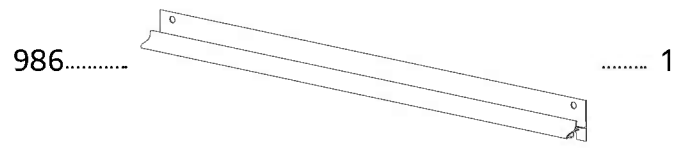
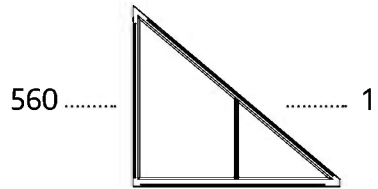
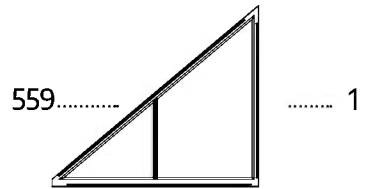



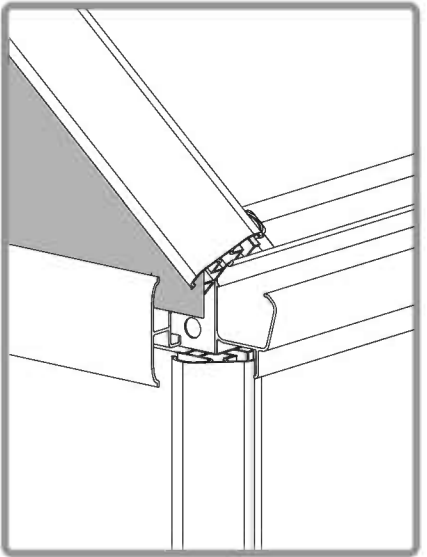
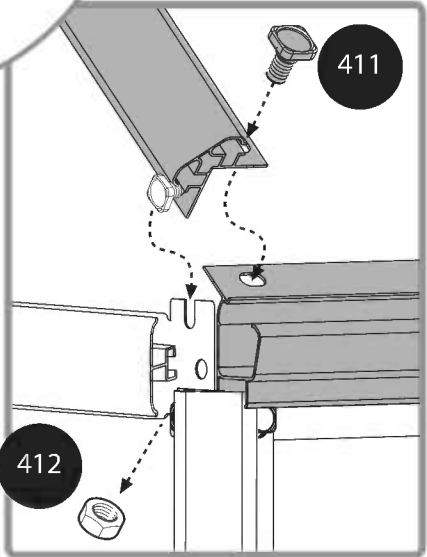
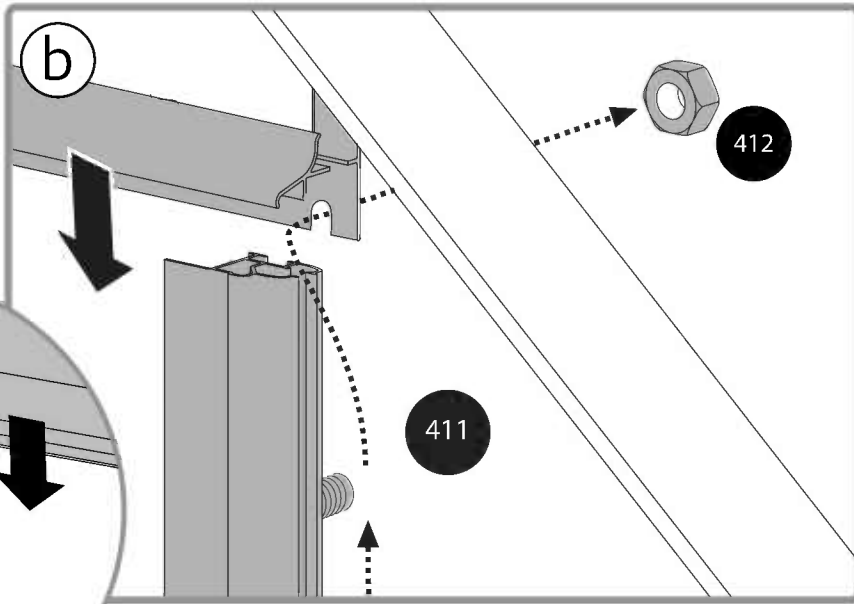
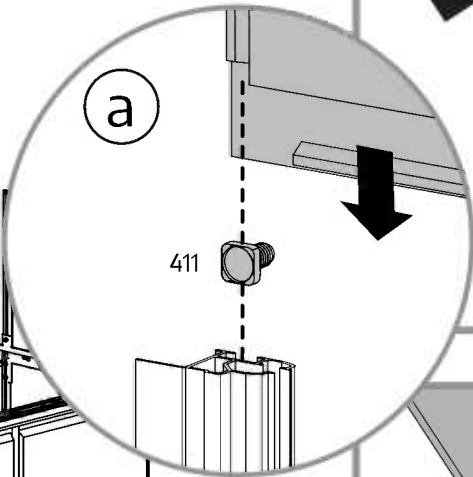
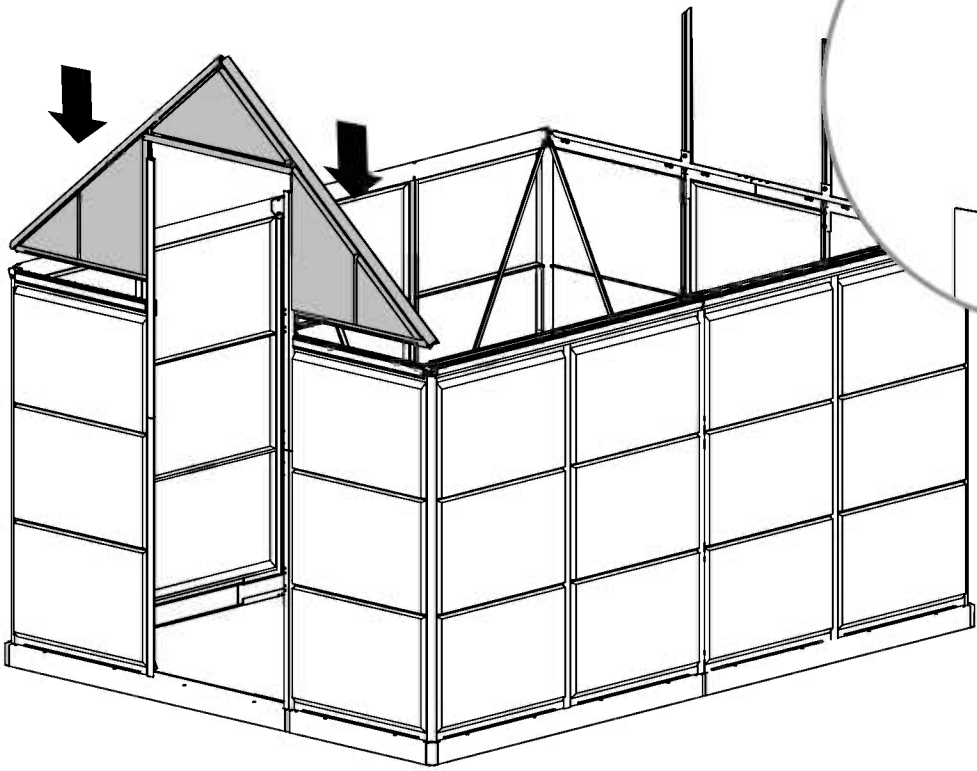

411 .....  ..... 4

412 .....  ..... 4

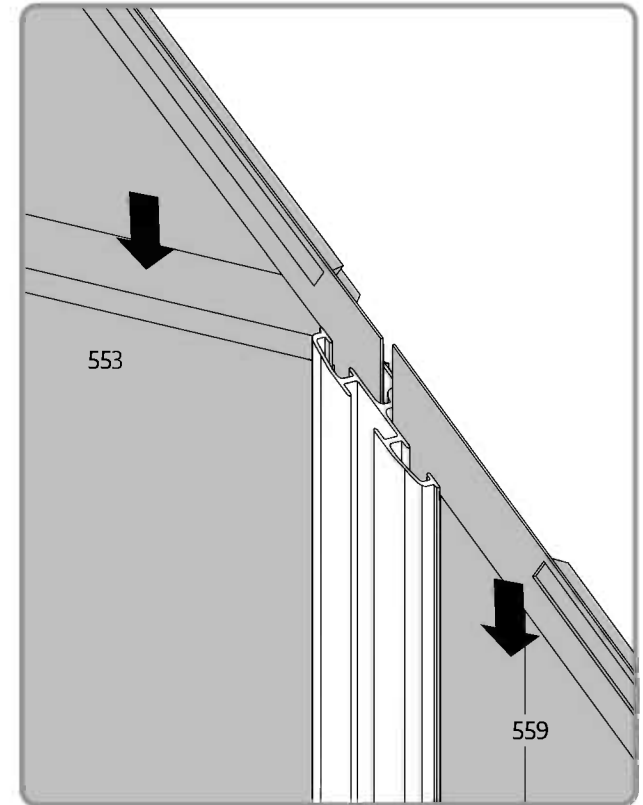
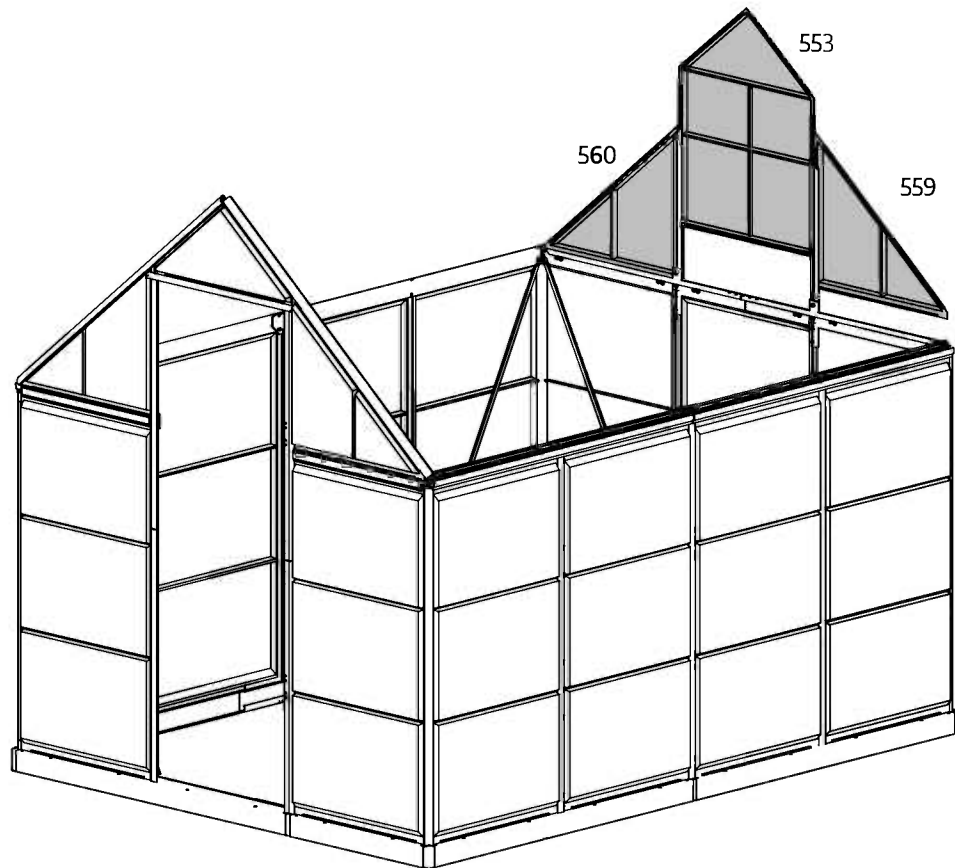
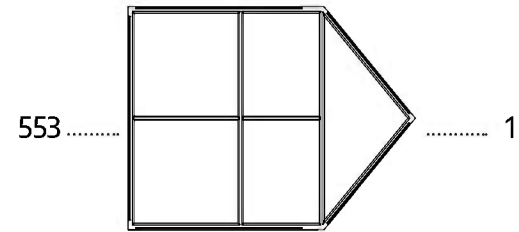
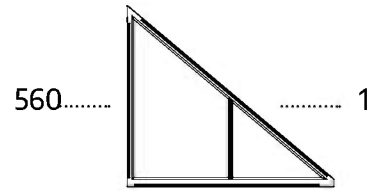
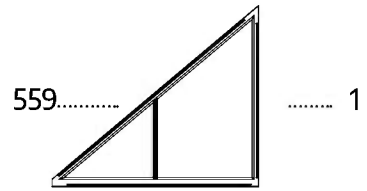
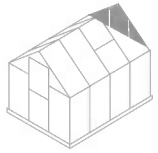

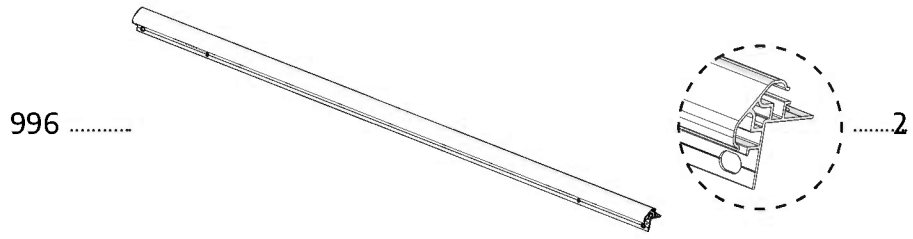



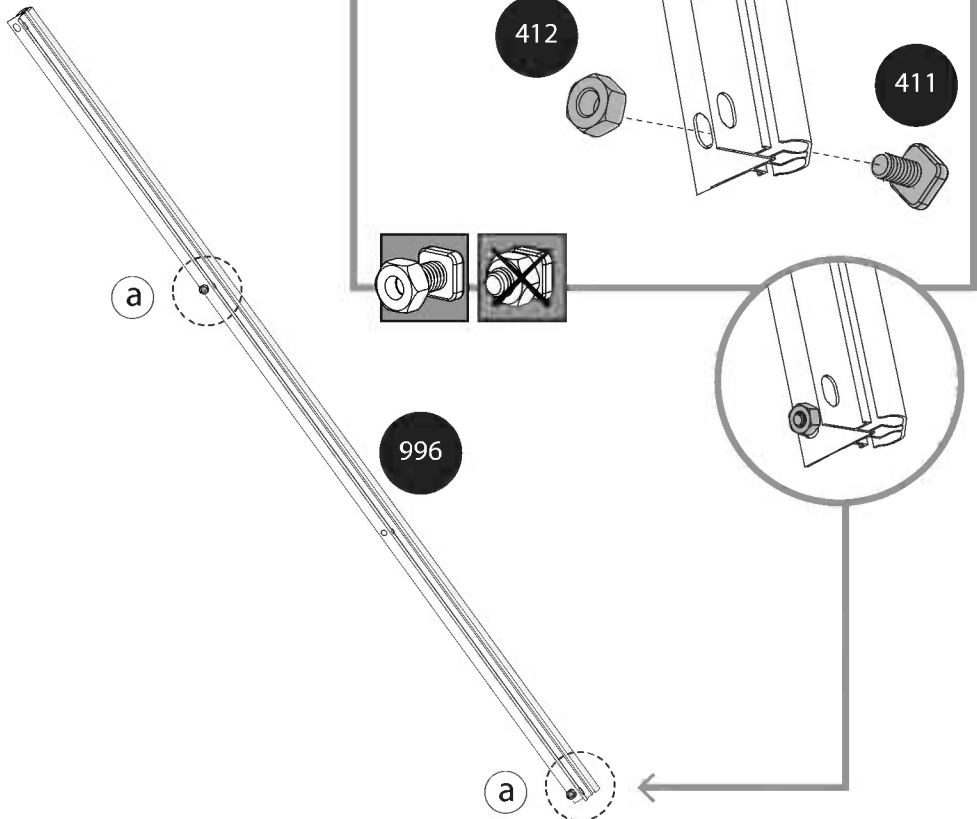
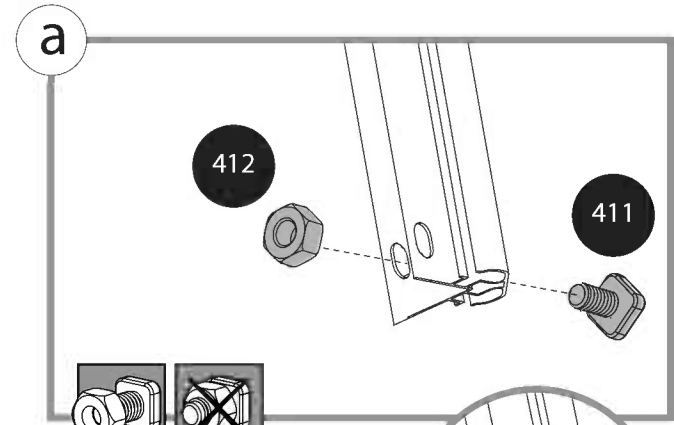
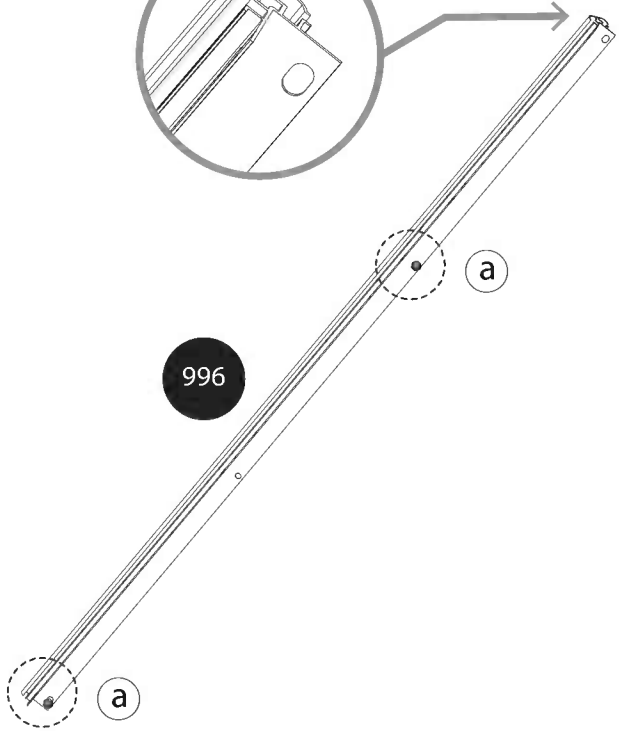
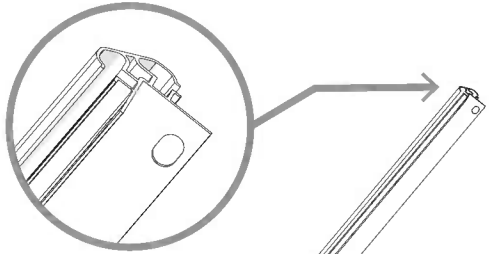

- 411 .....  .....4
- 412 .....  .....4



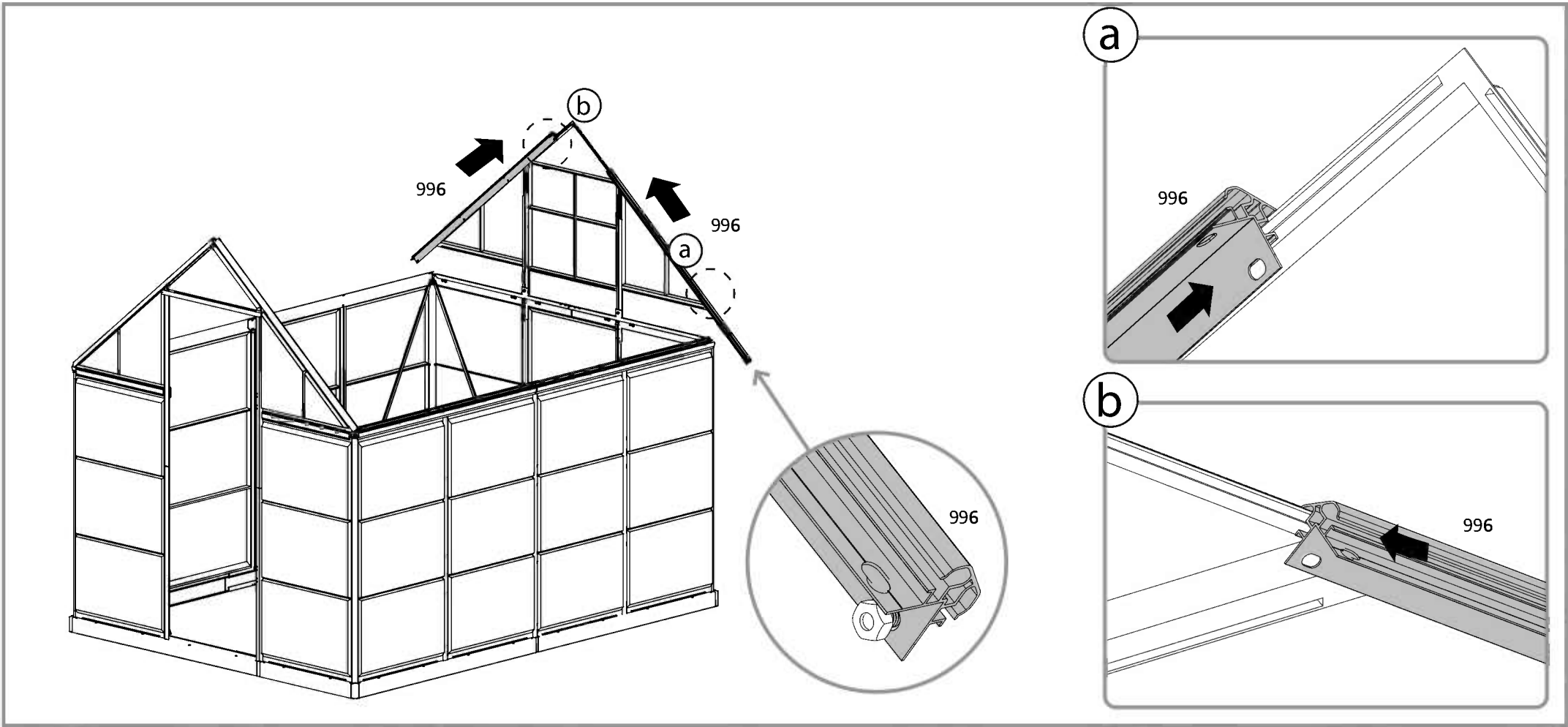
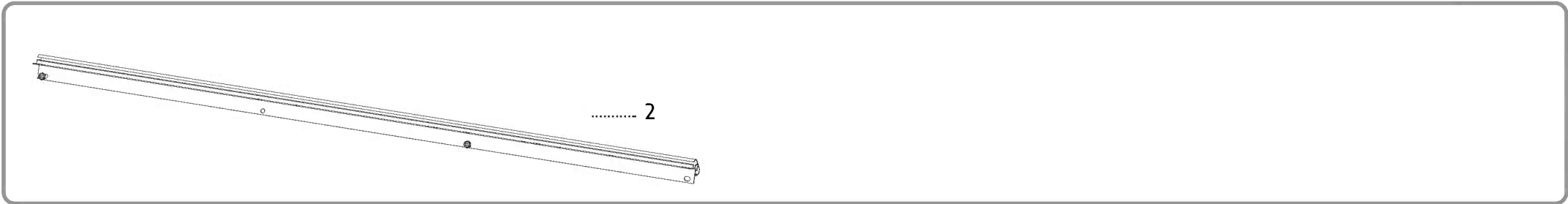
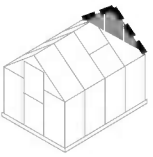

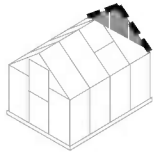



411 .....  .....2      412 .....  .....2

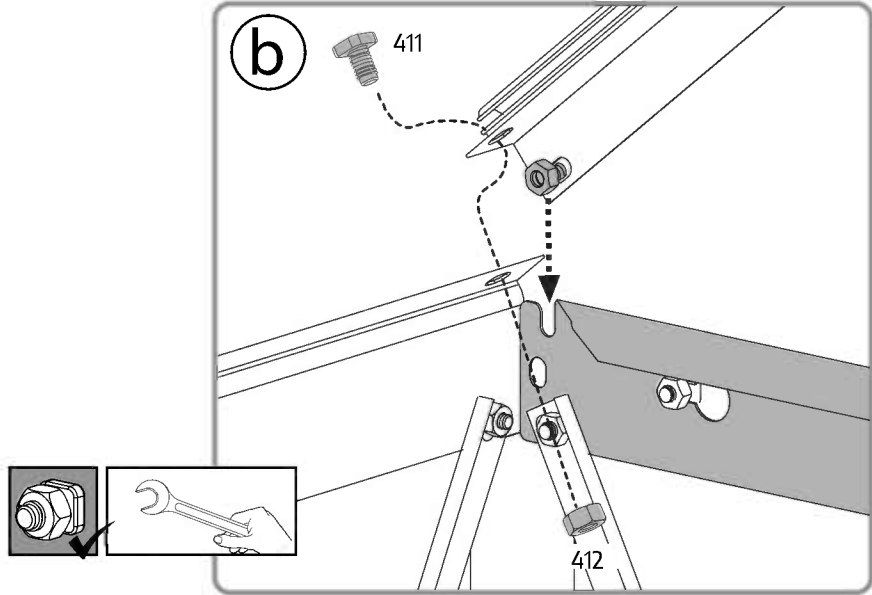
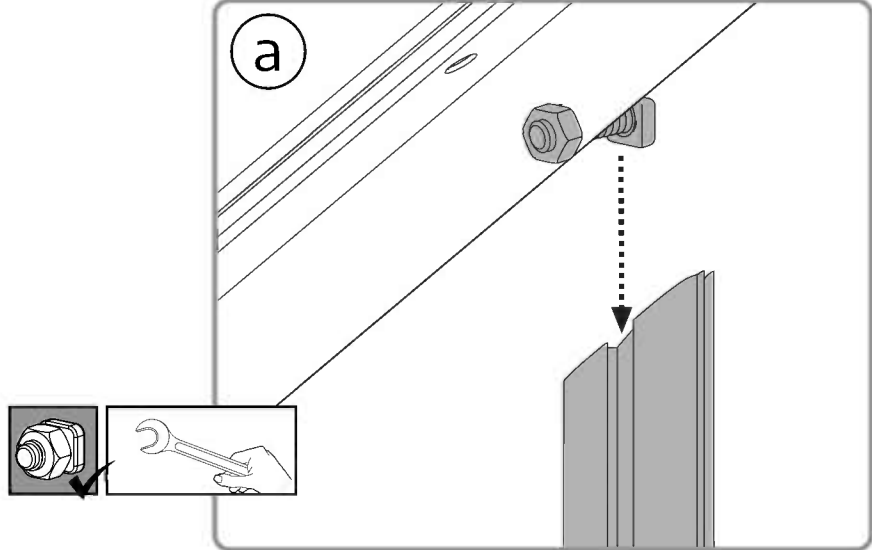
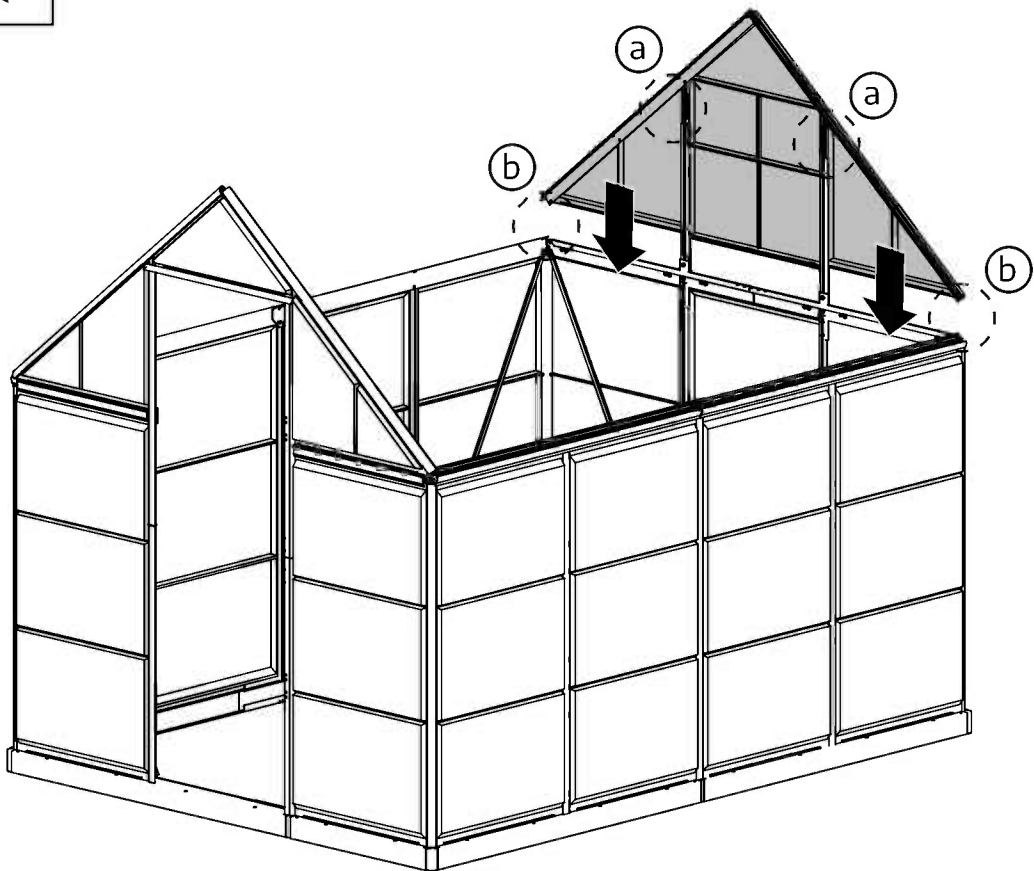

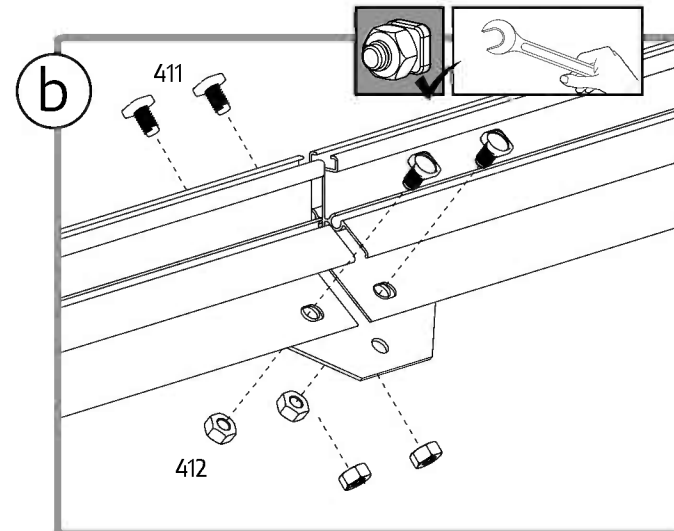
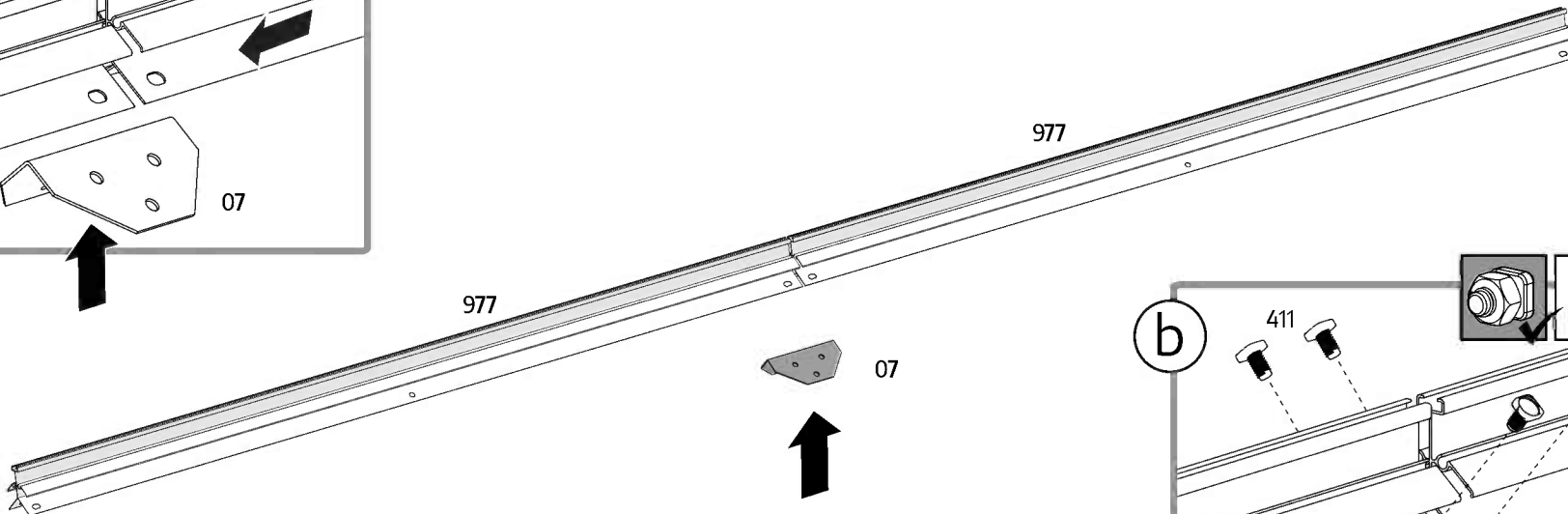
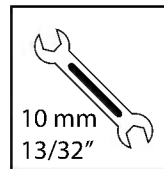
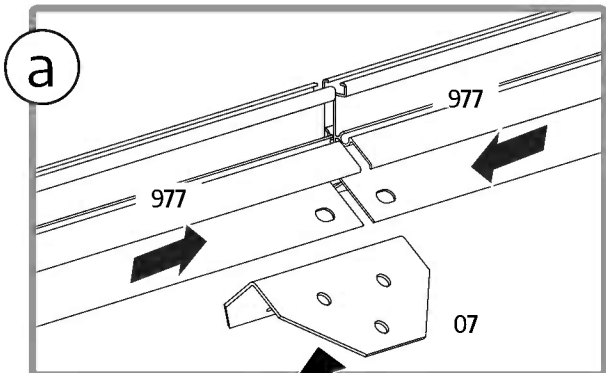
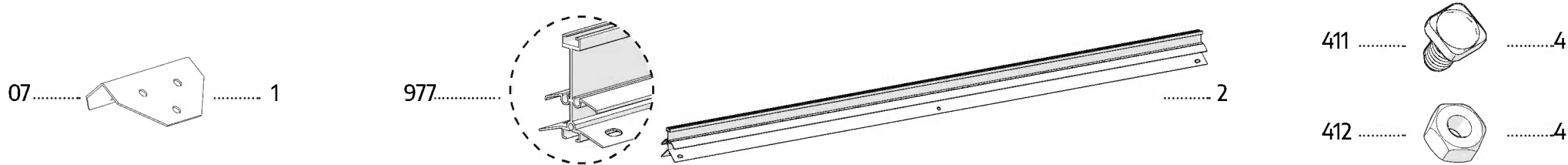

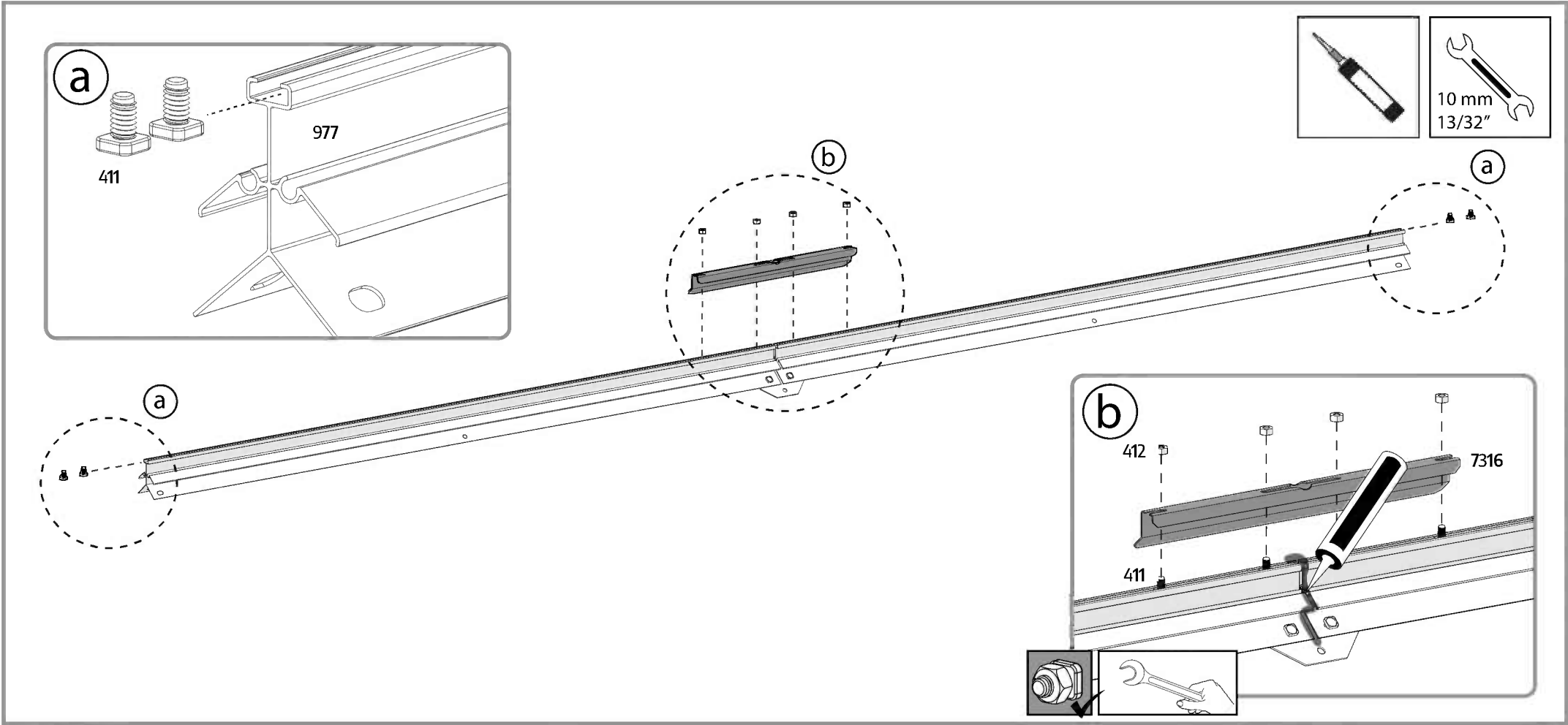
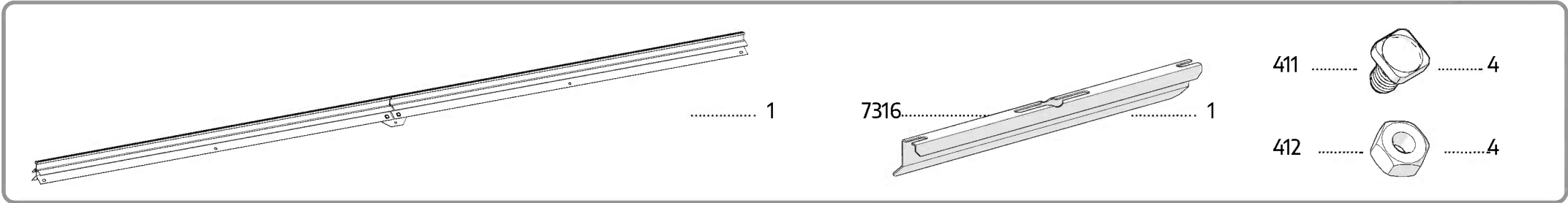

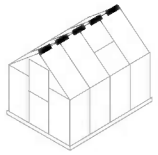

411 ..... 6



412 ..... 6

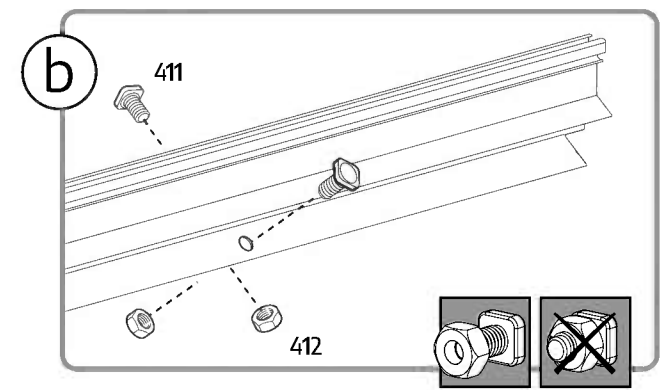
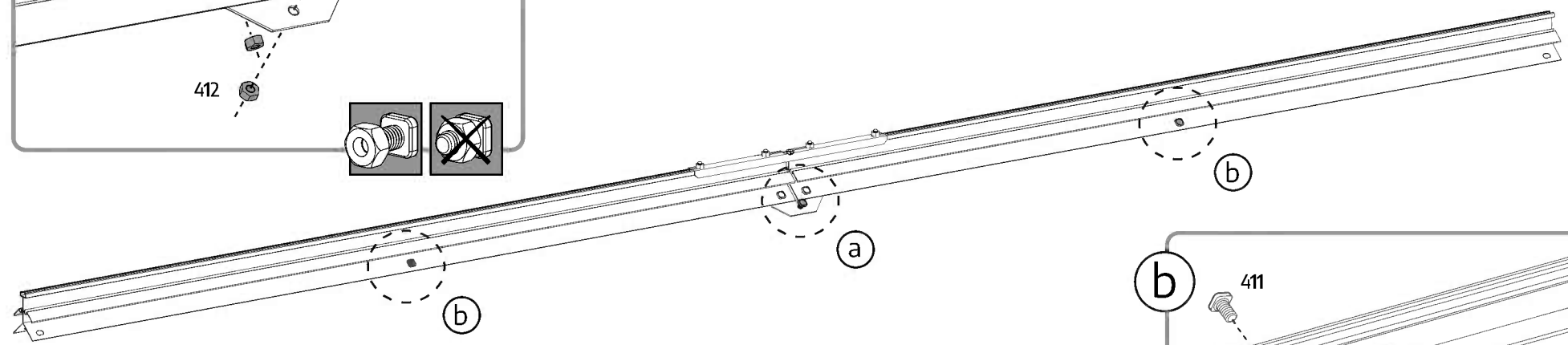
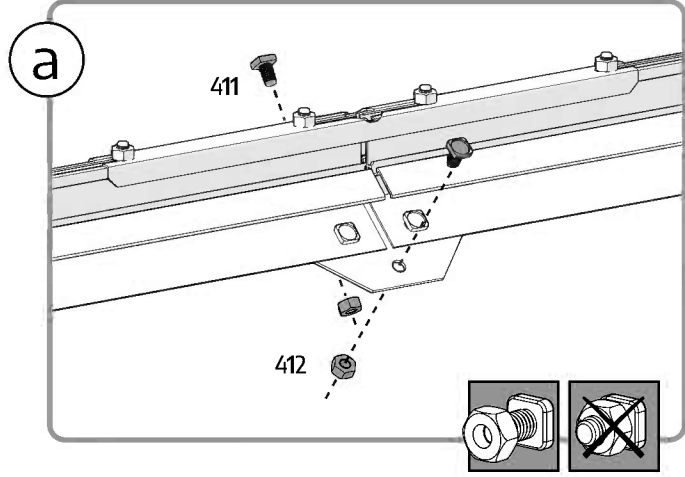



Decide on the window's location before assembly.  
Window can be installed in one of the indicated options.

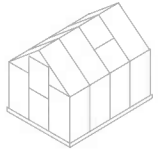

**EN** Windows Location

**GR** Fenster Standort

**FR** Fenêtre Emplacement

**SP** Ventana Ubicación

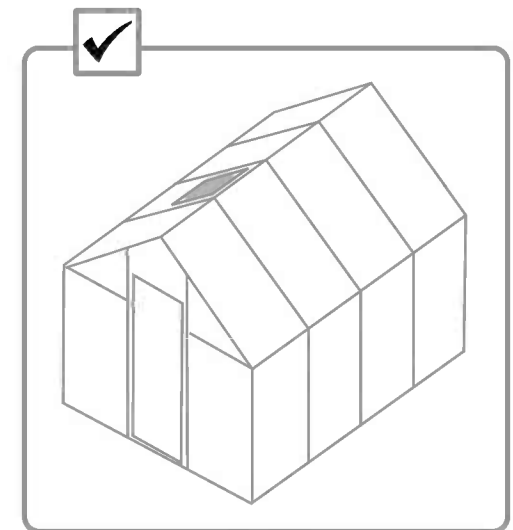
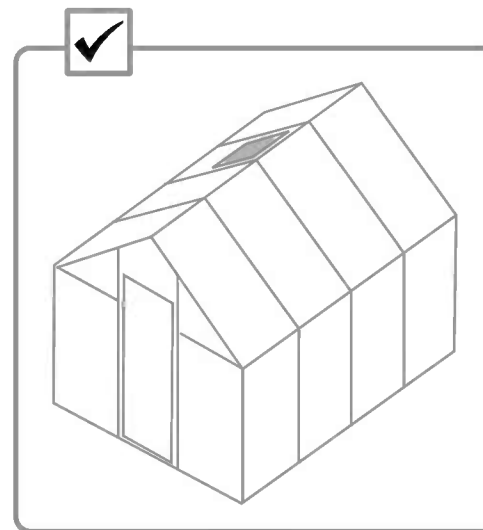
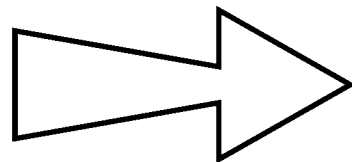
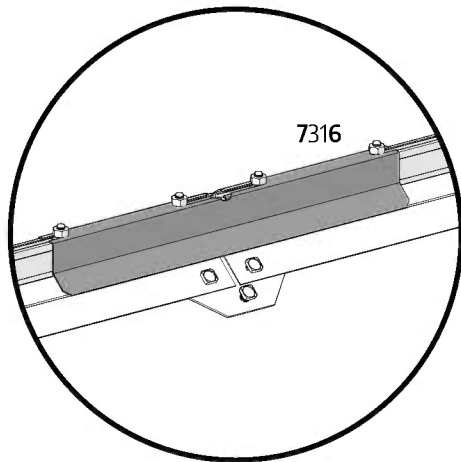
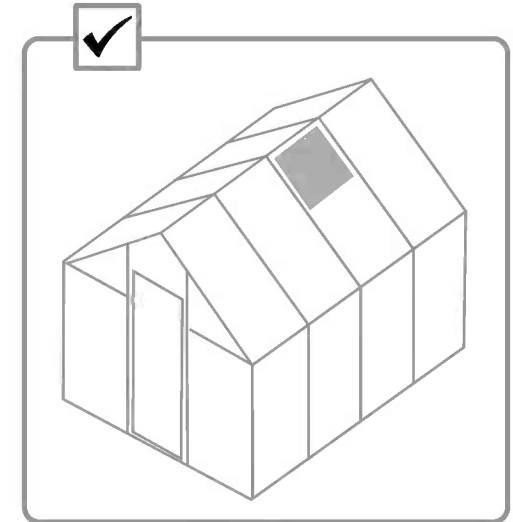
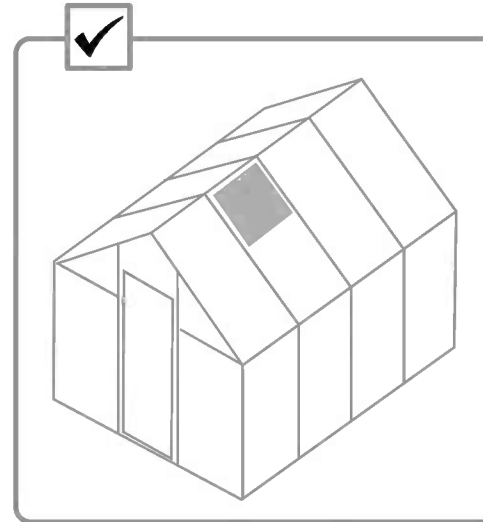
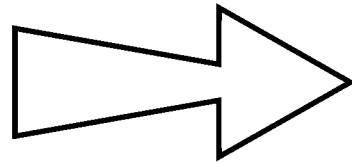
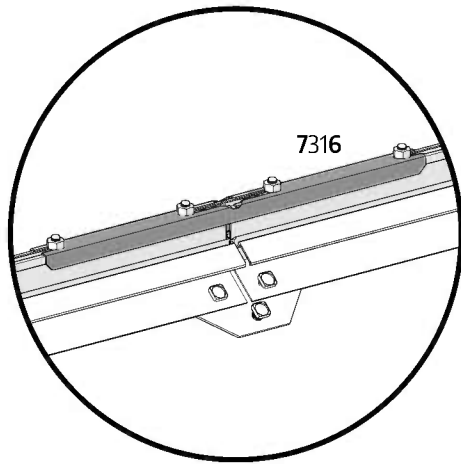



Once the window location is chosen, please turn part #7316 into the correct position accordingly.

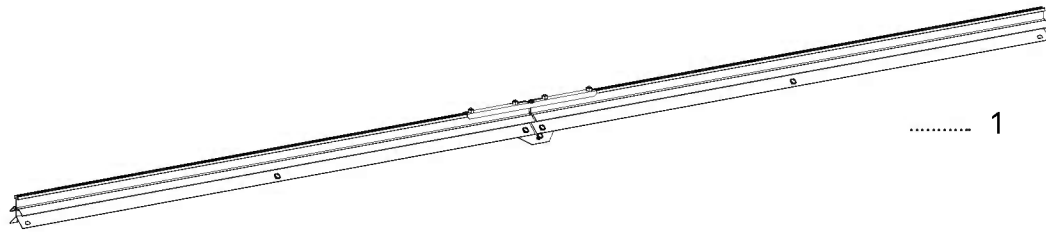
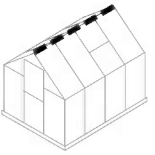

..... 1



411..... 4



412..... 4

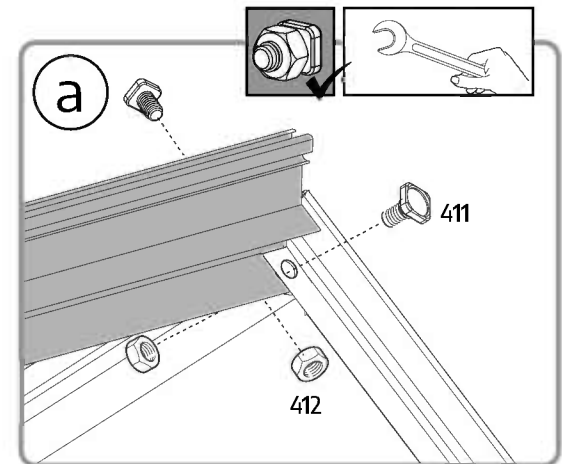
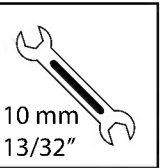
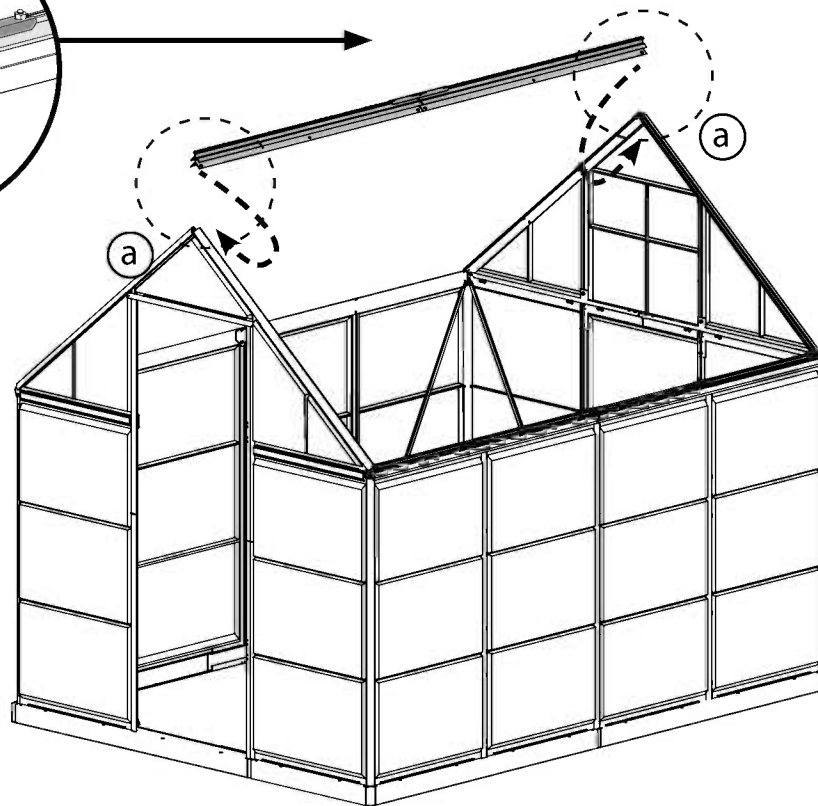
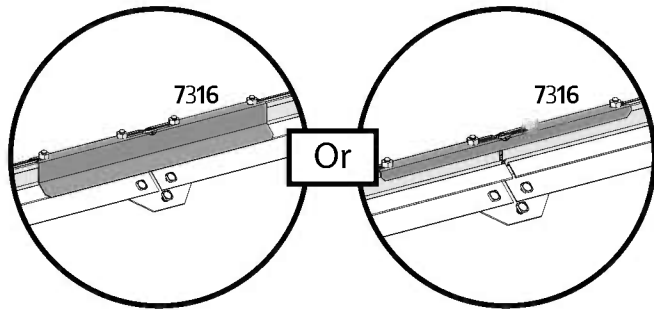

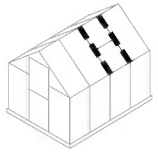

993.....

.....2

8710..... 2

411 ..... 4

412 .....4

**a**

8710

411

412

**b**

993

993



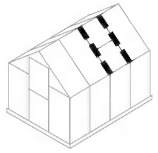

..... 2



411 .....

..... 2



412 .....

..... 2

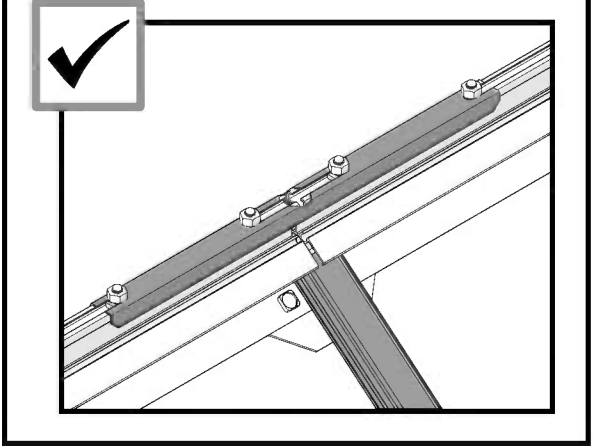
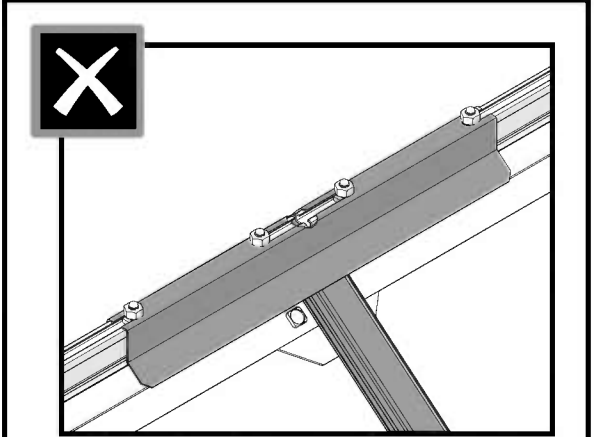
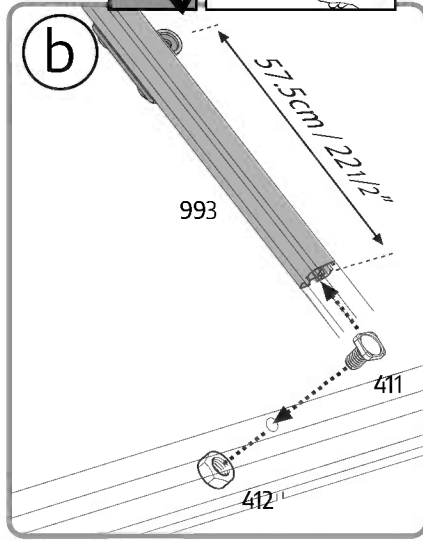
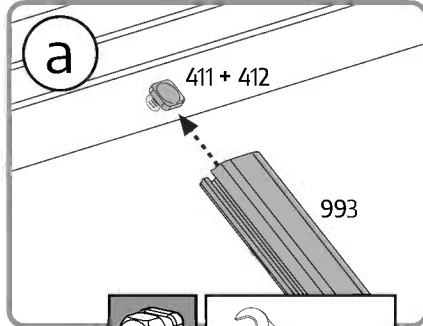
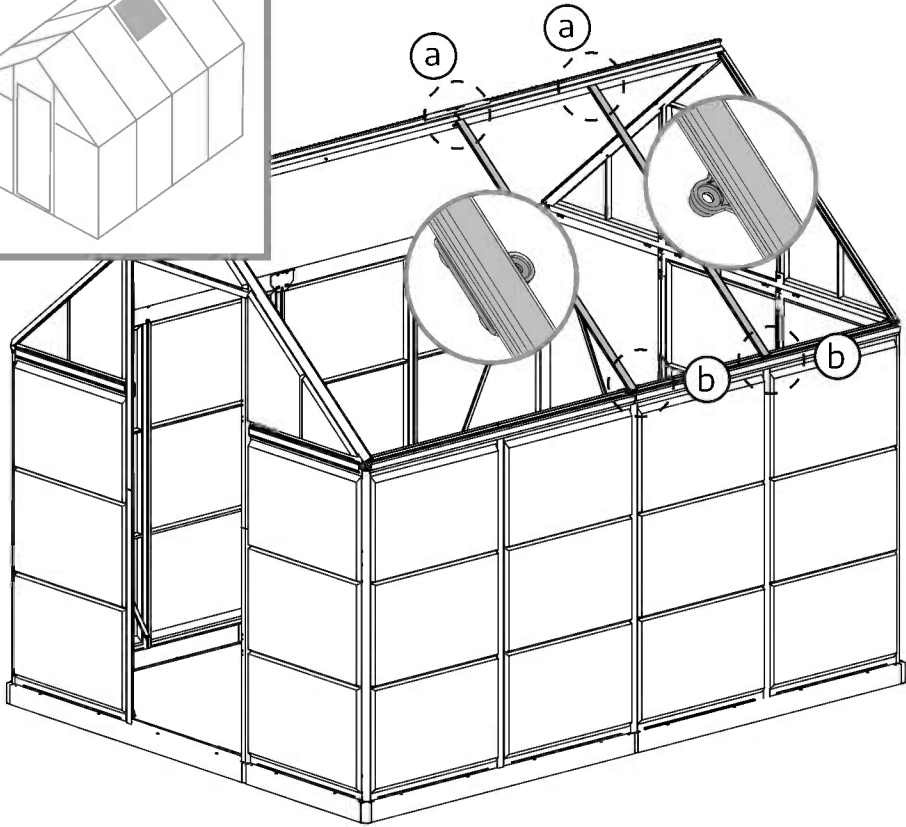
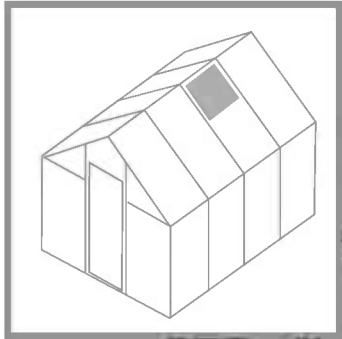

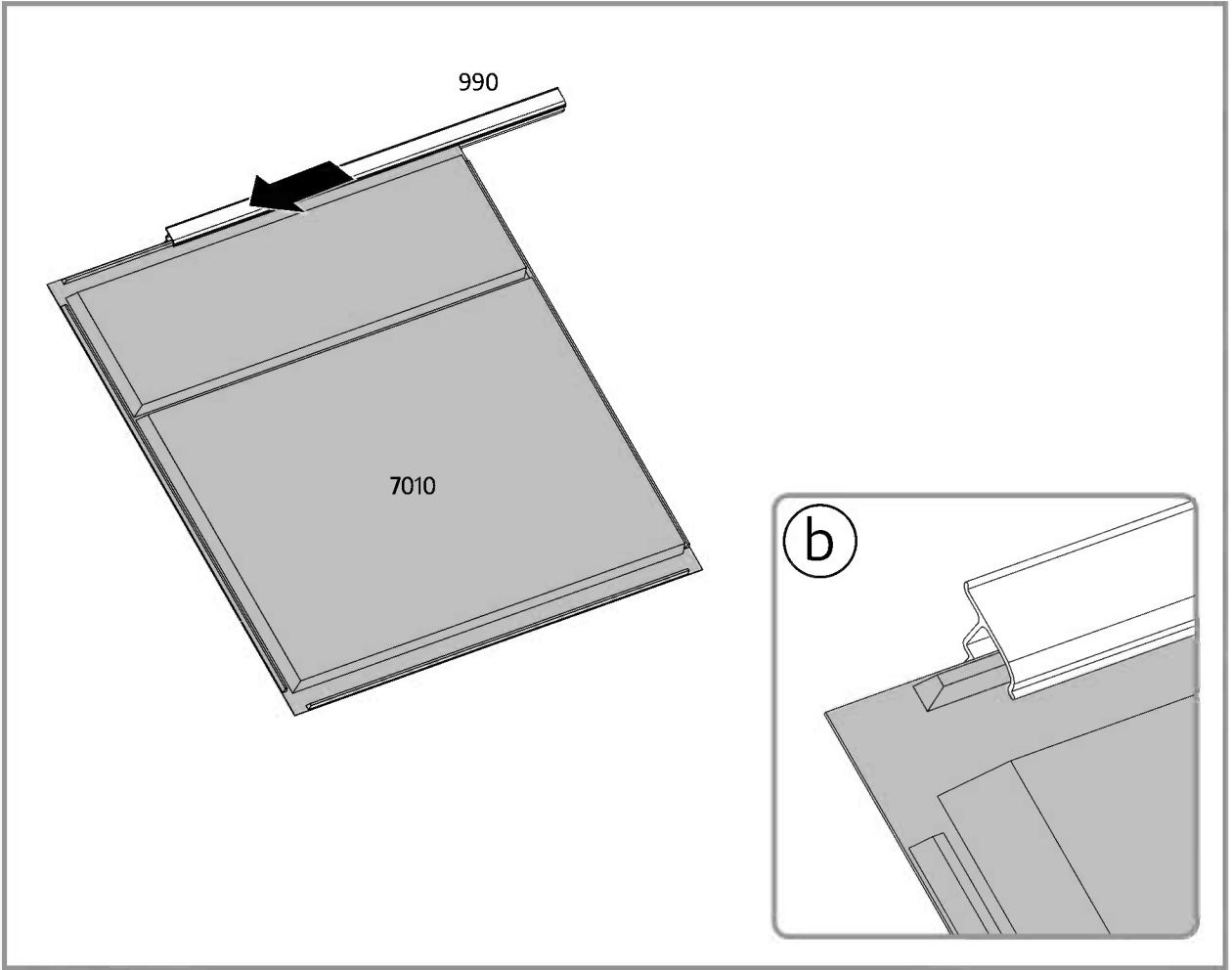
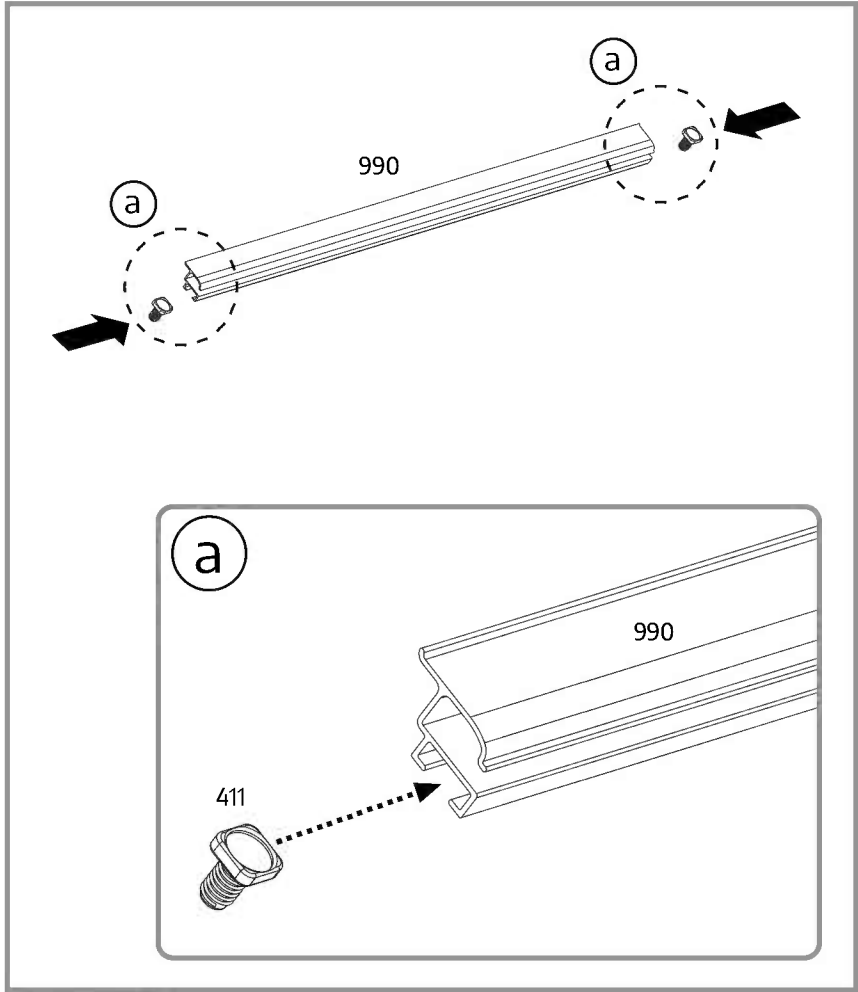
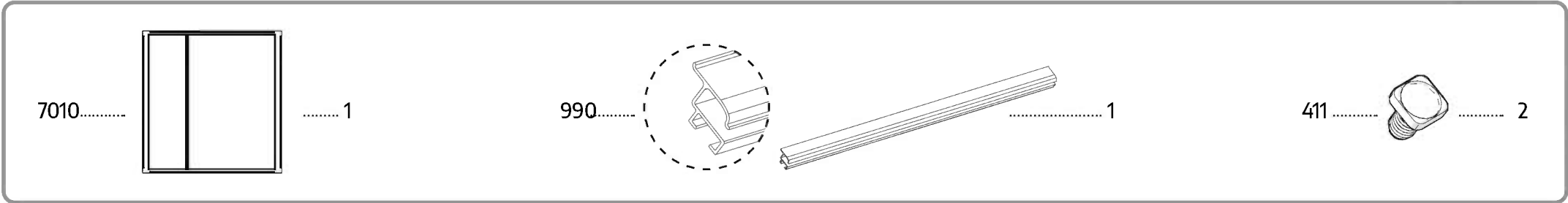
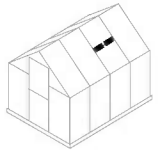

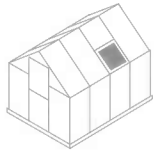

7010 + 990 .....

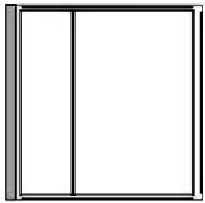

.....1

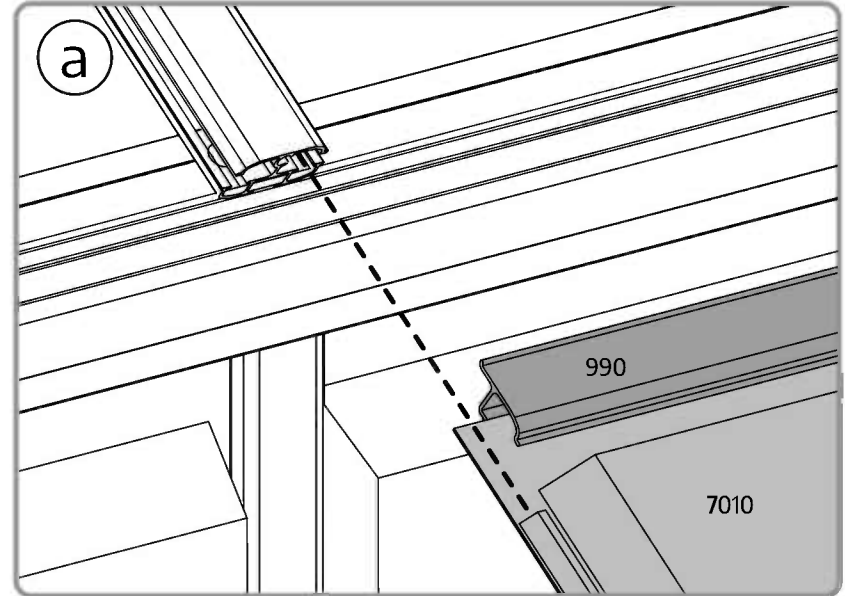
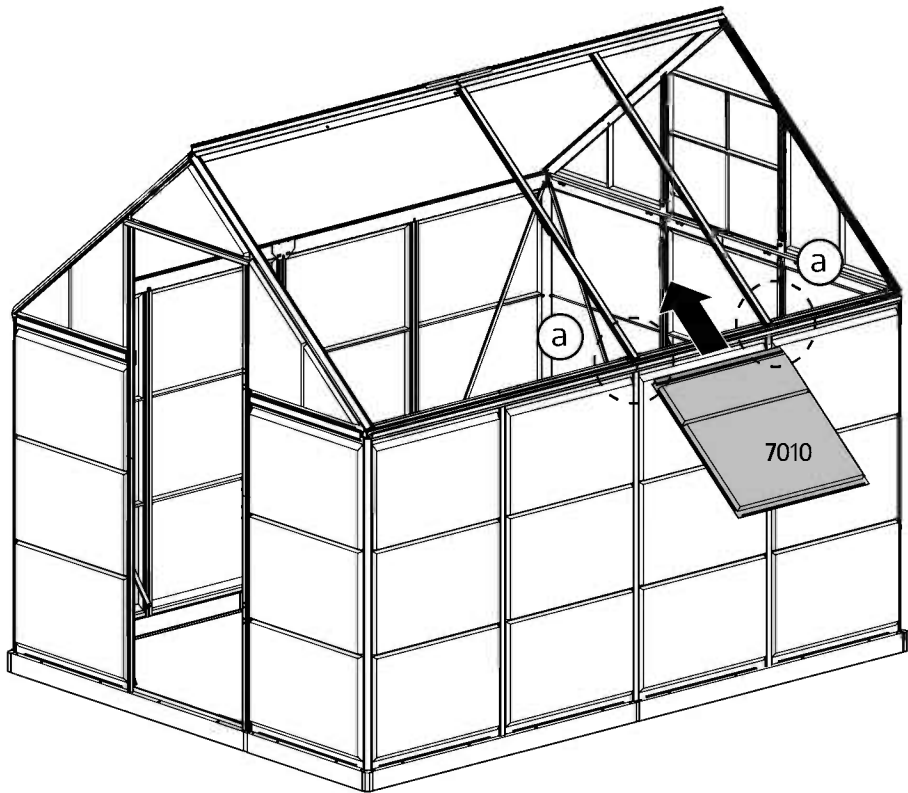

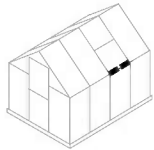

981.....

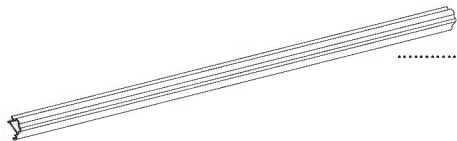
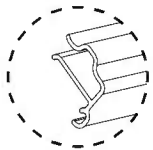

.....1

412.....



.....2

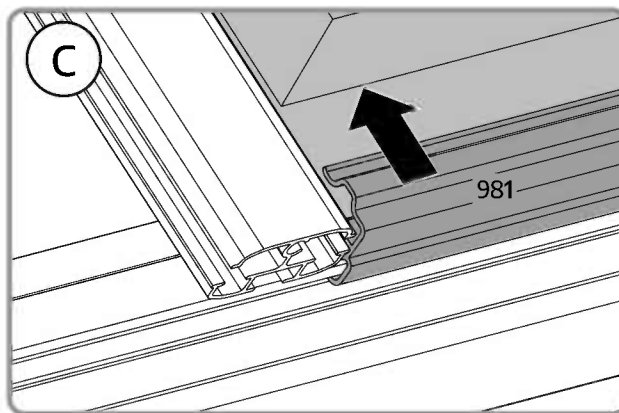
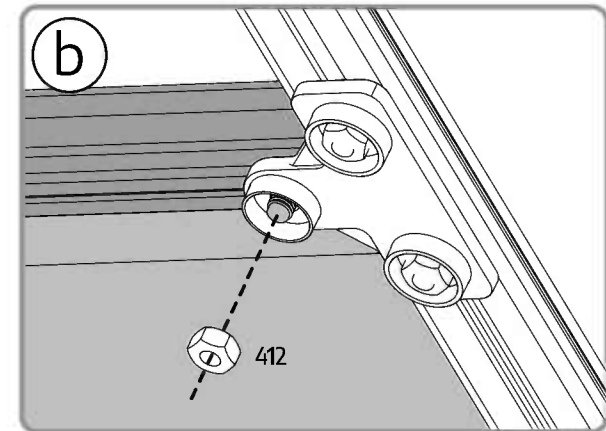
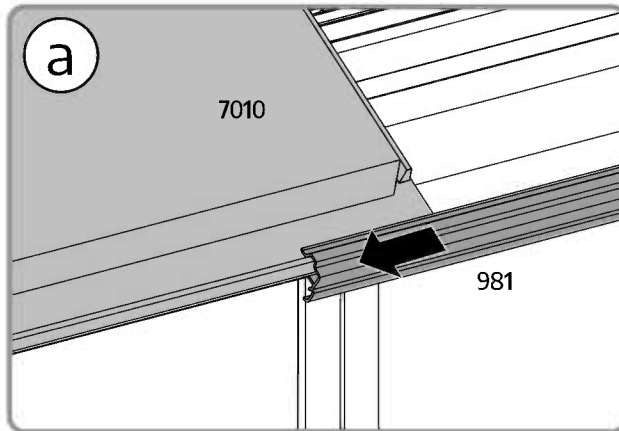
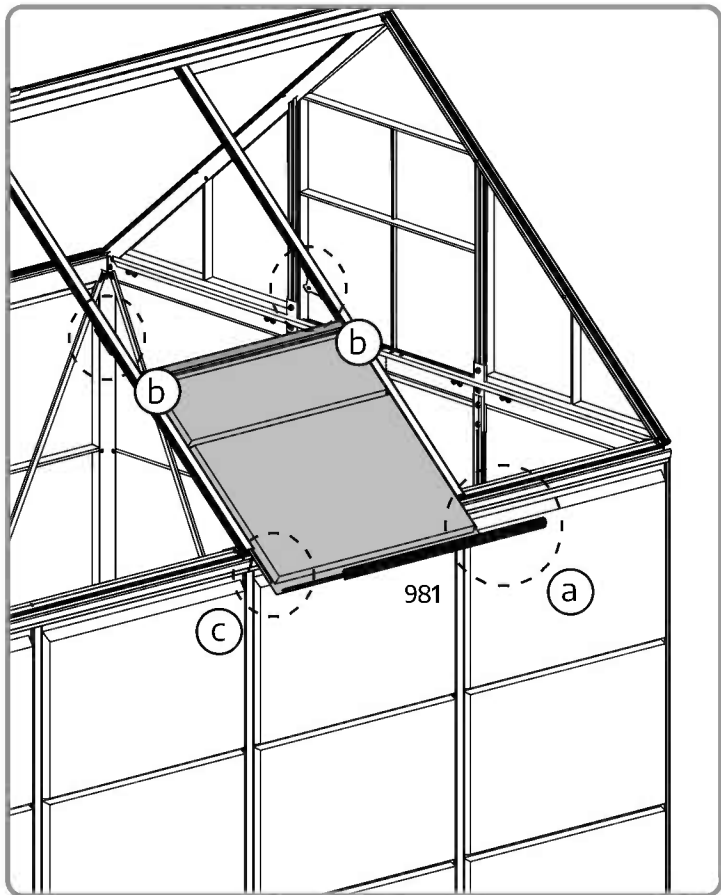

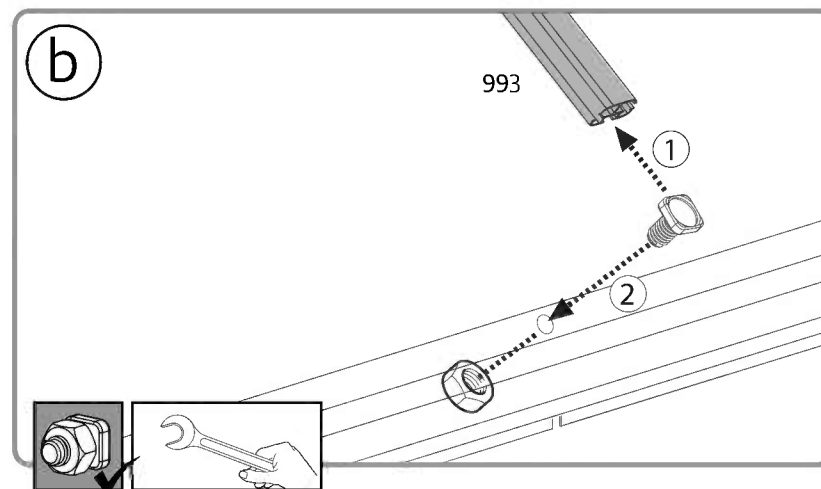
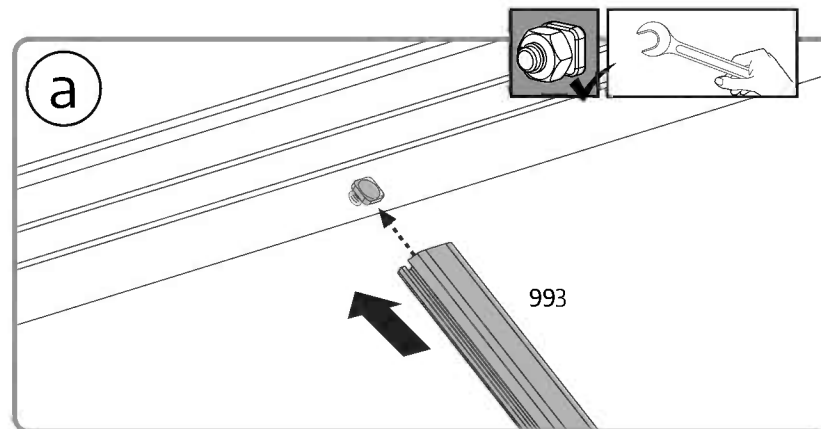
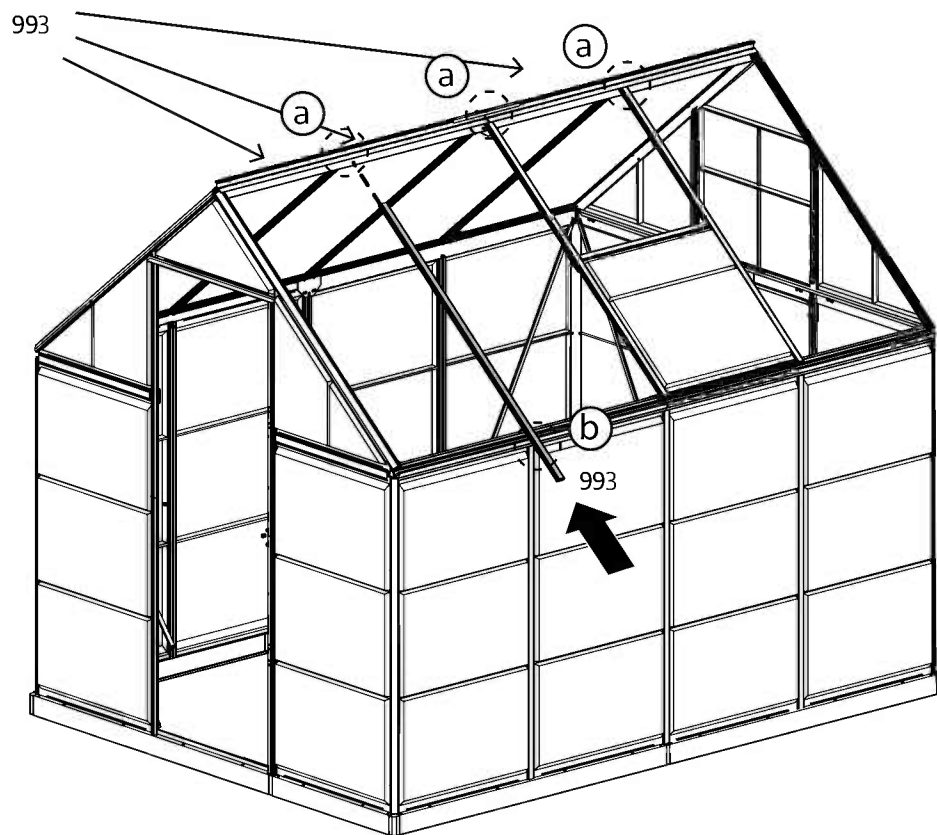
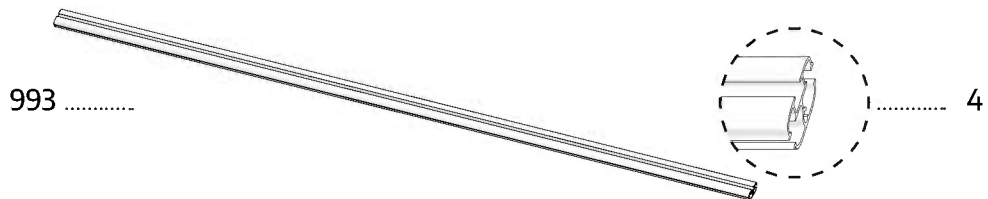
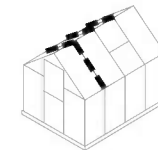

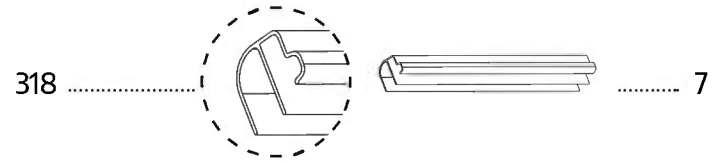
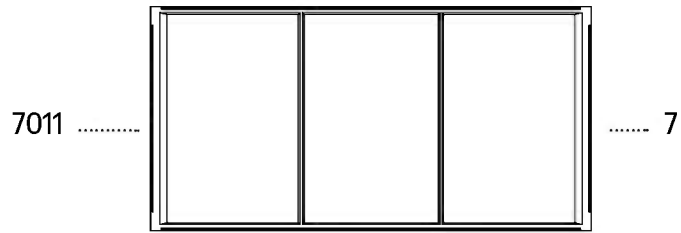
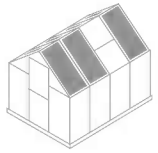

x7

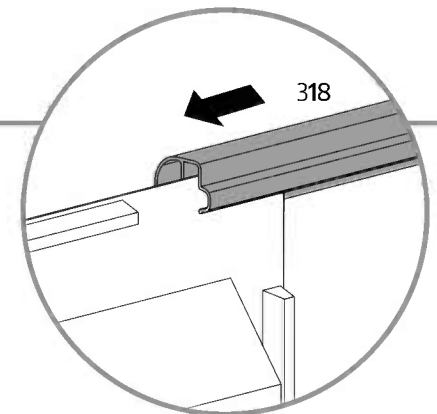
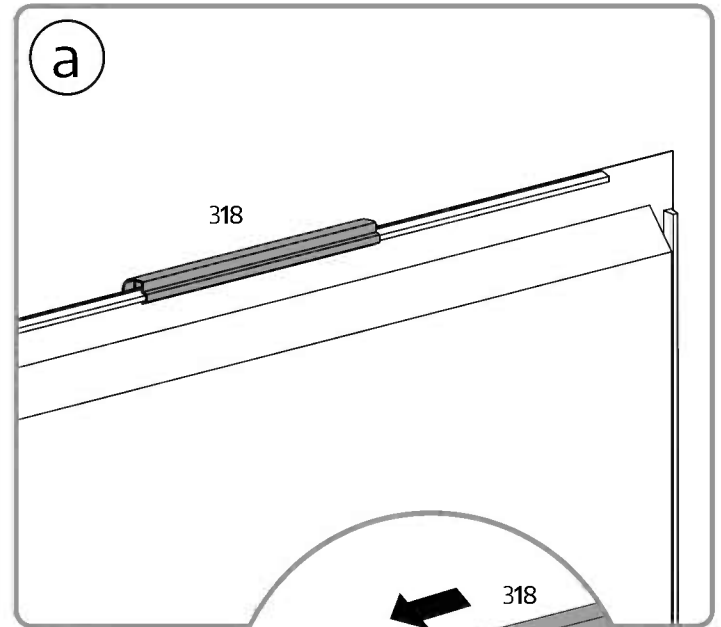
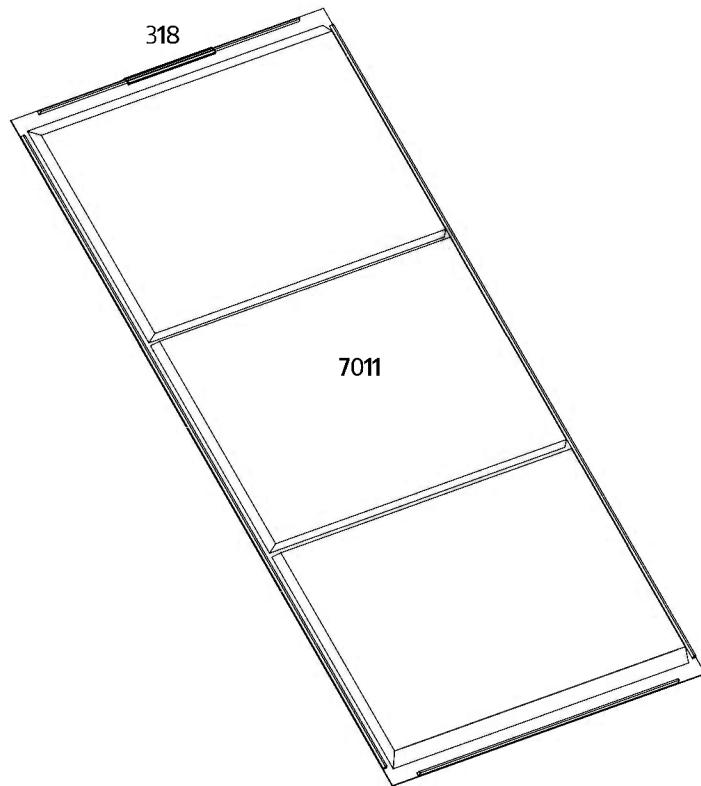

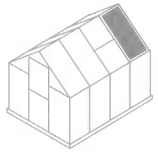

7011 + 318 ..... 1



..... 1

981.....



..... 1

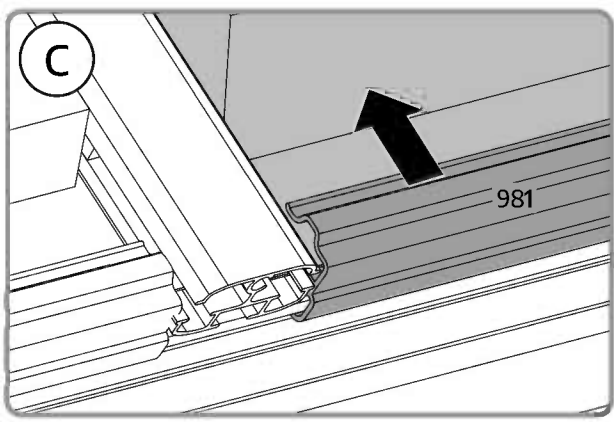
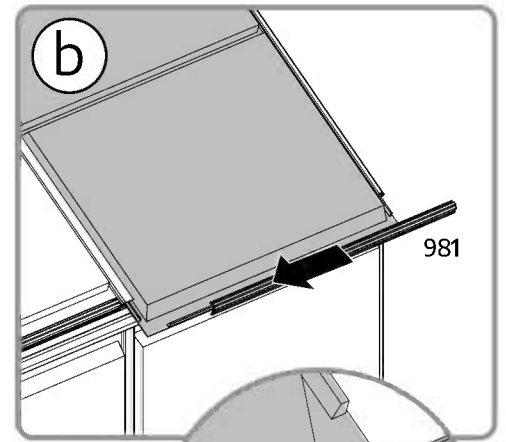
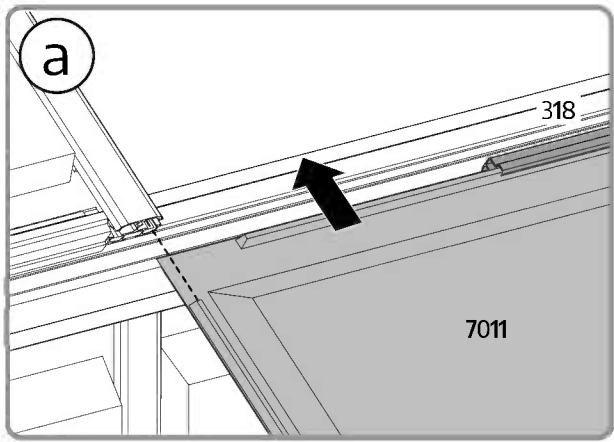
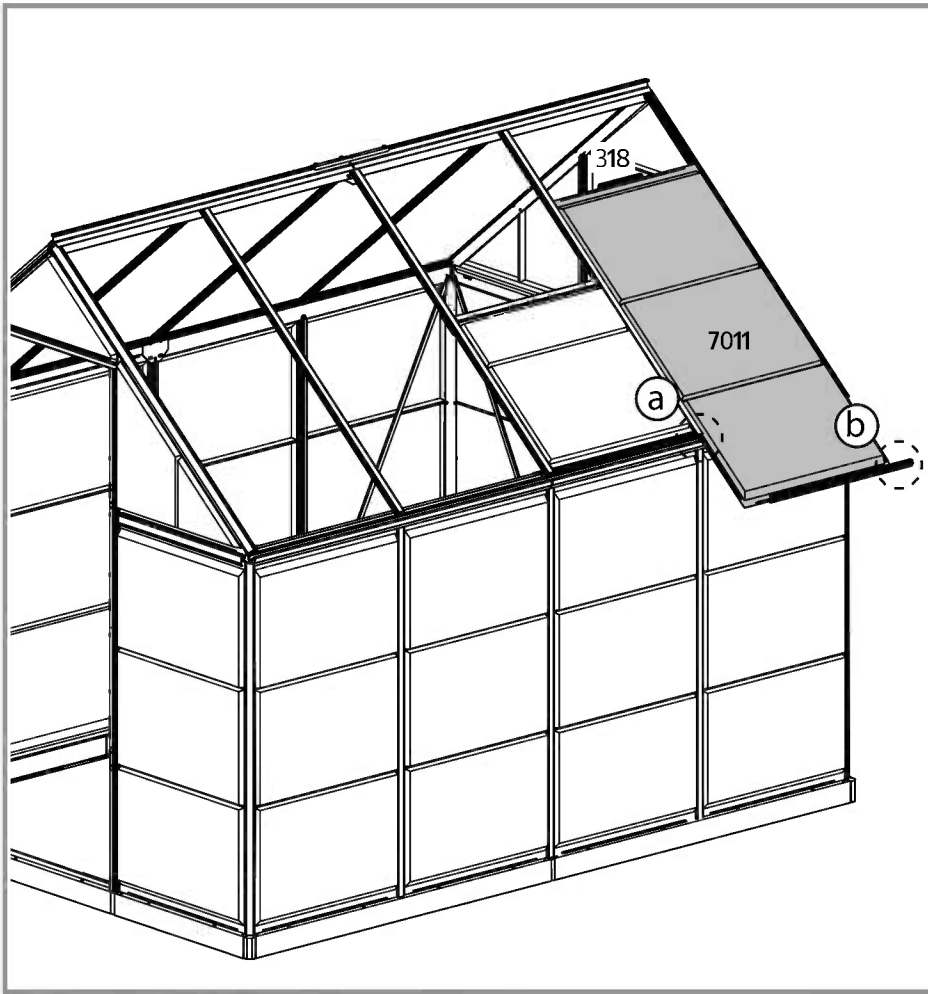

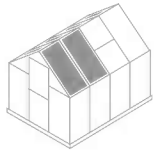

7011 + 318 .....

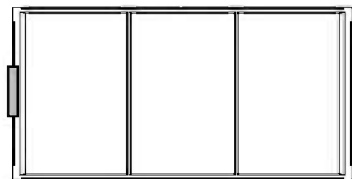

.....6

981 .....

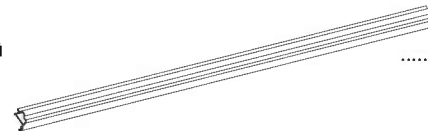

.....6

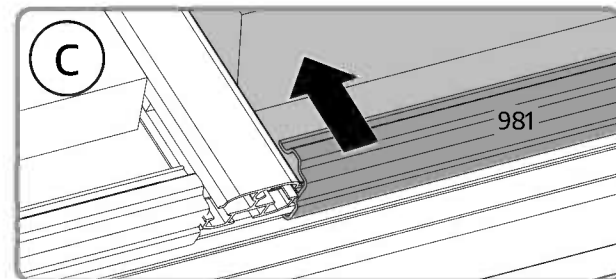
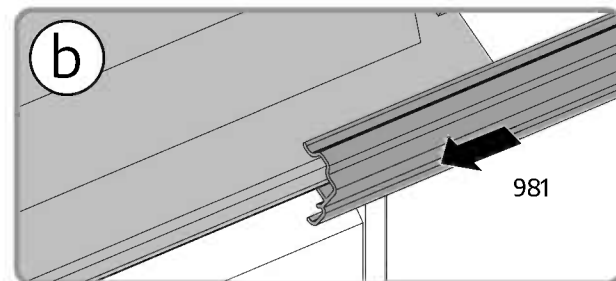
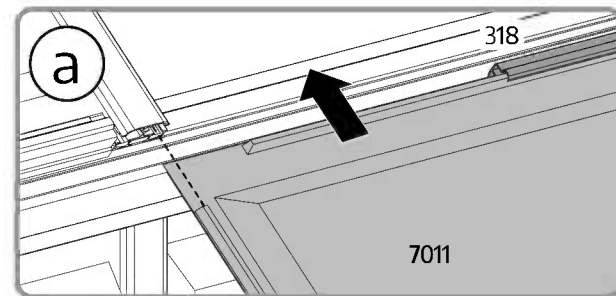
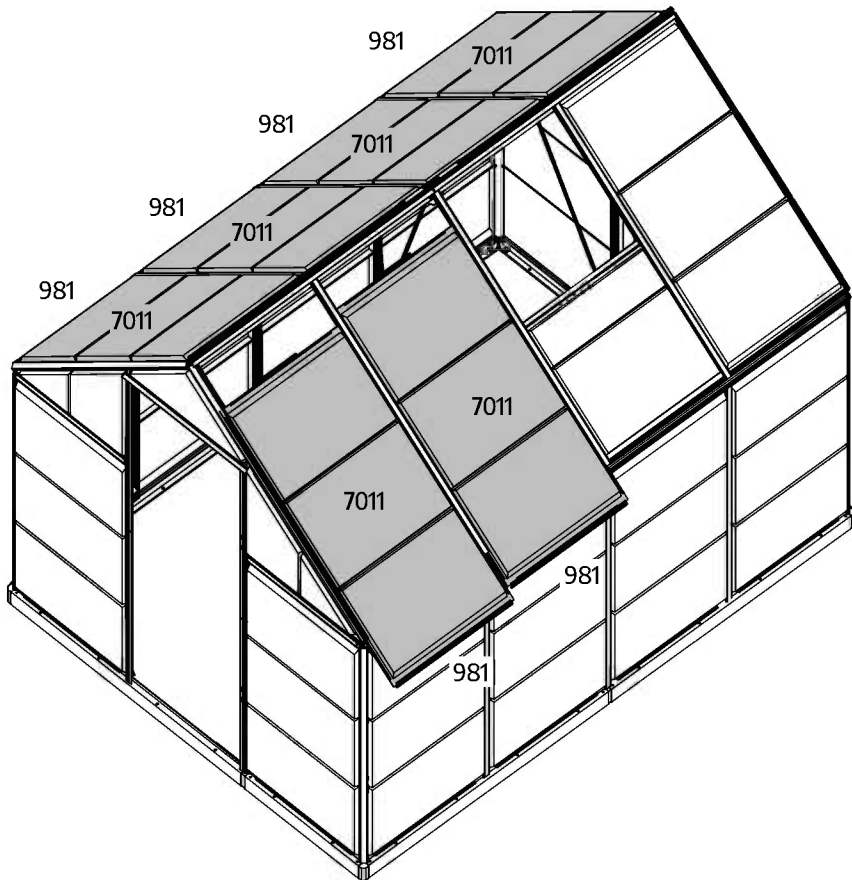



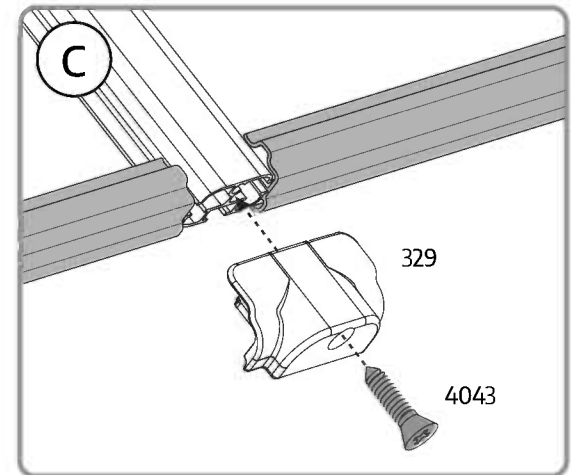
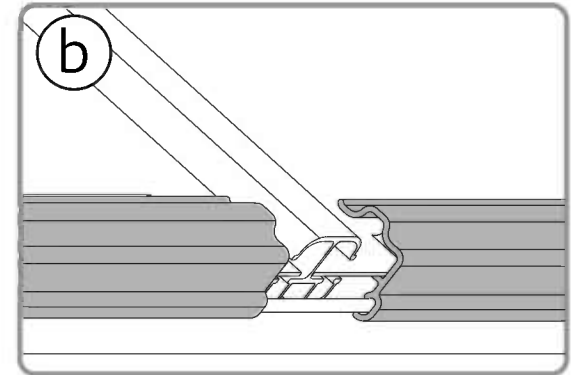
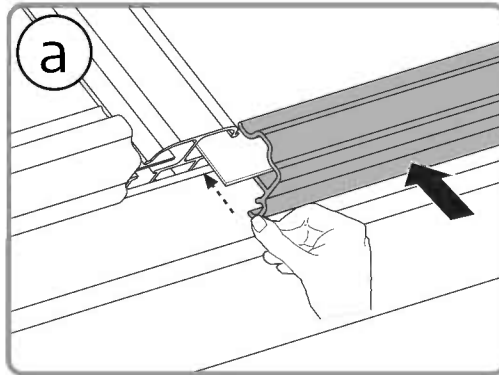
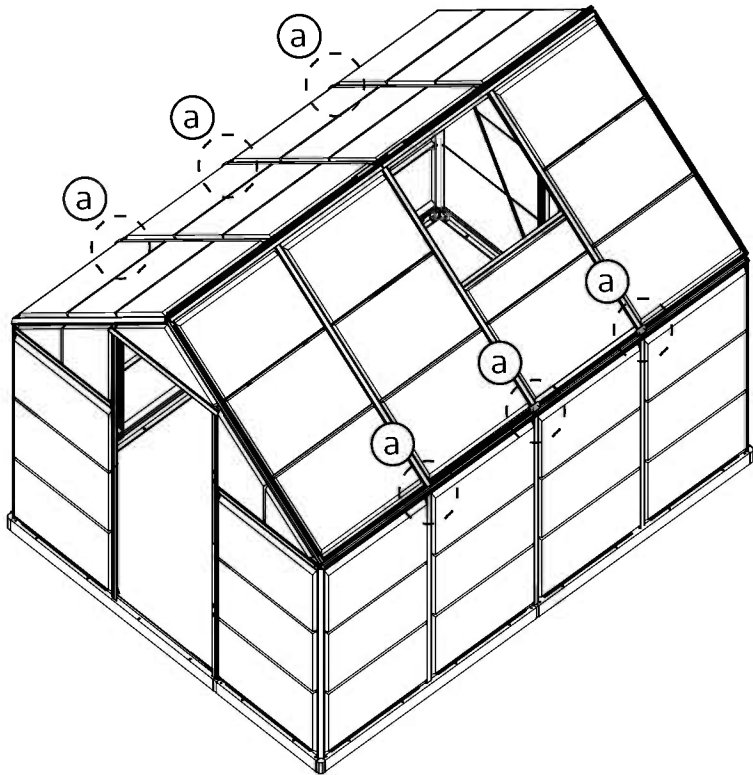
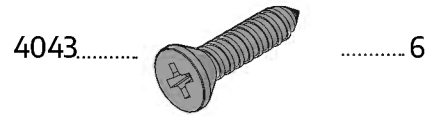
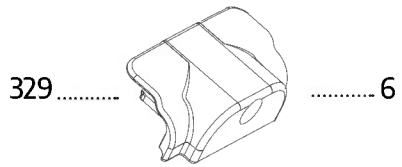
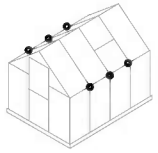

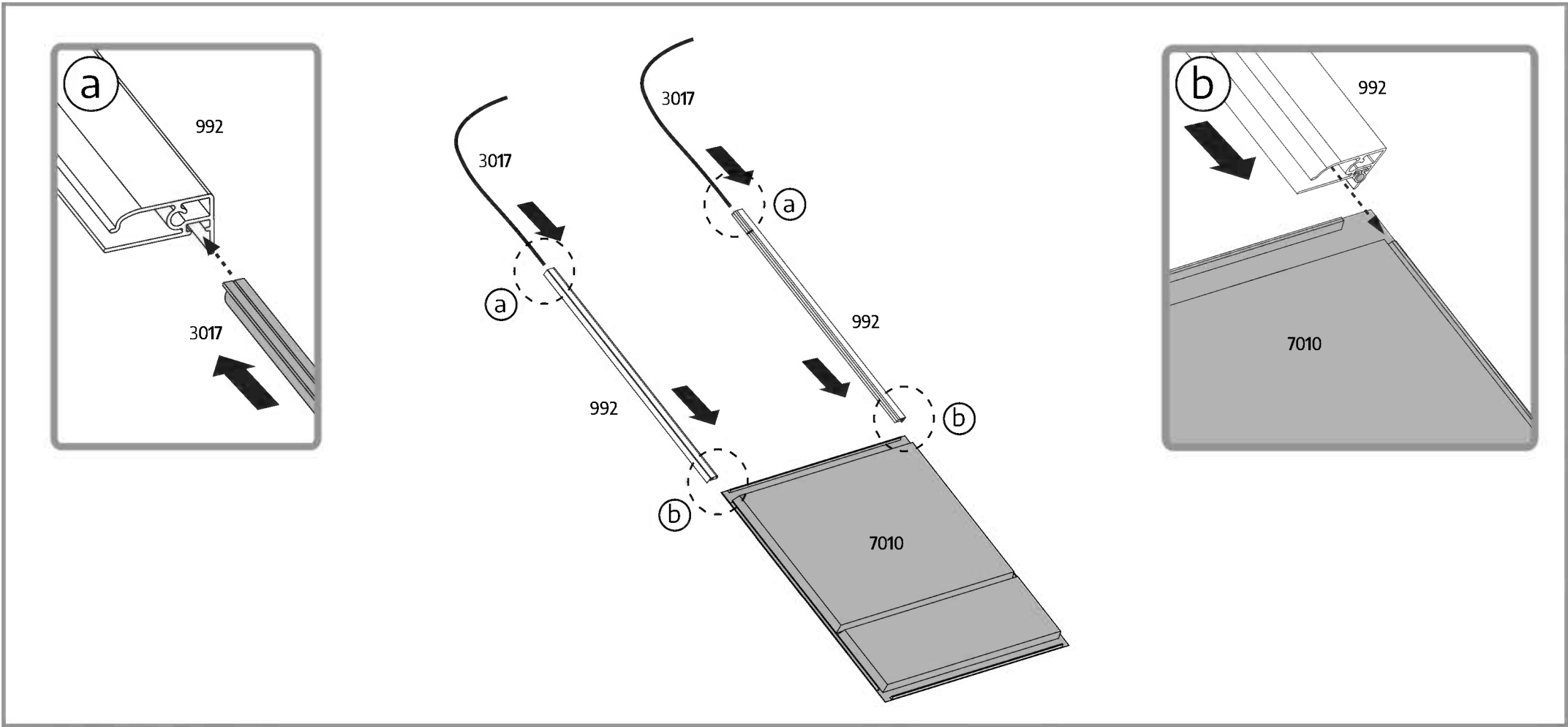
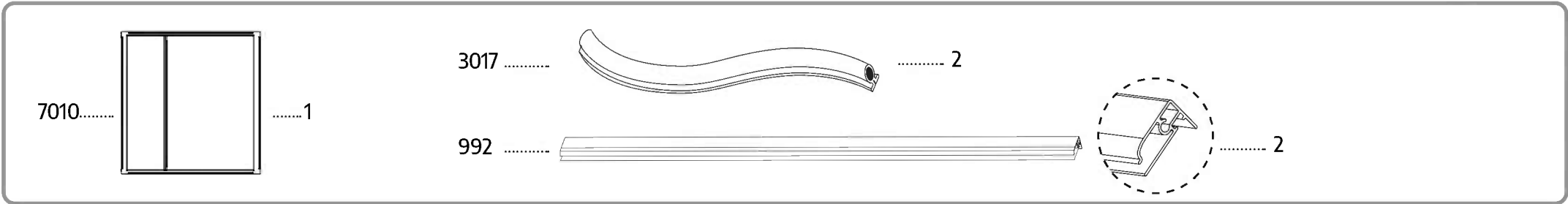
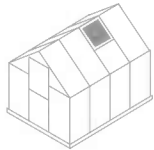

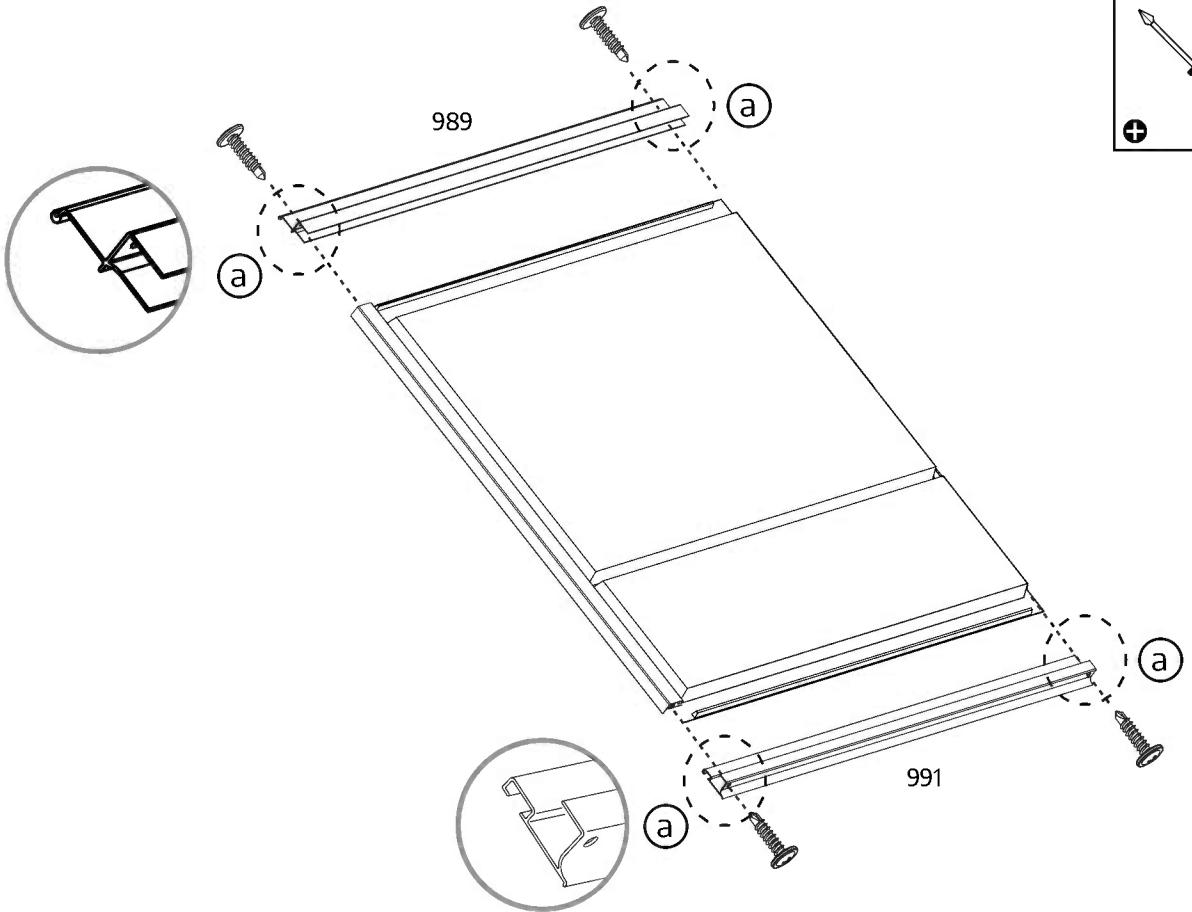
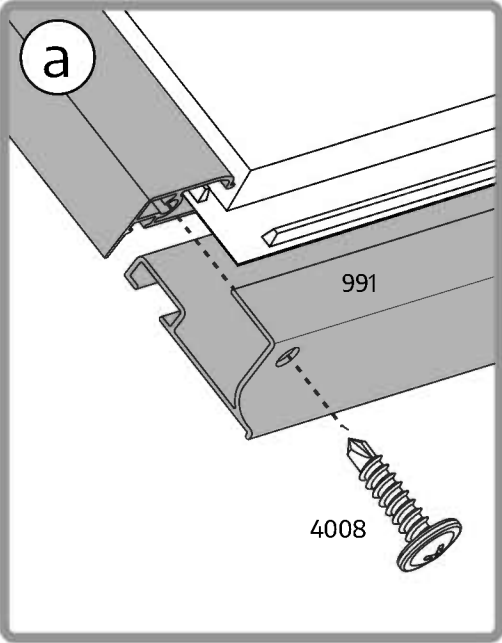
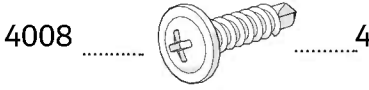
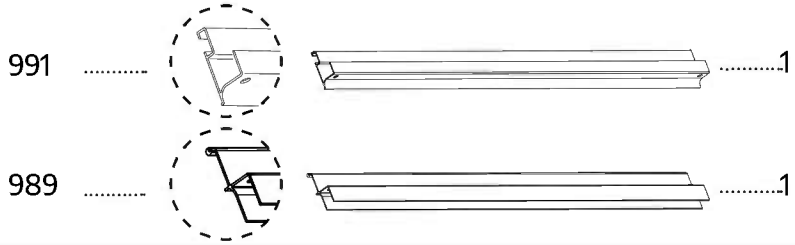
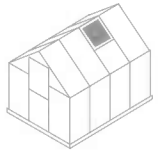

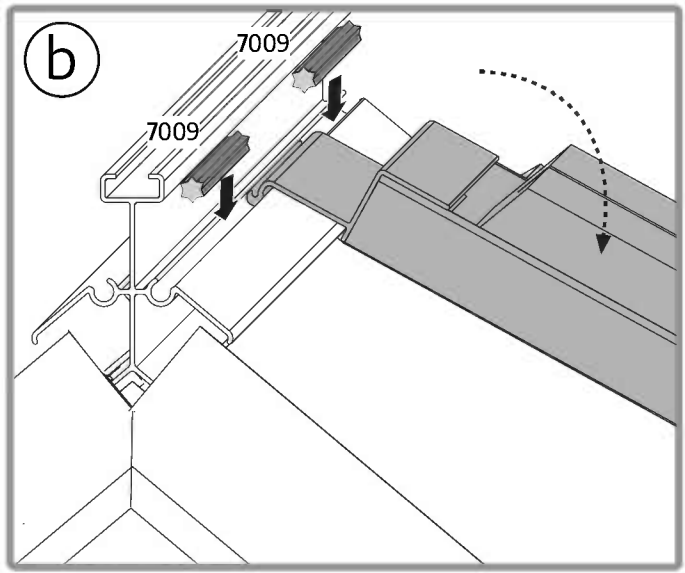
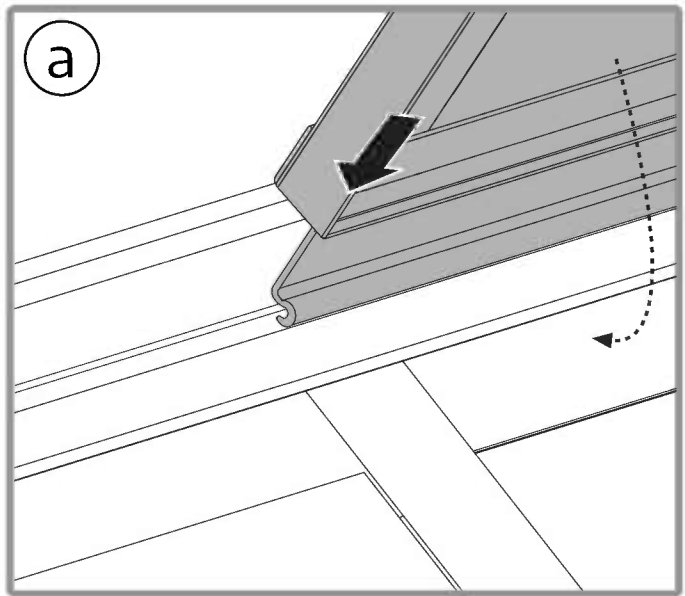
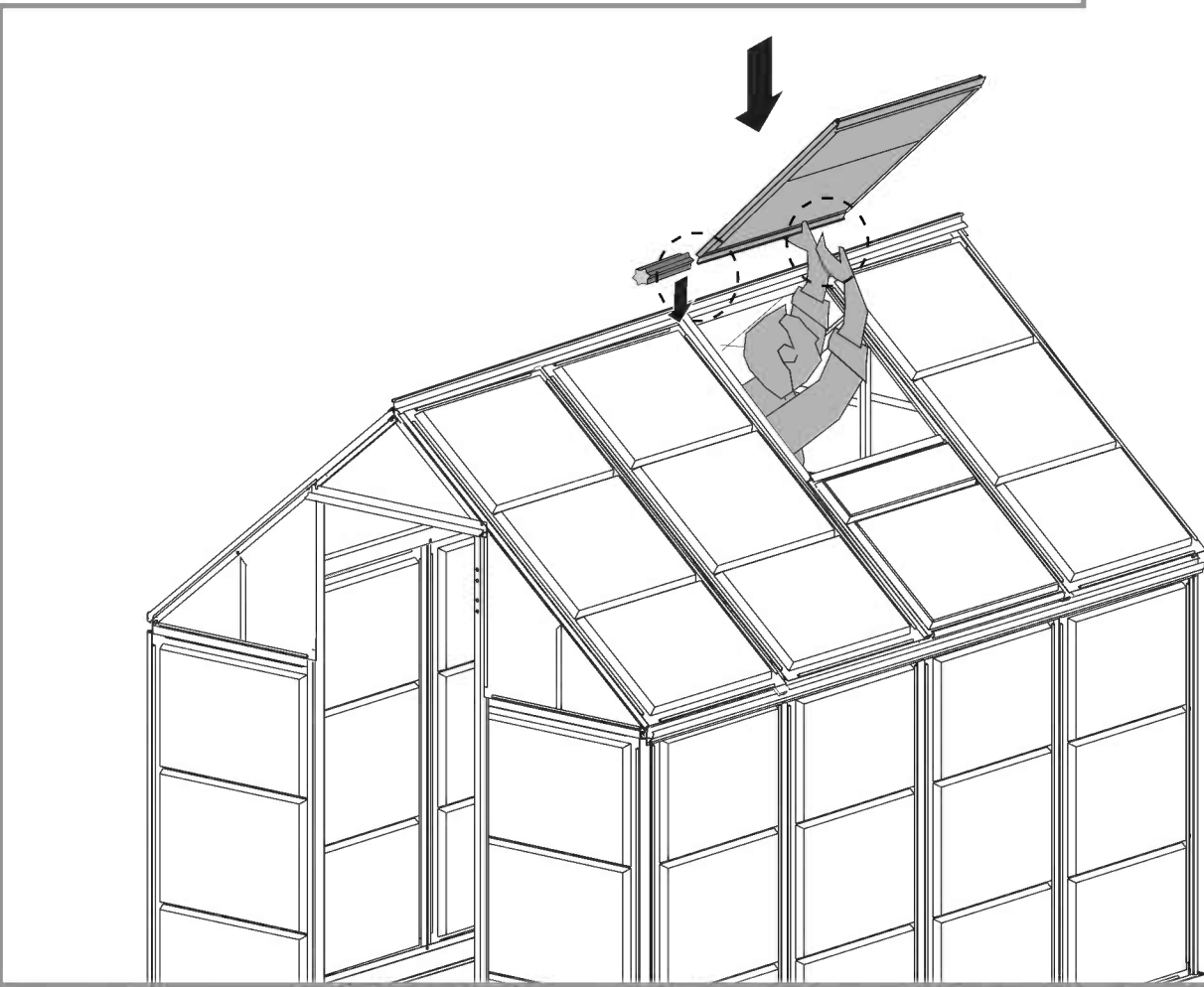

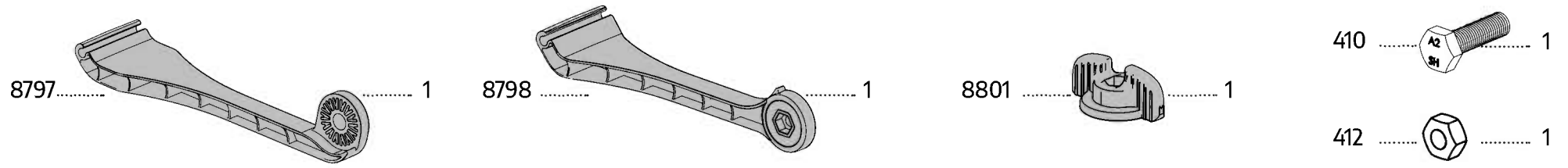
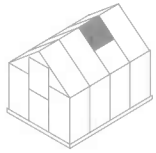

a

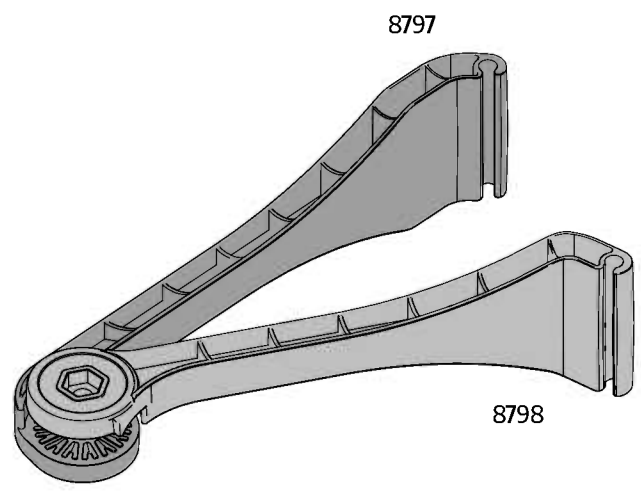

b

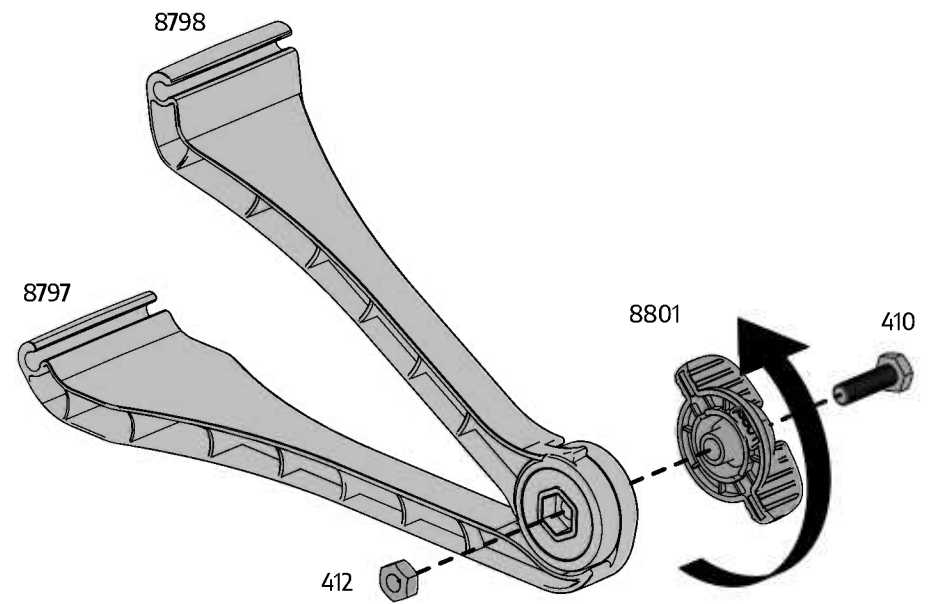

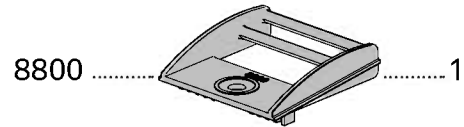
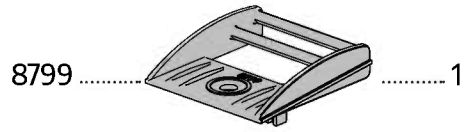
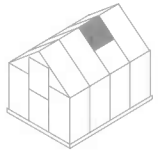

**a**

8799

8799

Warning icon: exclamation mark in a triangle.

**b**

8800

8800

Warning icon: exclamation mark in a triangle.



In case the window is not closed properly, please go to **Step 42**, release the screws, adjust the profile and tighten the screws.

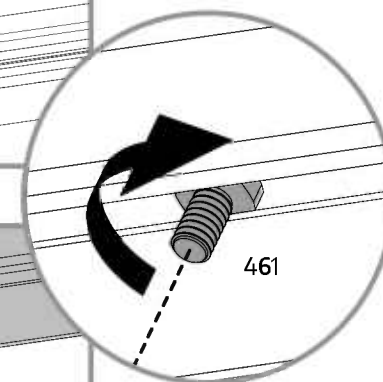
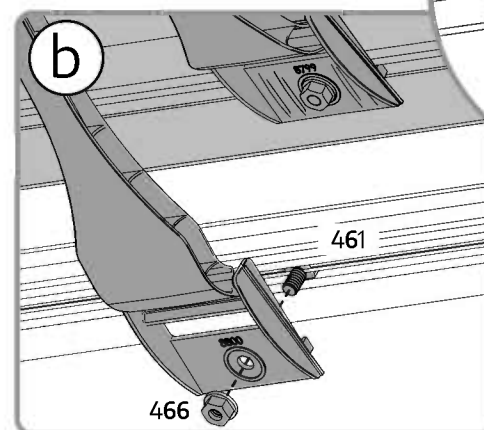
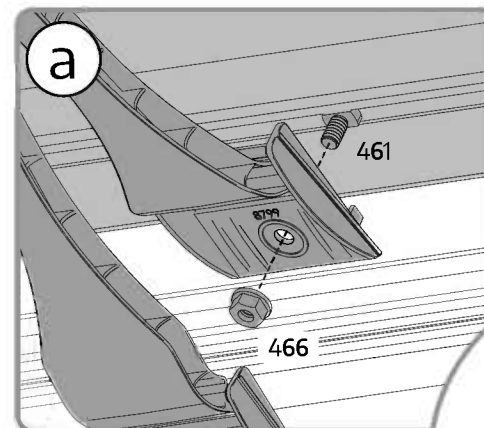
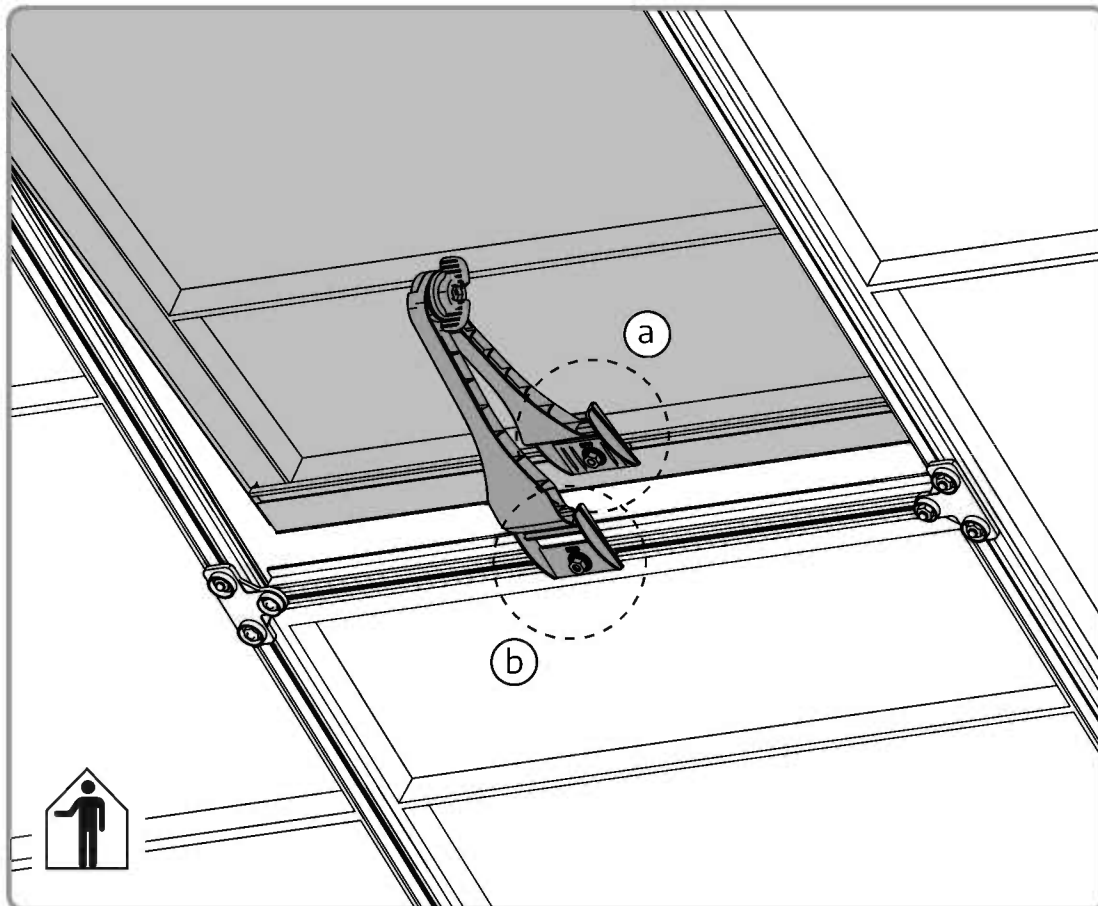
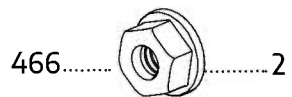
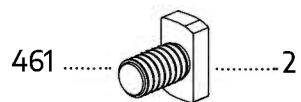
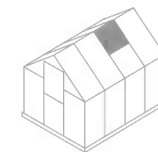



Determines door direction door post #7311 is where door hinges will be located **(Step 14)**.

Door assembly should be done according to this decision.

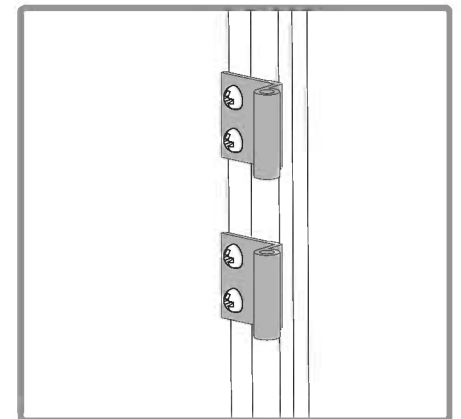
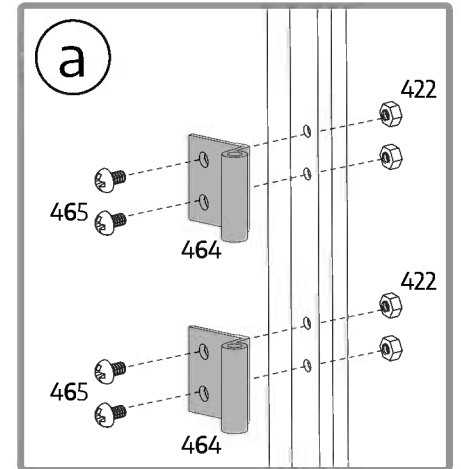
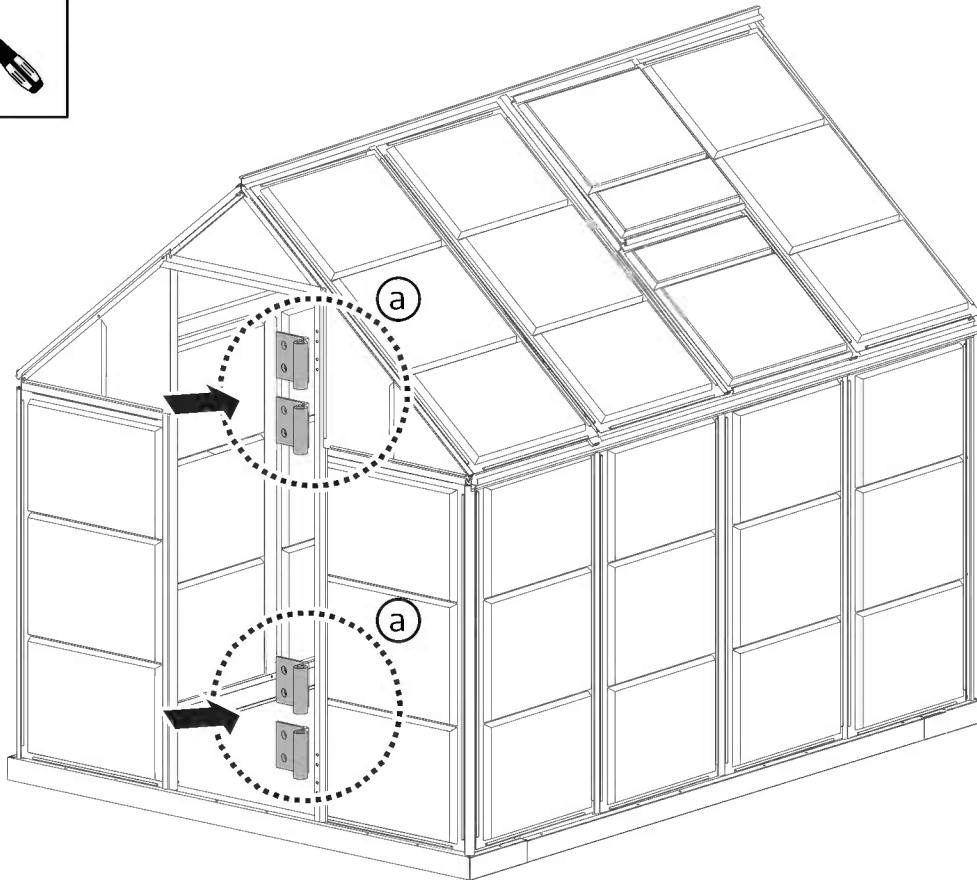
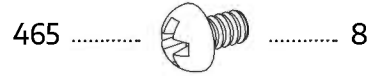
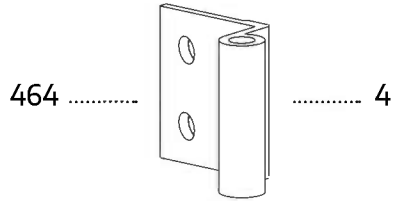
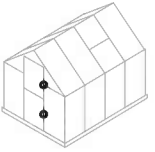



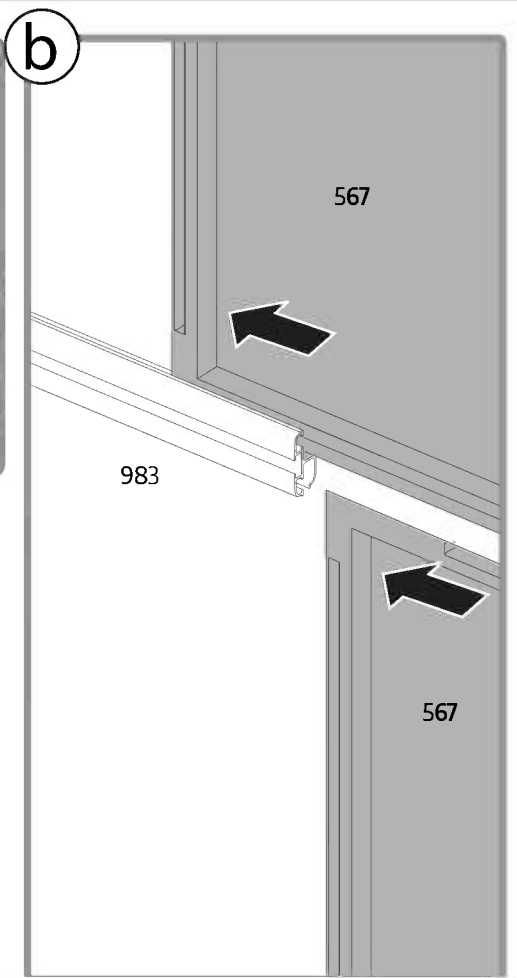
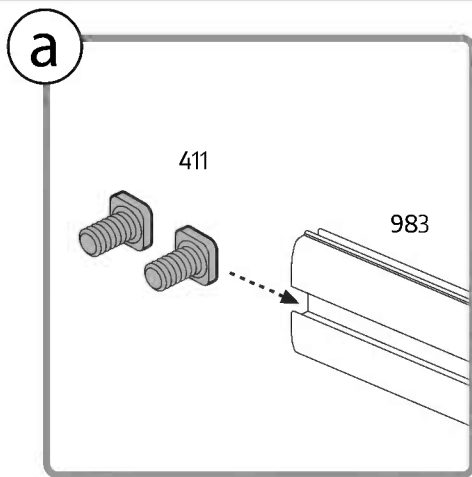
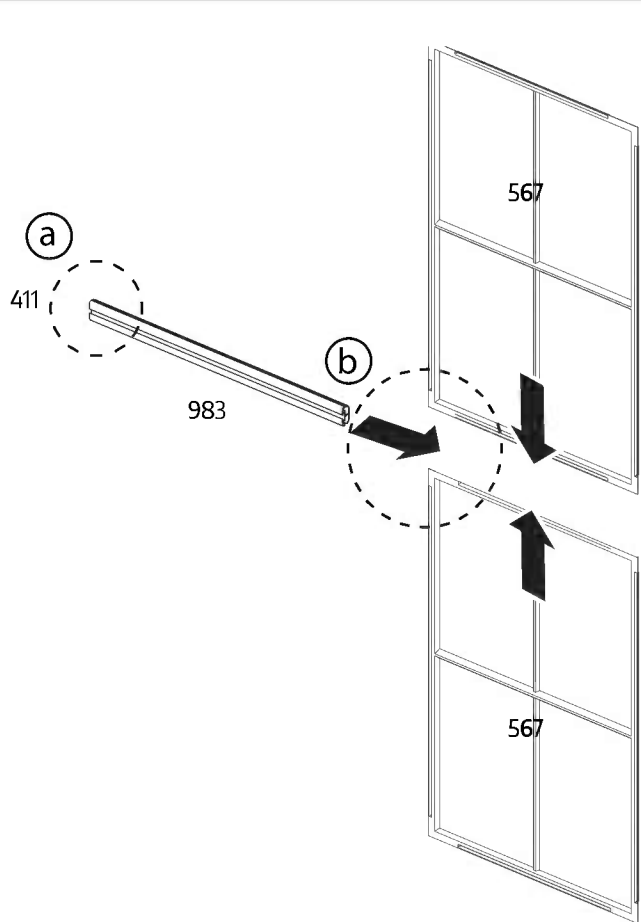
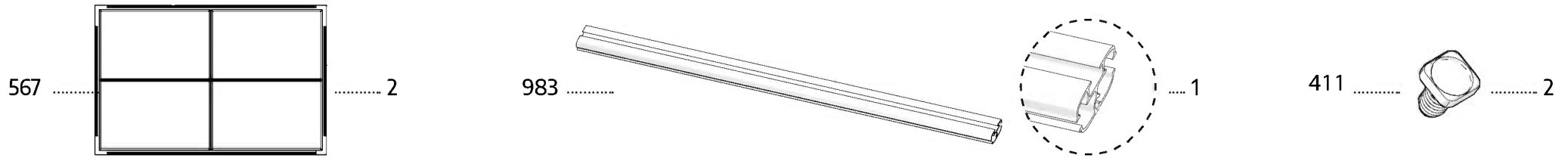
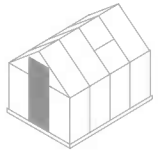

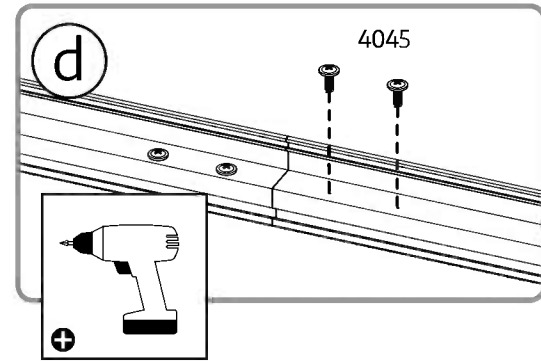
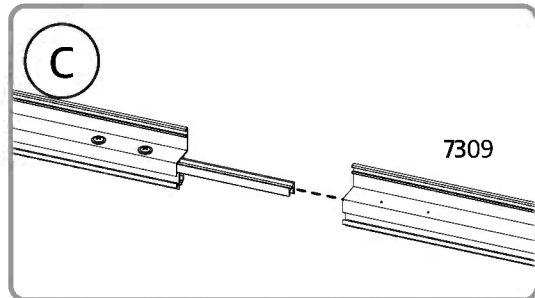
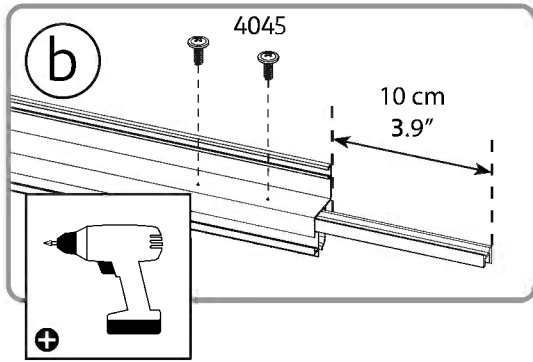
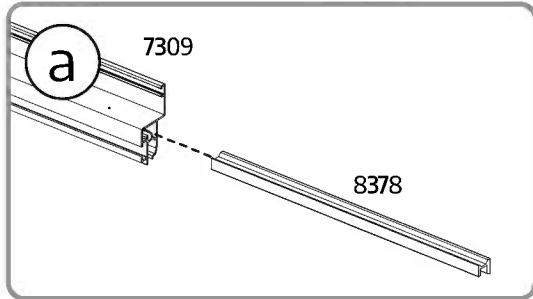
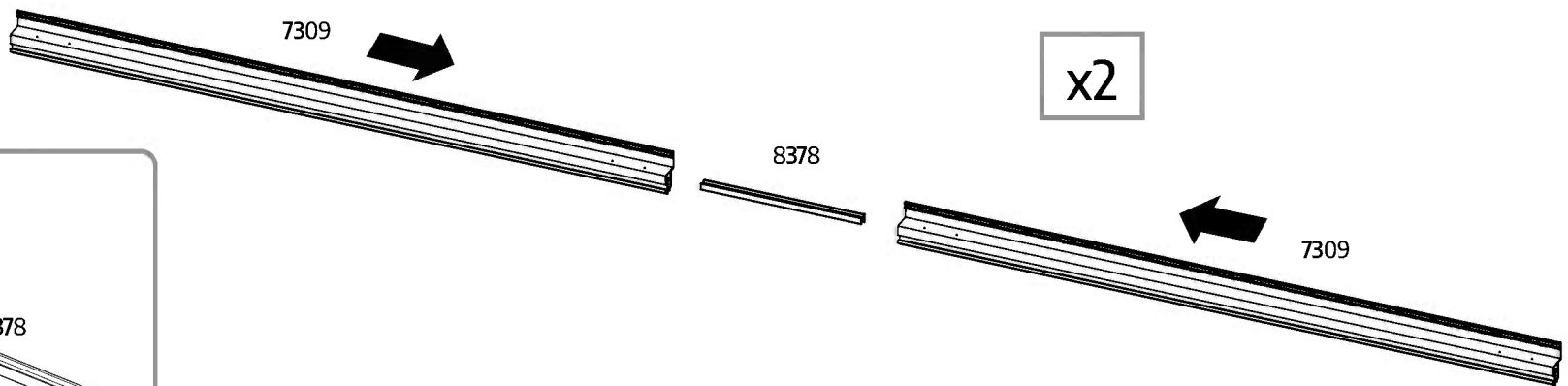
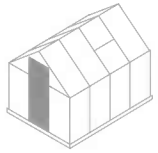

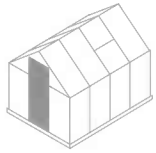

984 .....



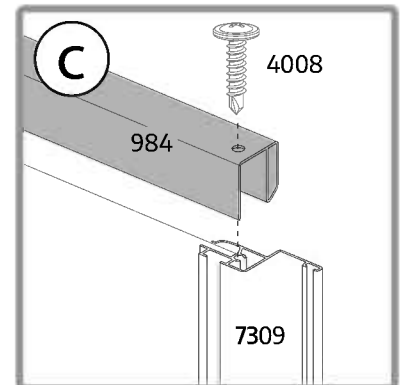
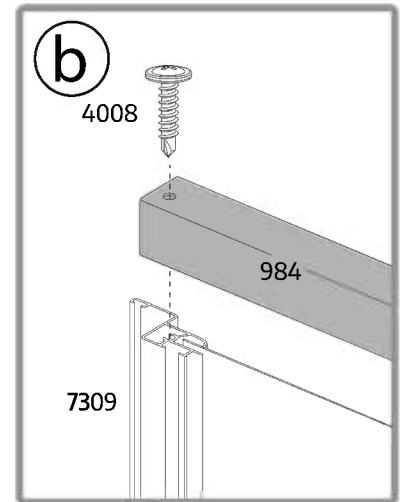
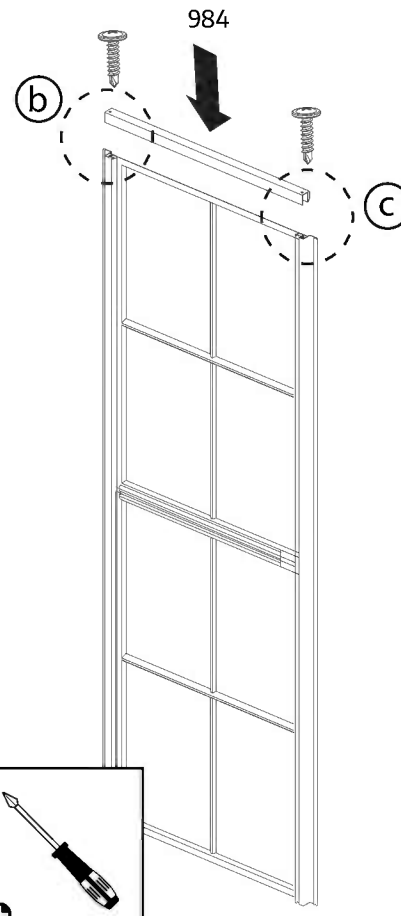
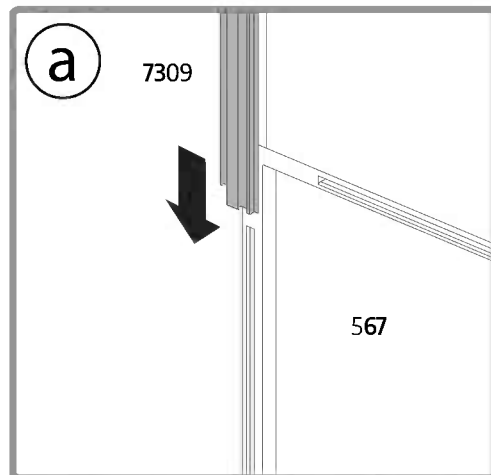
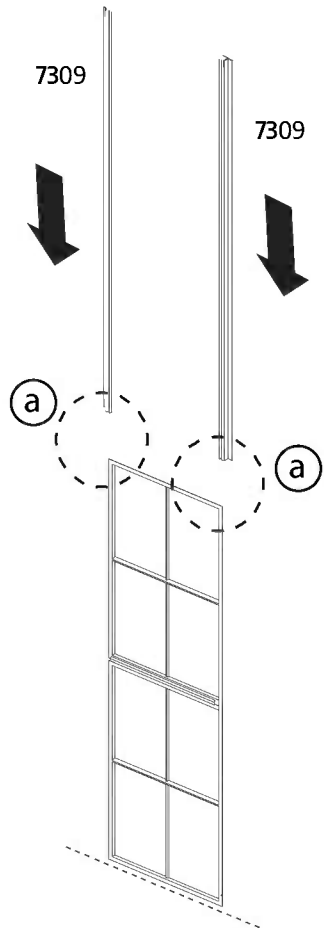
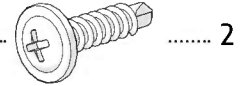

4008 .....



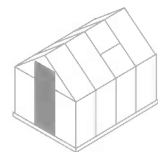

Determines door direction door post #7311 is where door hinges will be located **(Step 14)**.  
Door assembly should be done according to this decision.



- 411 .....  ..... 7
- 3016.....  ..... 1

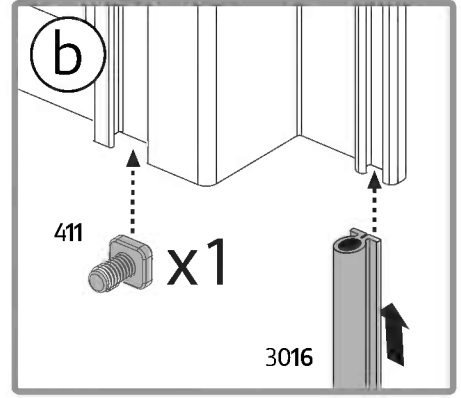
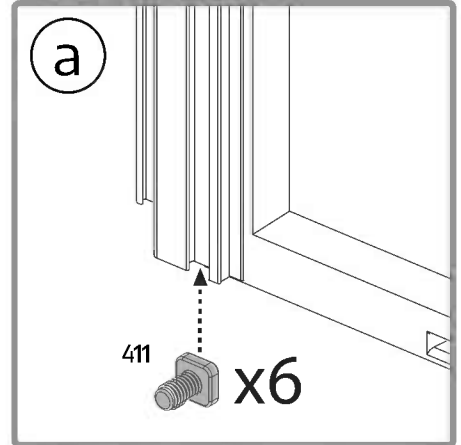
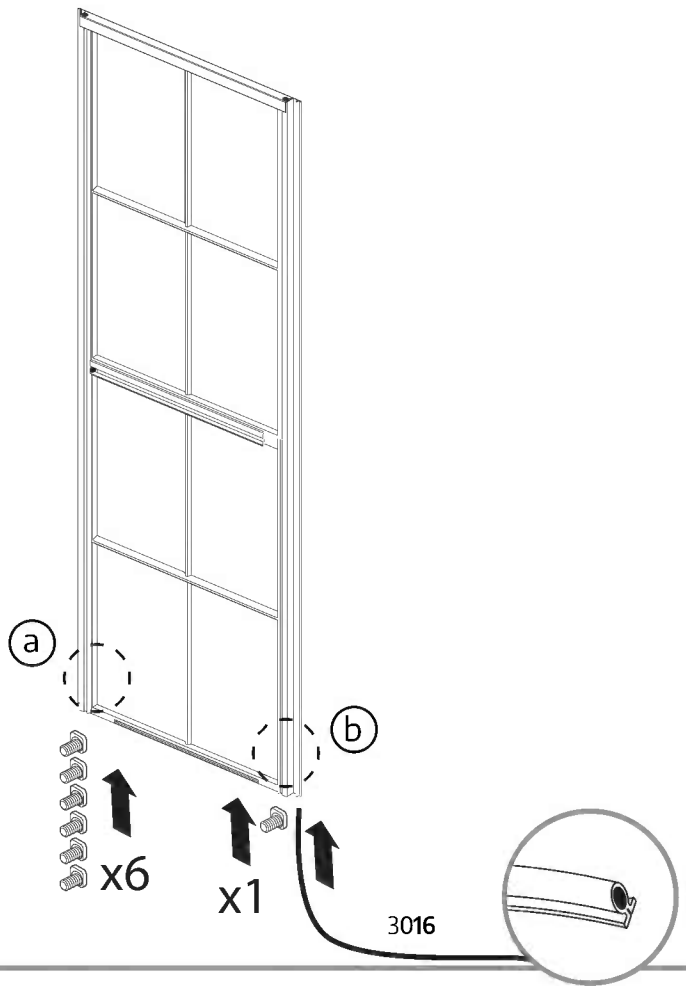



Determines door direction door post #7311 is where door hinges will be located **(Step 14)**.

Door assembly should be done according to this decision.

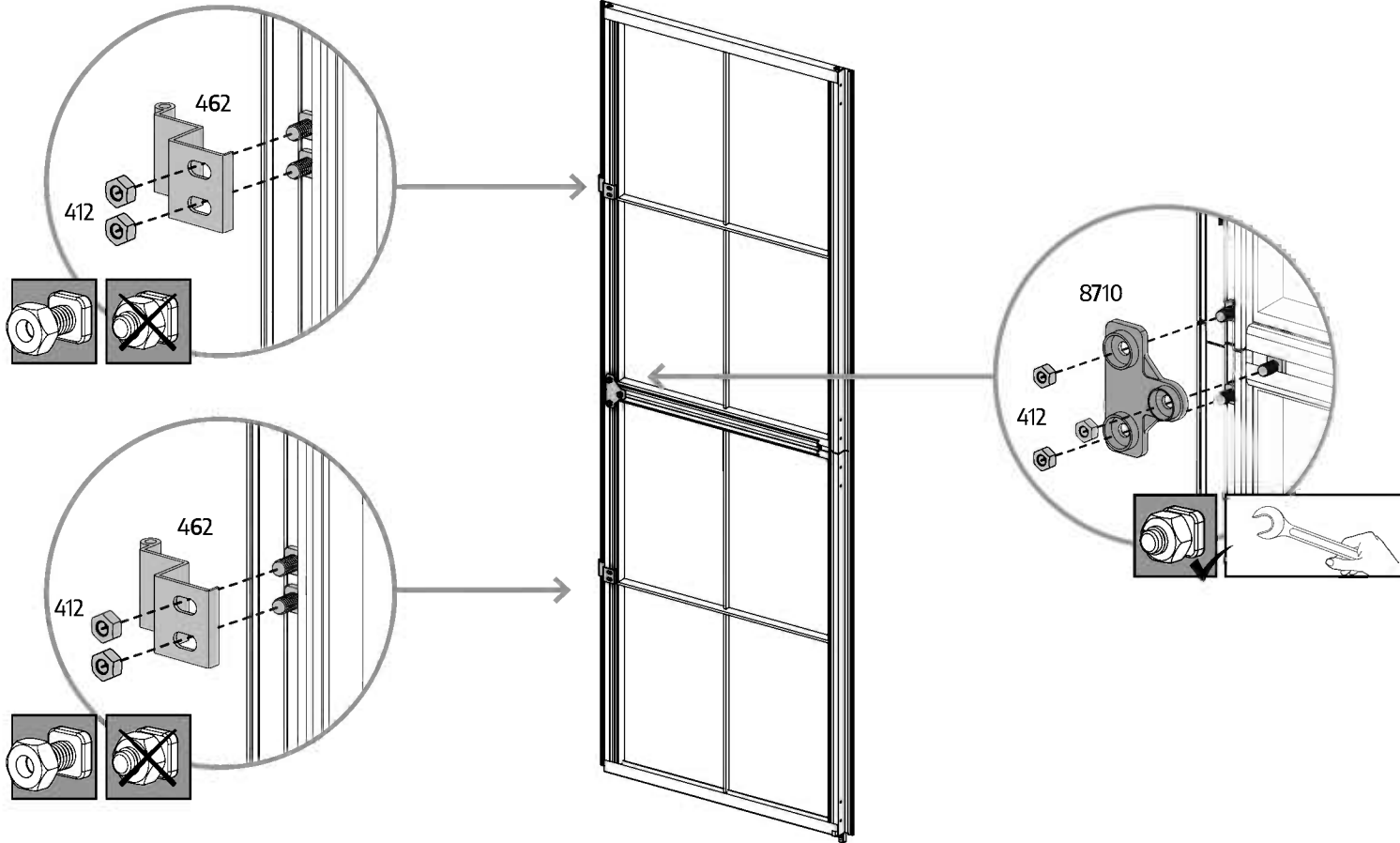
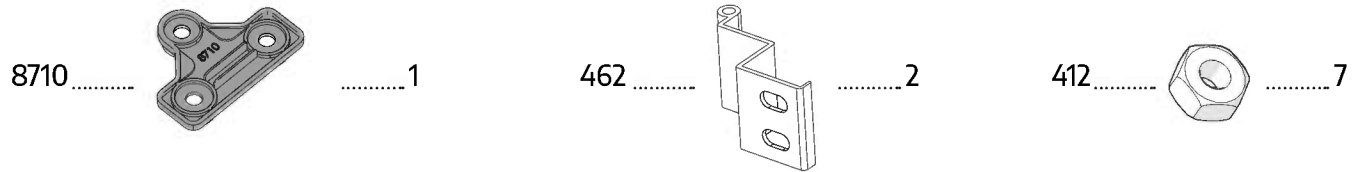
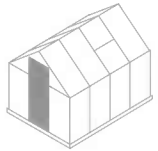



Determines door direction door post #7311 is where door hinges will be located **(Step 14)**.

Door assembly should be done according to this decision.

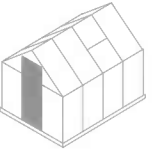

984 ..... 1

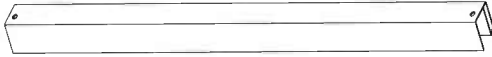

4037 ..... 1

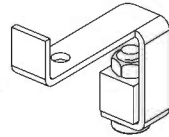

4008 ..... 2

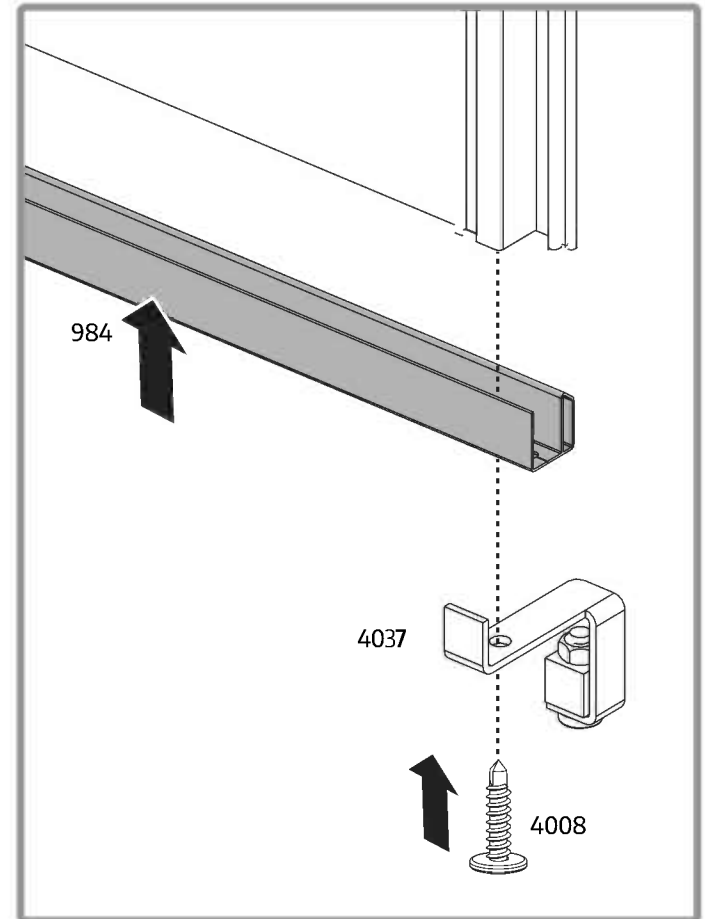
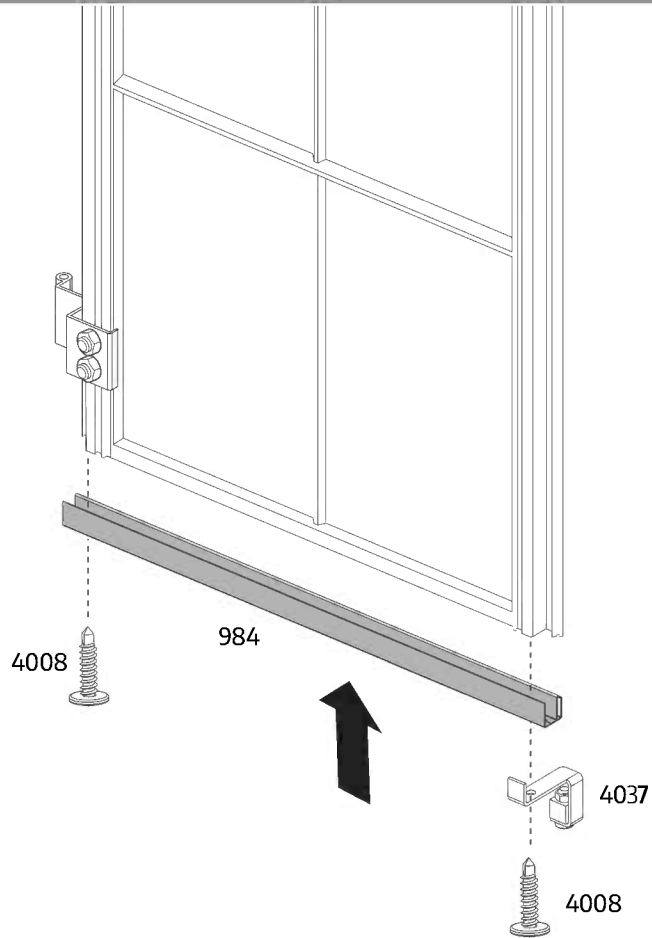
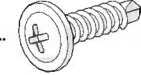



Determines door direction door post #7311 is where door hinges will be located **(Step 14)**.

Door assembly should be done according to this decision.

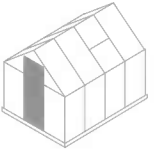

7086 ..... 1

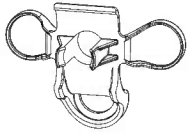

7085 ..... 1

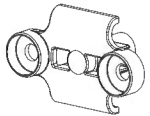

7084 ..... 1

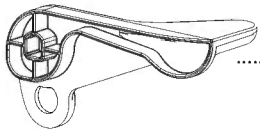

7083 ..... 1

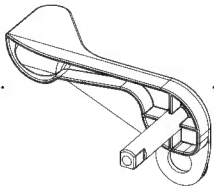

7088 ..... 1



M4 x 50 mm

423 ..... 1



412 ..... 2

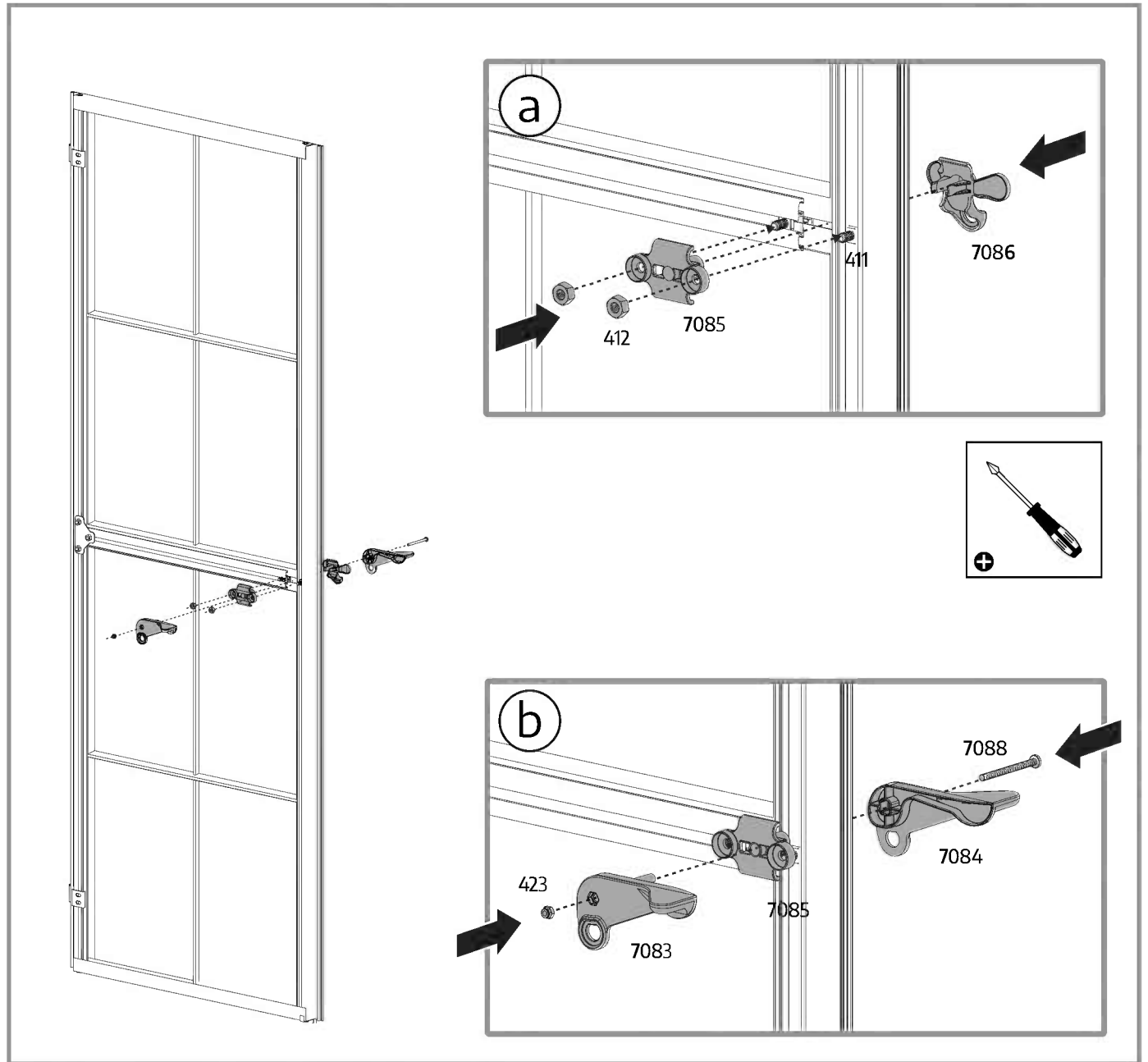



Determines door direction door post #7311 is where door hinges will be located **(Step 14)**.

Door assembly should be done according to this decision.

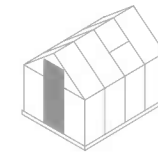

463 .....  ..... 2

180°

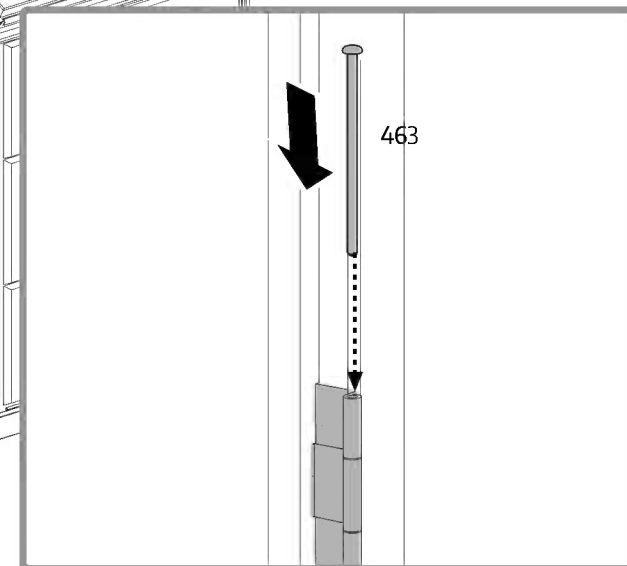
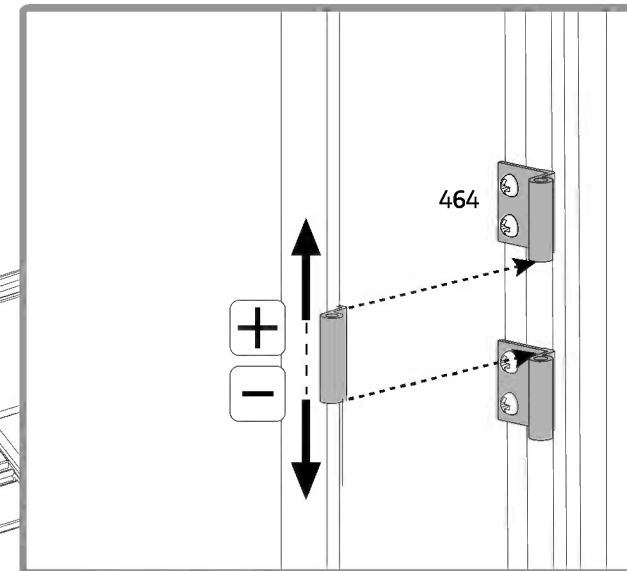
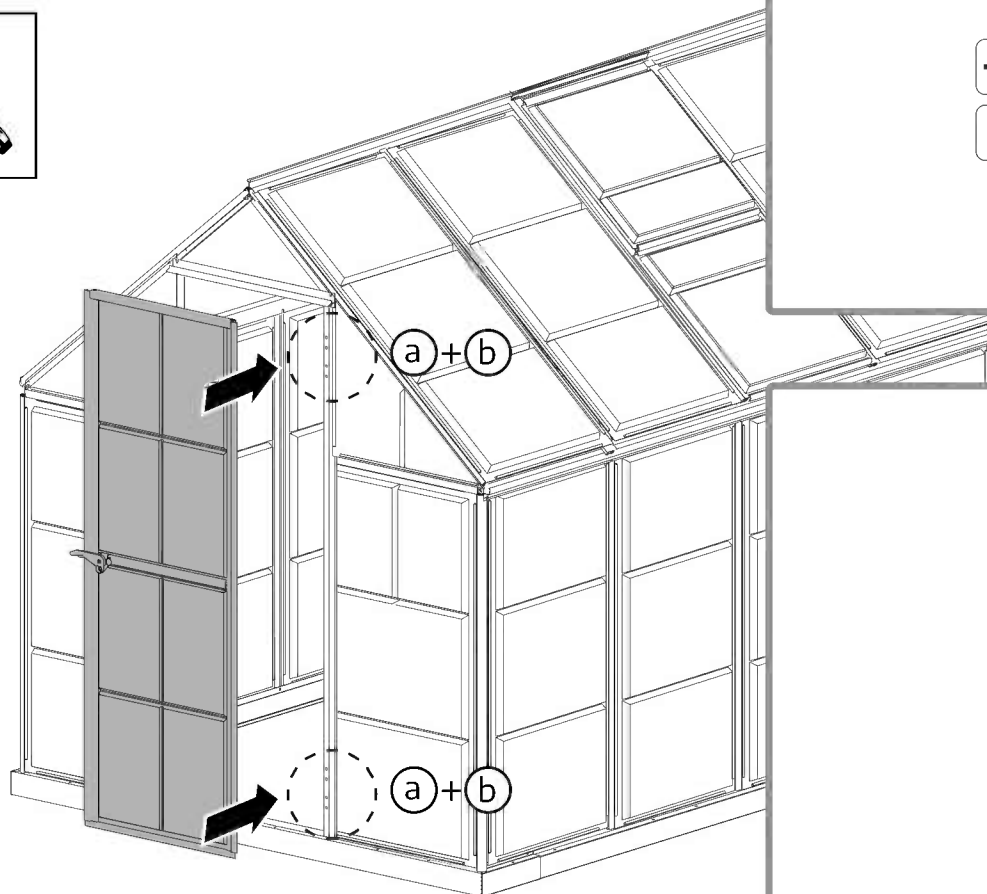
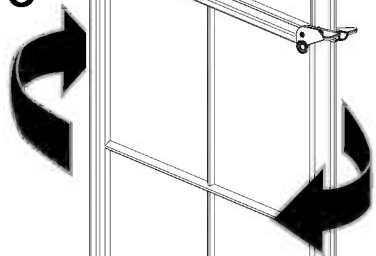



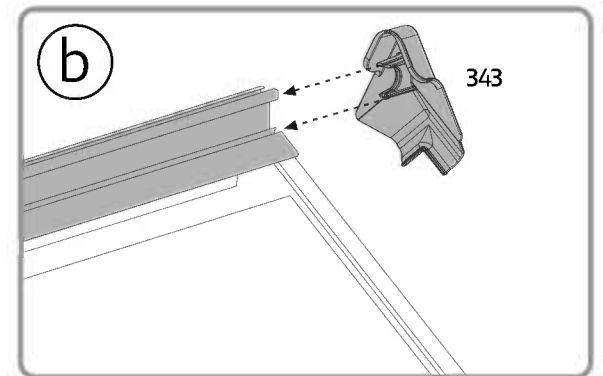
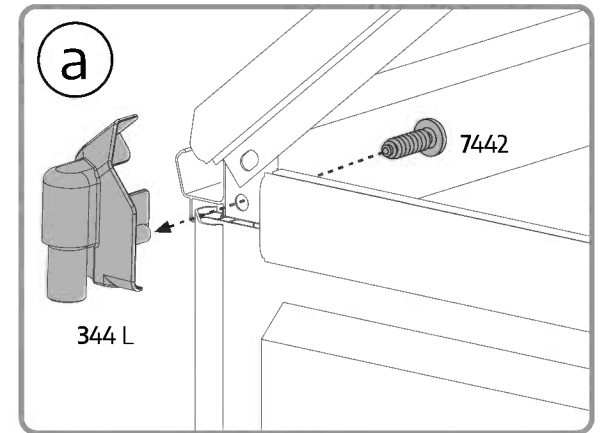
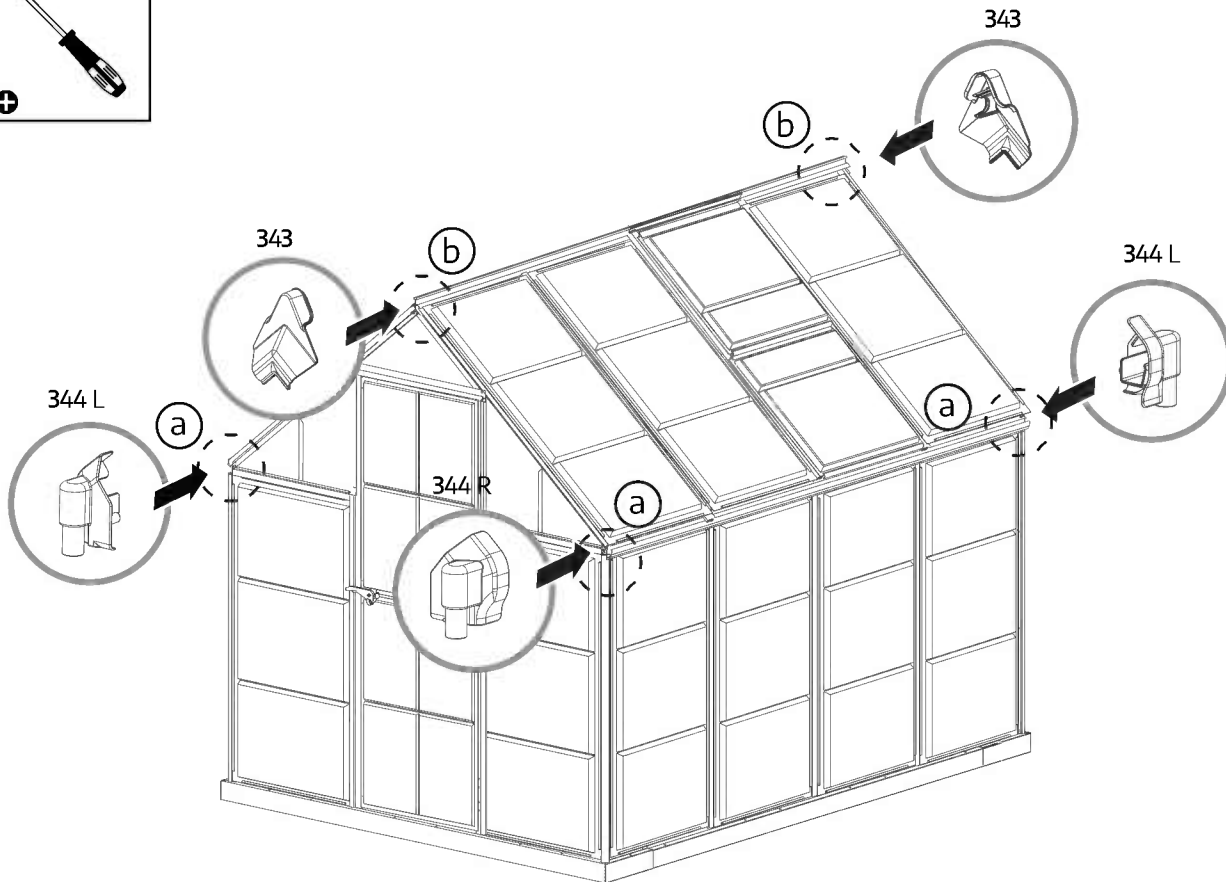
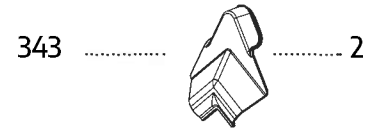
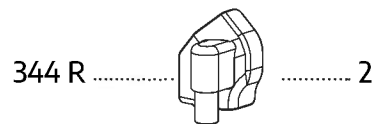
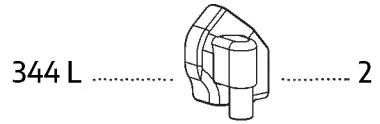
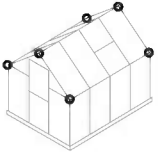



# HOW TO ASSEMBLE

## HEAVY DUTY SHELF KIT™

### IMPORTANT!

Please read these instructions carefully before starting assembly.  
Keep these instructions in a safe place for future reference.

[www.canopia.com](http://www.canopia.com)



A member of  
Palram Industries Ltd.

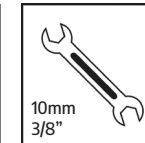
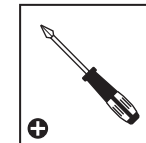
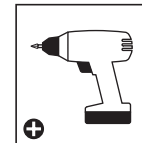
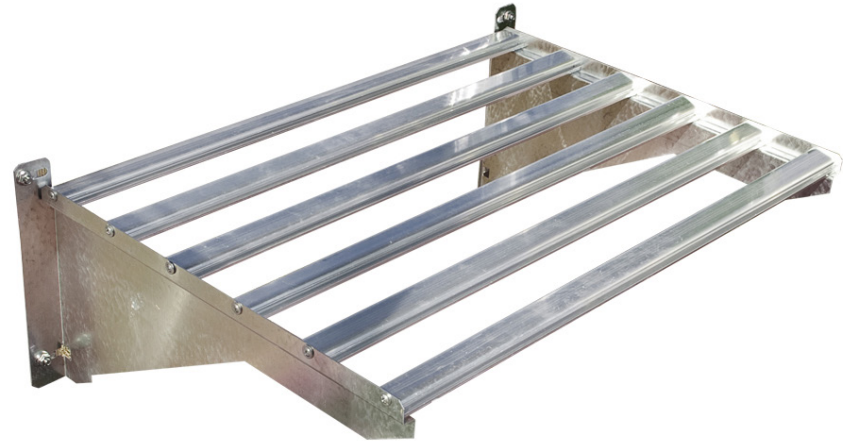

83163\_2112\_MV-2

# Contents

Item	Qty.	Item	Qty.
7048	6	4008	12 (+1)
7046	1	461	4 (+1)
7047	1	466	4 (+1)
		70	3

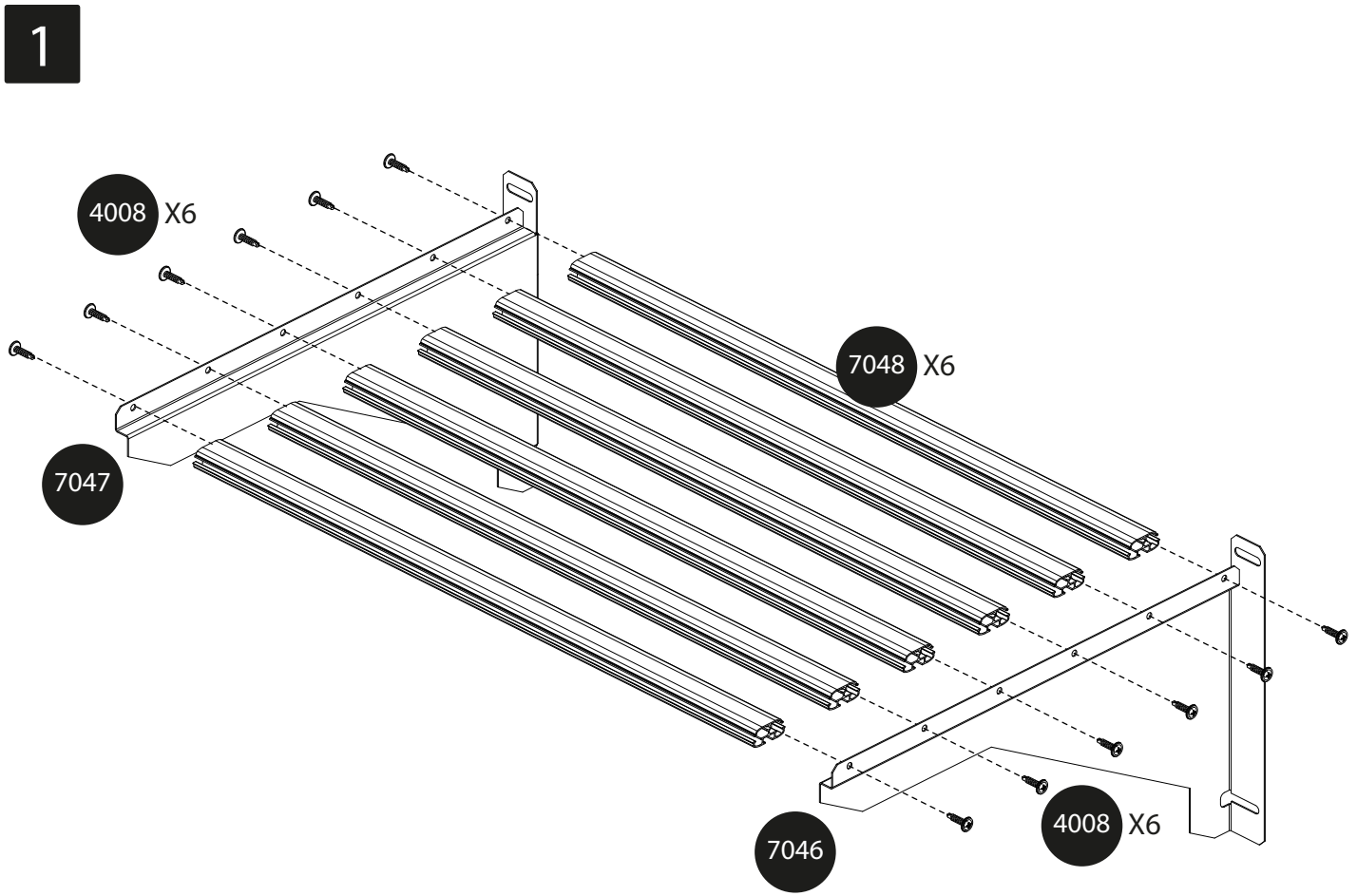

2

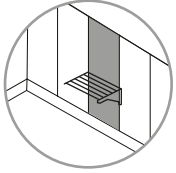

Middle

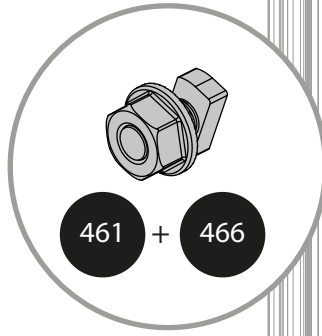

461 + 466

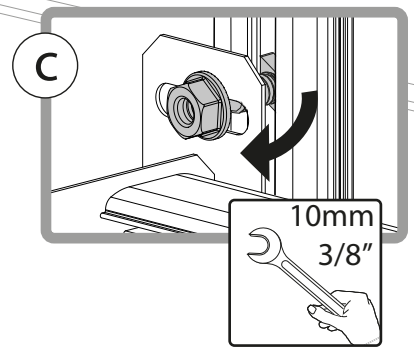
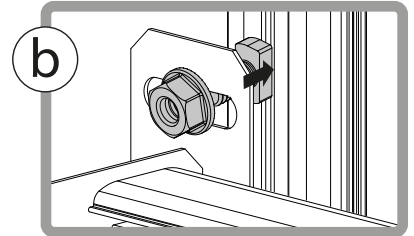
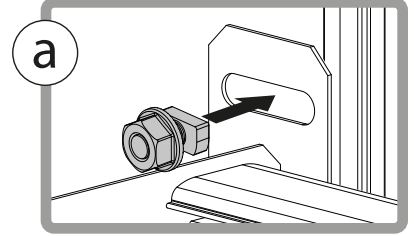

10mm  
3/8"

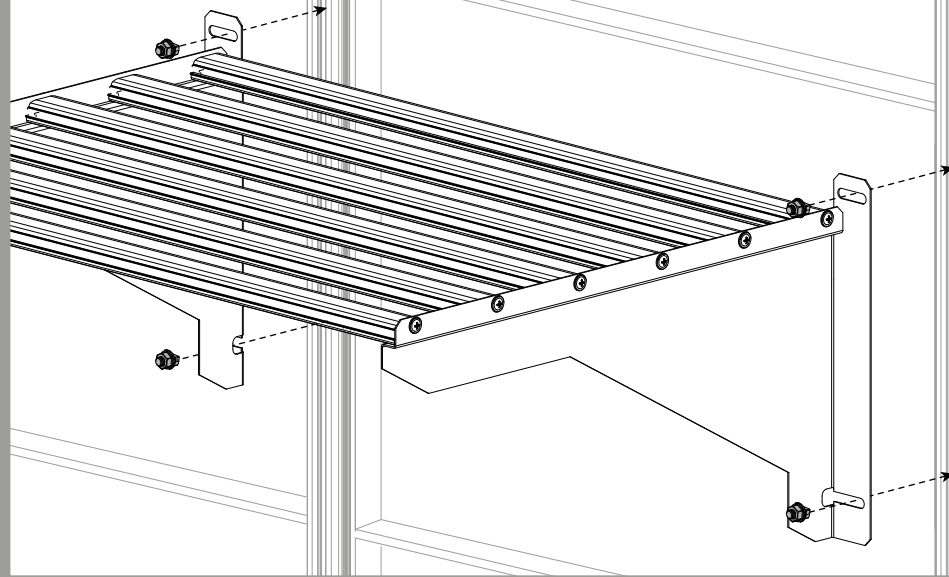

3

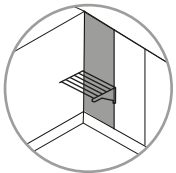

Corner

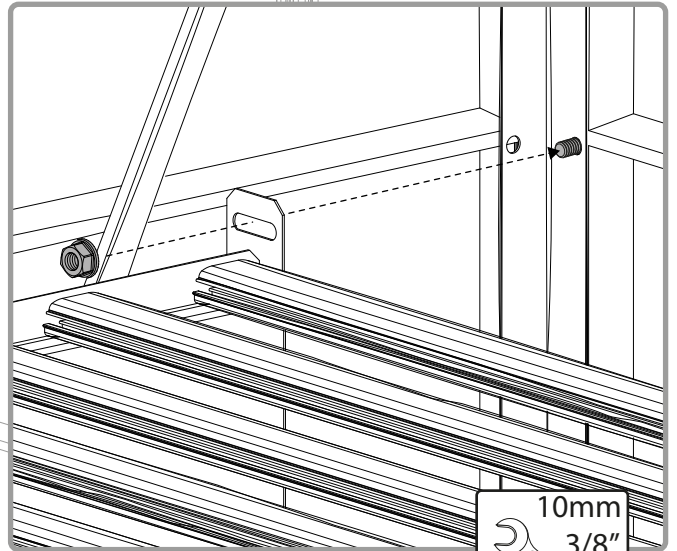

10mm  
3/8"

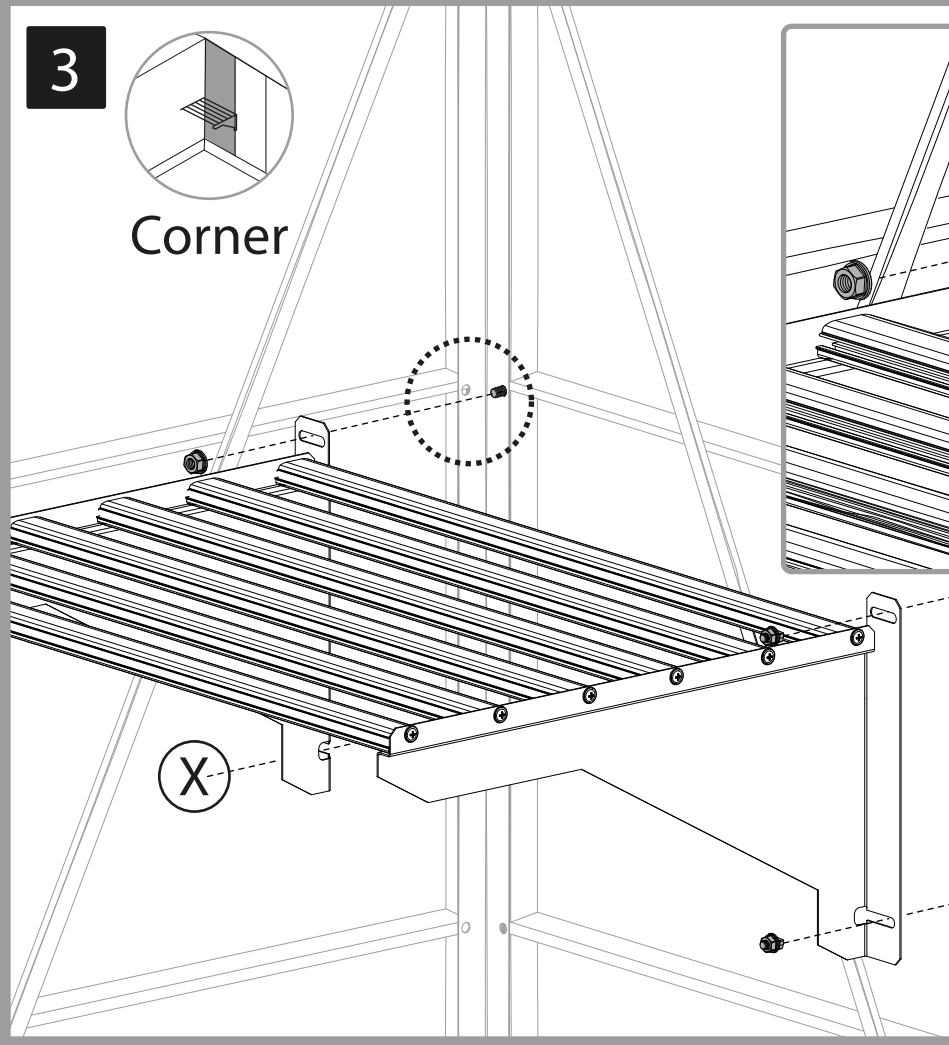

4

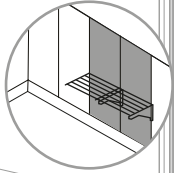

2 sets

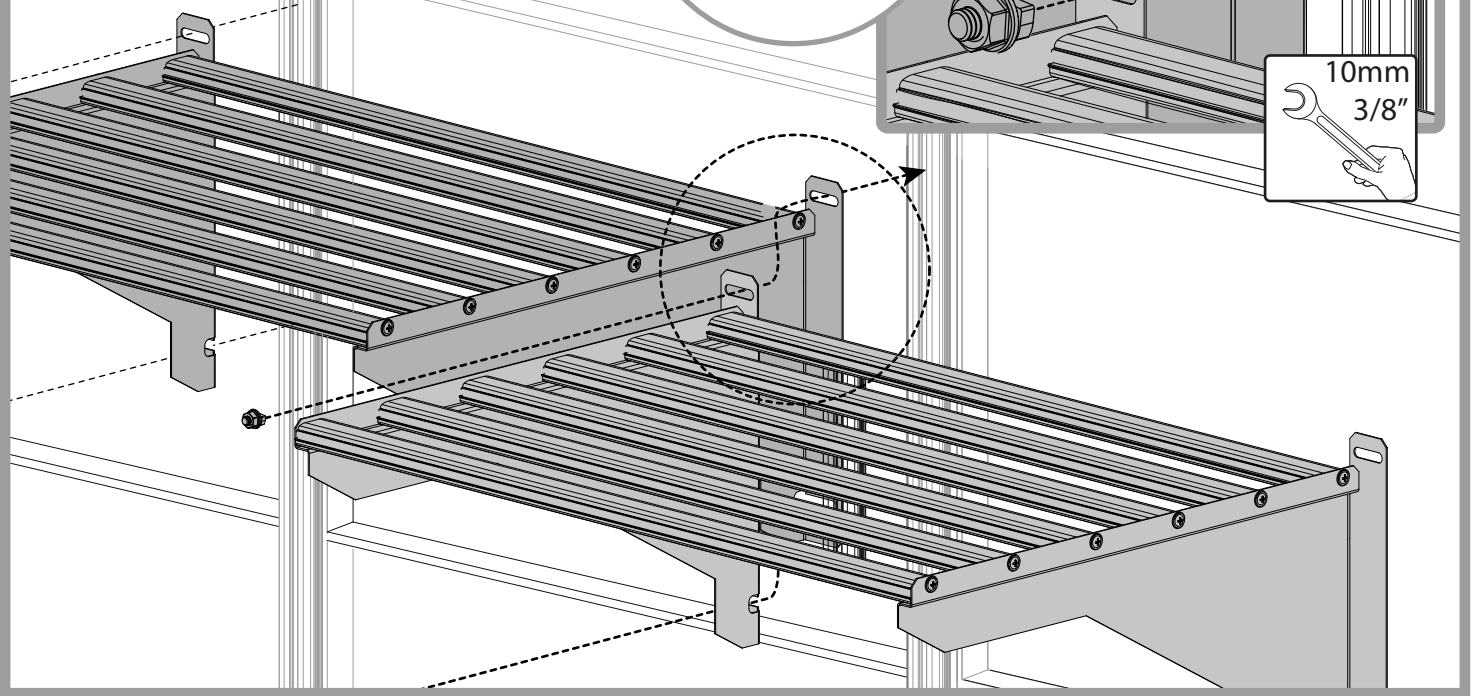
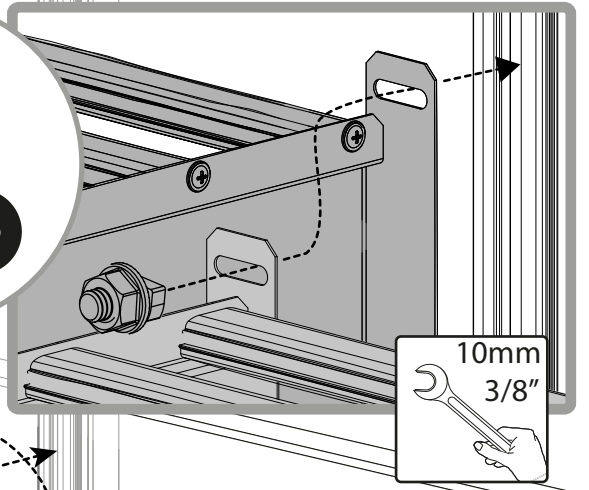
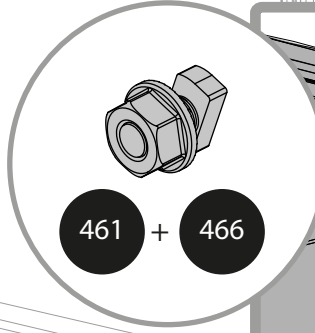

5

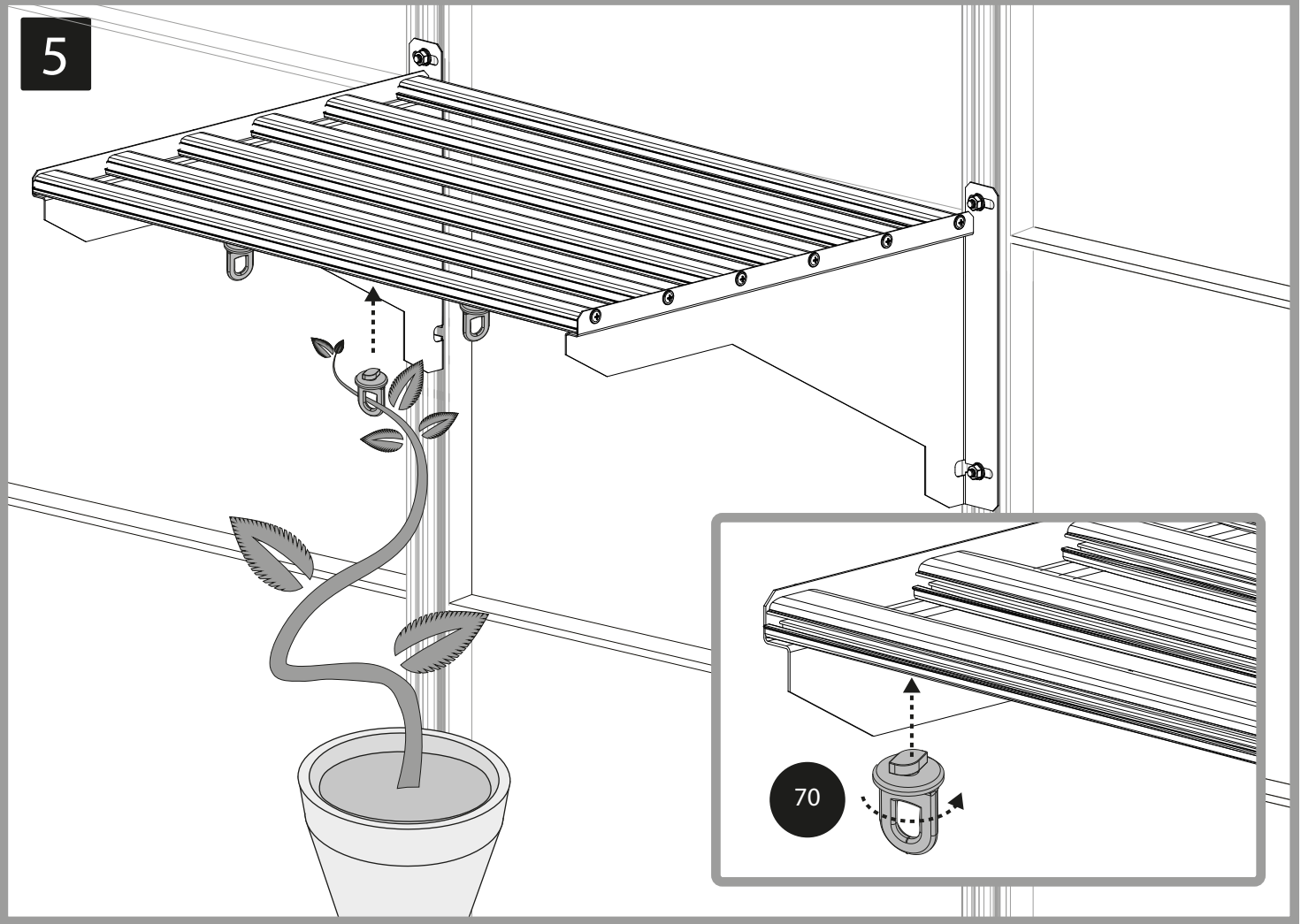

70

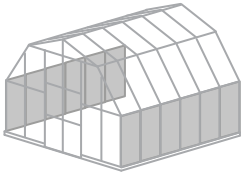

6

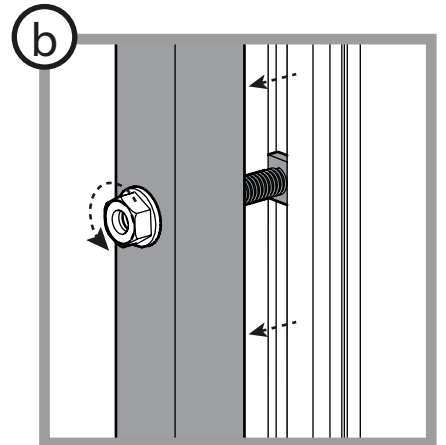
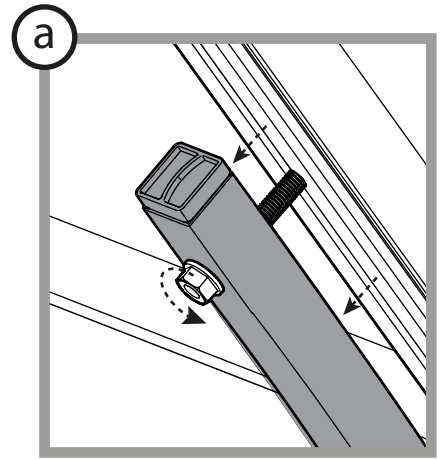
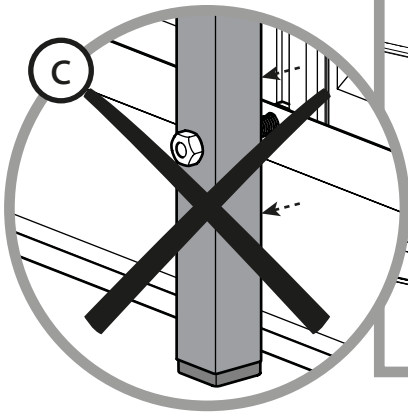
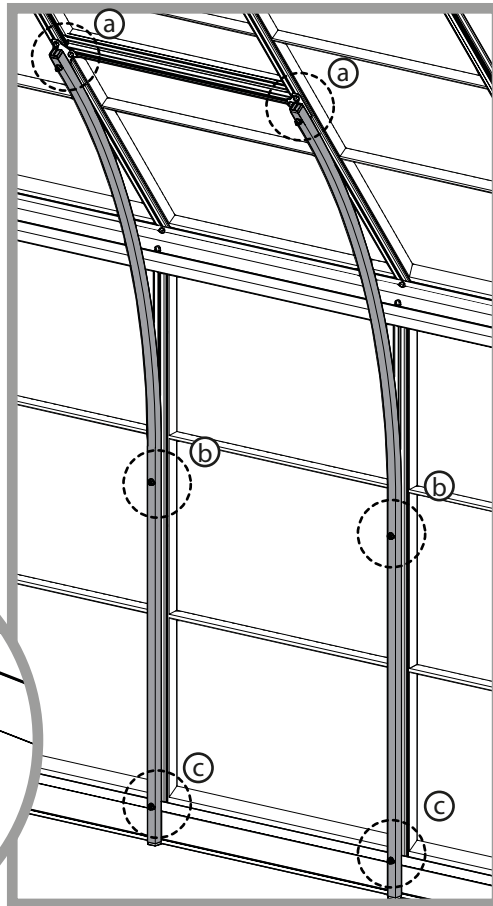

7

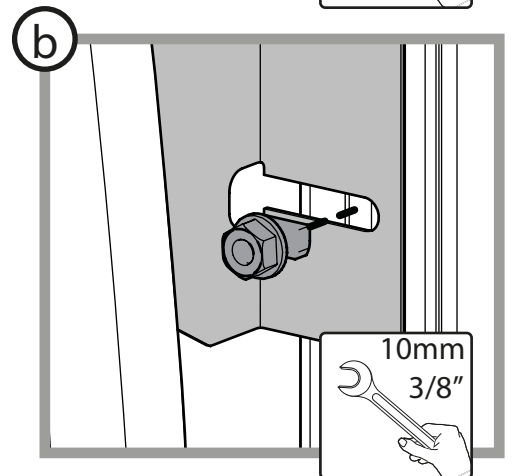
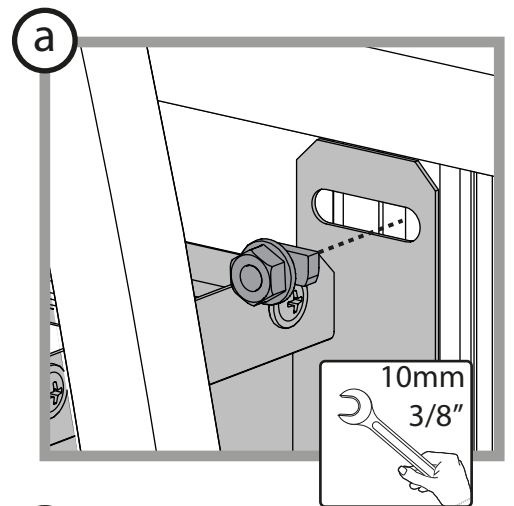
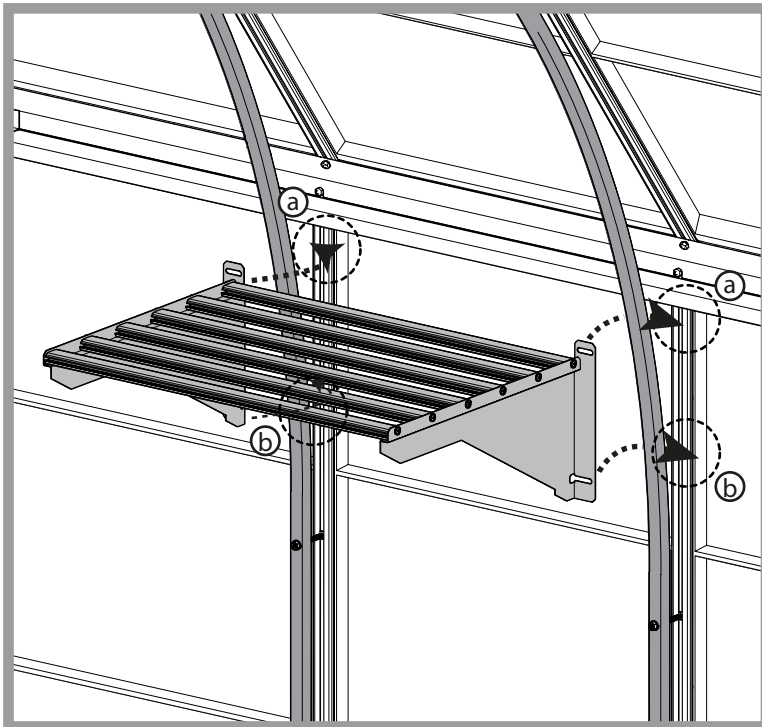

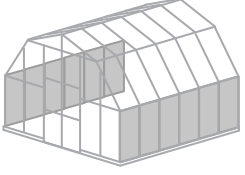

8

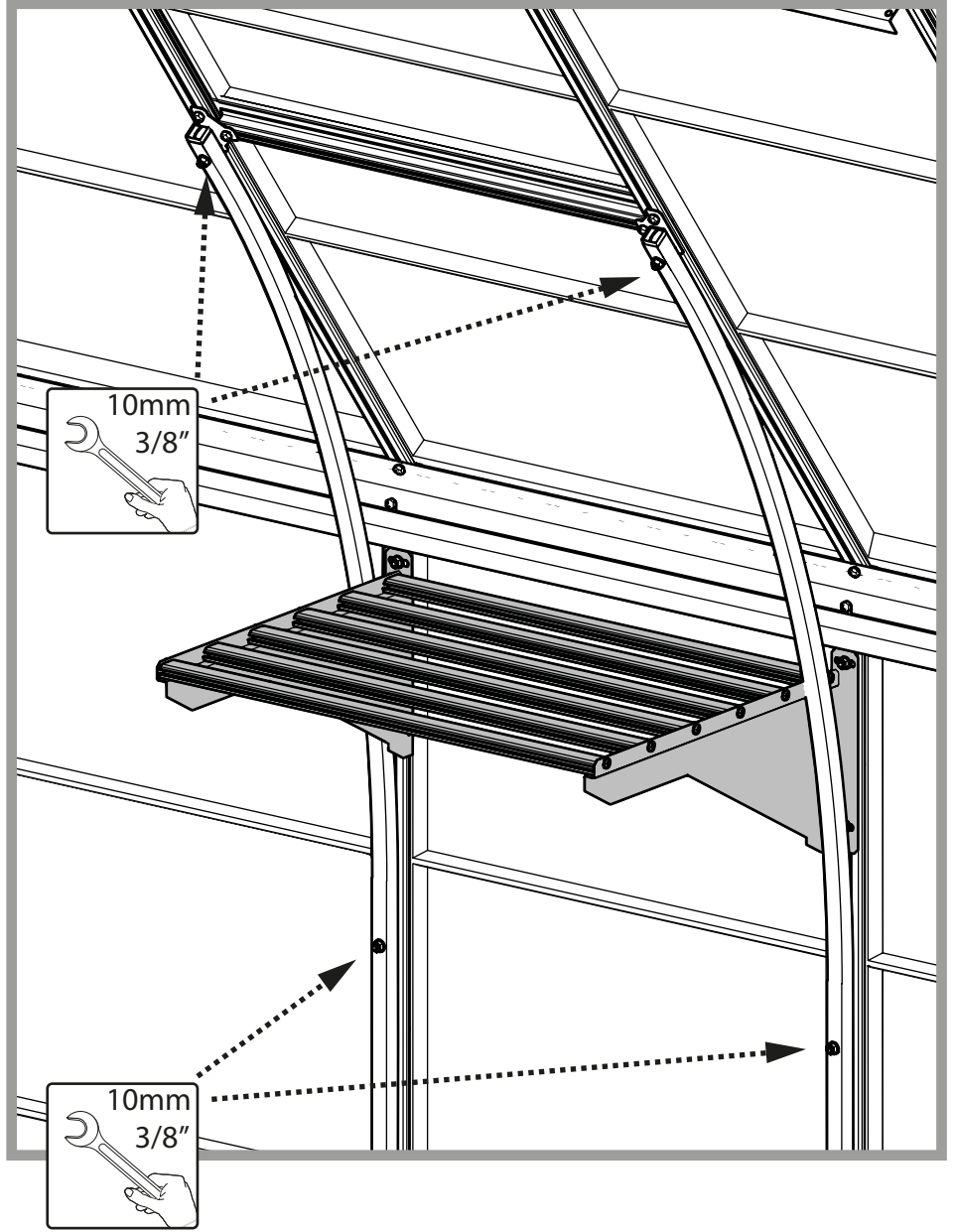



# HOW TO ASSEMBLE

## AUTOMATIC VENT OPENER™

Suitable for Palram - Canopia Greenhouses with pre-assembled Roof Vent

### IMPORTANT!

Please read these instructions carefully before starting assembly. Keep these instructions in a safe place for future reference.

[www.canopia.com](http://www.canopia.com)



A member of Palram Industries Ltd.

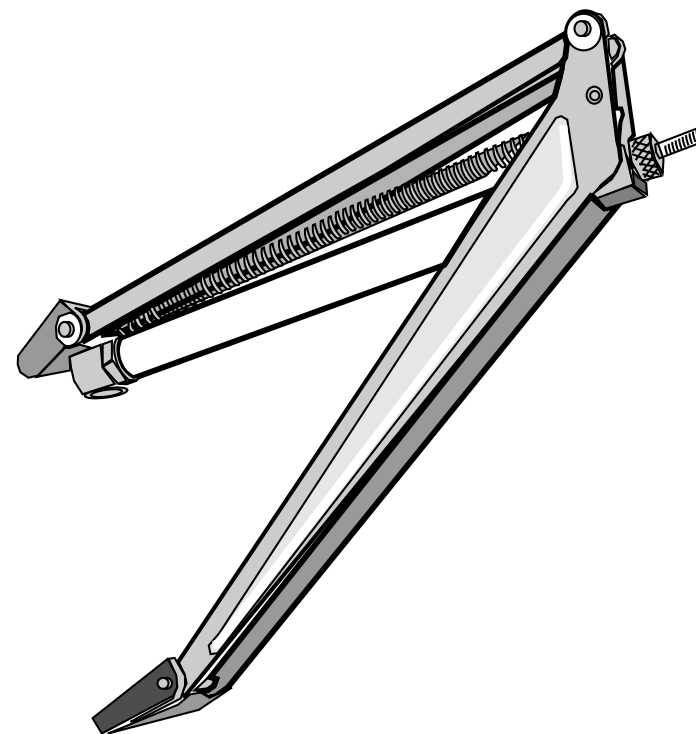

Vent	Length	Opening Temp Between	Max Vent Opening	Max Weight Lifted	Suitable For Window up to Size
XL	12" / 30cm	53.6° f & 59° f / 12° c & 15° c	12" / 30cm	14lb / 6kg	2ft² / 60cm



71266\_2112\_MV-5.2



## BEFORE ASSEMBLY

1. Please CAREFULLY READ ALL, instructions & remarks, BEFORE STARTING THE ASSEMBLY of the Automatic Vent Opener.
2. CARRY OUT the assembly steps IN THE ORDER SET OUT in the instructions.

## FITTING THE UNIT

- A manual vent opener, if already assembled, should be removed.
- Follow the next steps for fitting the unit according to the greenhouse model you have purchased.
- In the last step use the plastic-knurled adjuster to adjust closing gap.

## IMPORTANT INFORMATION

- Lubricate all moving parts after fitting and before each spring and autumn using light oil. Use grease or petroleum jelly for the piston rod.
- In case of snow accumulation during winter season and if you deploy a heating system inside your greenhouse, please remove the Automatic Vent Opener and switch to a manual opener.

## TOOLS & EQUIPMENT



Work Gloves



Philips Head Screwdriver



## IMPORTANT ASSEMBLY STEPS

### Preparing the unit for fitting

#### Step 1:

Prior to fitting the Automatic Vent Opener, the power tube has to be cooled by placing it in a refrigerator for approximately 30 minutes.

#### Step 2:

Place the cool steel piston rod against a hard surface and push it firmly back into the power-tube.

#### Step 3:

Lift the Automatic Vent Opener with one hand, and slip the threaded steel piston rod into the plastic knurled adjuster, which is fixed in the swiveling block.

#### Step 4:

The plastic-knurled adjuster will be used later to adjust the vent closing position.

## ANTES DEL MONTAJE

1. Por favor lea todas las notas, instrucciones y comentarios ANTES DE COMENZAR A ARMAR el Automatic Vent Opener.
2. LLEVE A CABO el armado EN EL ORDEN ESTABLECIDO en las instrucciones.

## INSTALANDO LA UNIDAD

- Si ya existe un abridor de ventilación manual instalado, debe ser removido.
- Siga los pasos para la instalación de la unidad según el modelo de invernadero adquirido.
- En el último paso use el regulador moleteado en plástico para ajustar el espacio de cerrado.

## INFORMACIÓN IMPORTANTE

- Lubrique todas las piezas móviles después del montaje y antes de cada primavera y otoño con un aceite fluido. Use grasa o vaselina para el vástago del pistón.
- En caso de acumulación de nieve durante la estación de invierno y si despliega un sistema de calefacción dentro del invernadero, por favor, extraiga el abridor de ventilación automática y reemplácelo por un abridor manual.

## HERRAMIENTAS Y EQUIPOS



Guantes de trabajo



Destornillador de cabeza Philips



## PRINCIPALES ÉTAPES D'ASSEMBLAGE

### Preparando la unidad para la instalación

#### Paso 1:

Antes de instalar el Automatic Vent Opener, el tubo de poder debe ser enfriado, para esto ubíquelo en el refrigerador por 30 minutos aproximadamente.

#### Paso 2:

Ubique la biela de acero enfriada frente a una superficie dura y presiónela firmemente de vuelta al interior del tubo de poder.

#### Paso 3:

Levante el brazo del Automatic Vent Opener con una mano, y deslice la biela roscada de acero hacia el interior del regulador moleteado en plástico, el que se instala en el bloque rotatorio.

#### Paso 4:

El regulador moleteado en plástico se usará más adelante para ajustar la posición de cerrado de la ventilación.

# Automatic Vent Opener Assembly Instructions for: **SNAP & GROW** Greenhouses

## Contents

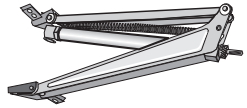

x1



4008 x5

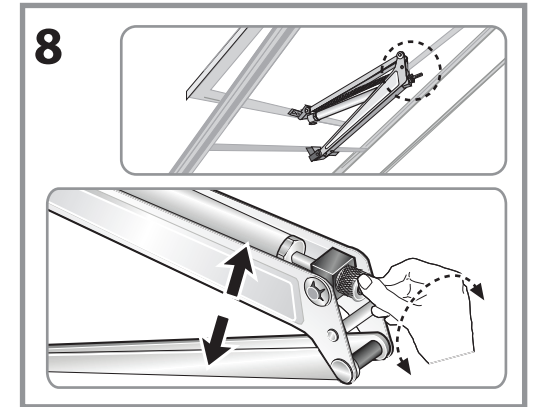
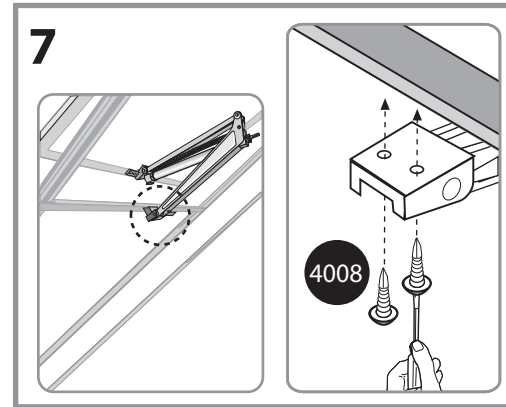
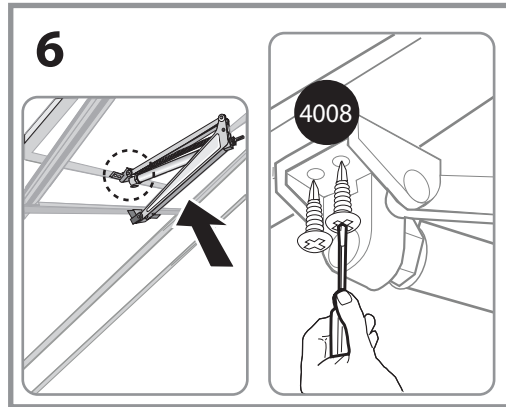
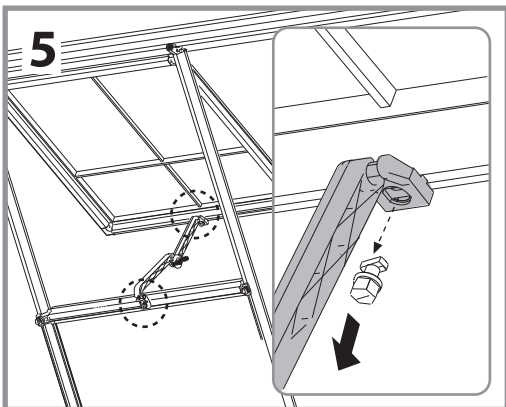
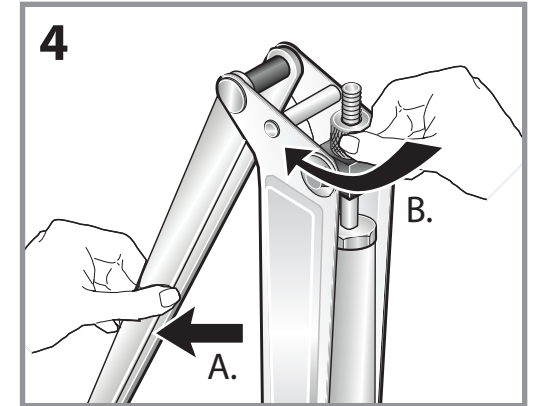
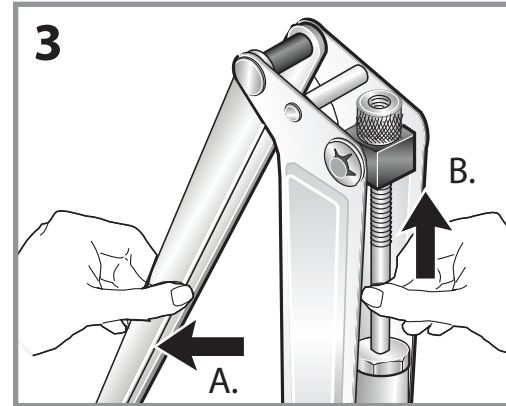
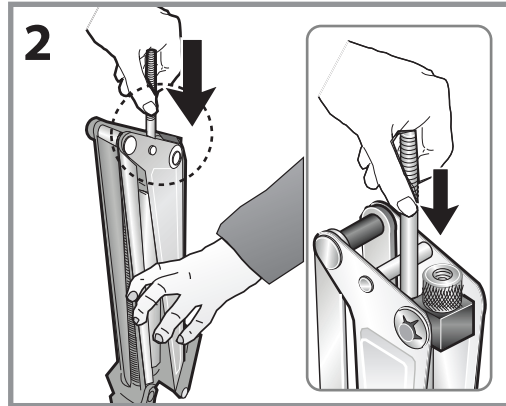
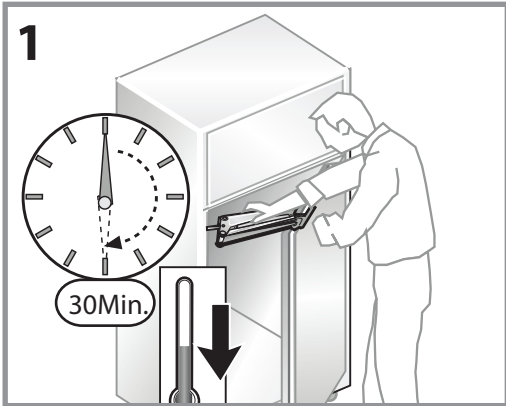

# Automatic Vent Opener Assembly Instructions for:

## Harmony, Hybrid, Mythos, Octave, Balance, Essence, Americana, Victory, Glory, Bella & Lean To Grow House 8x4

### Silver Line, Inter Line, Multi Line Greenhouses

#### Contents

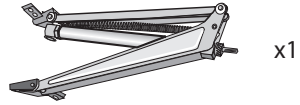

x1



422 x5



465 x5



461 x5



466 x5



964 x2

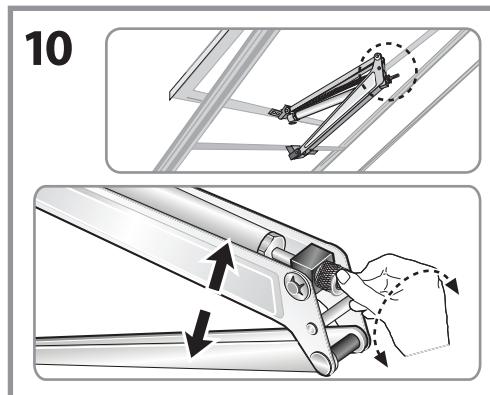
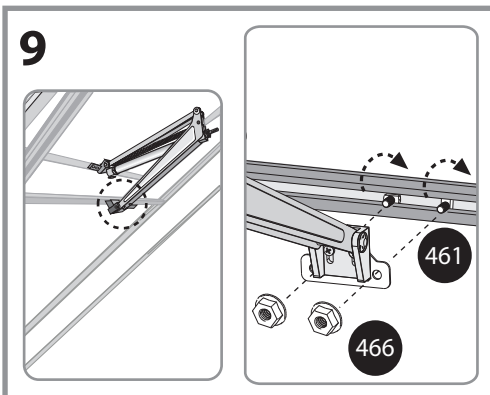
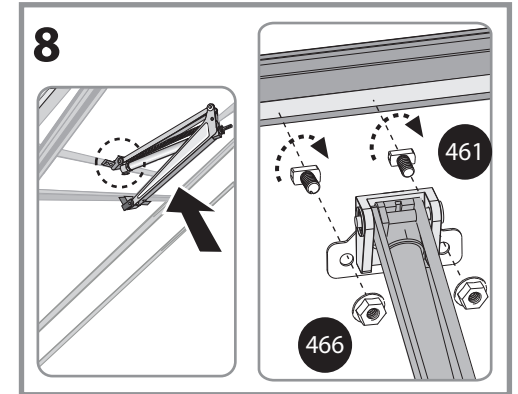
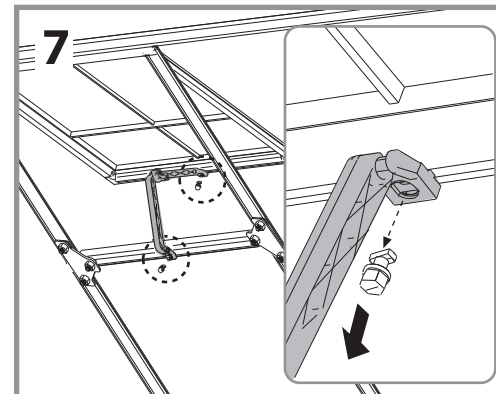
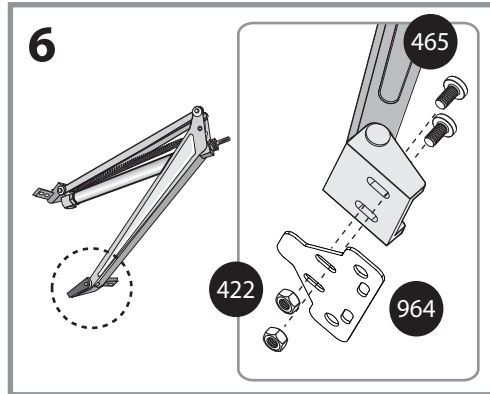
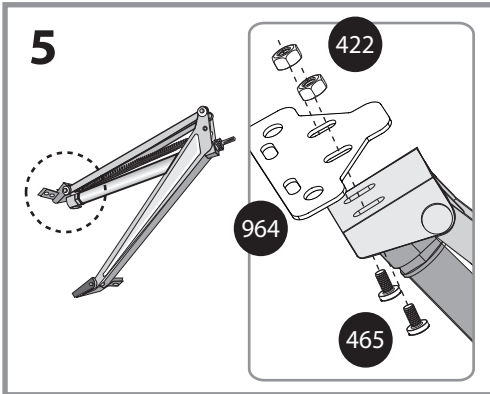
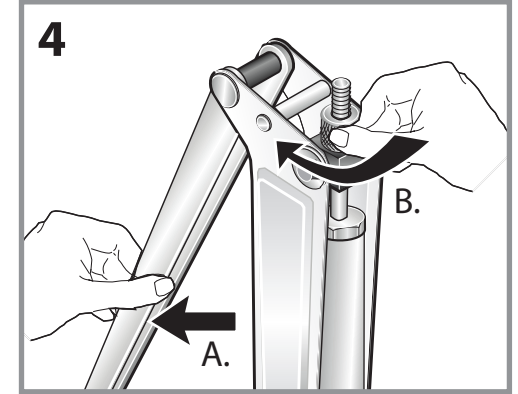
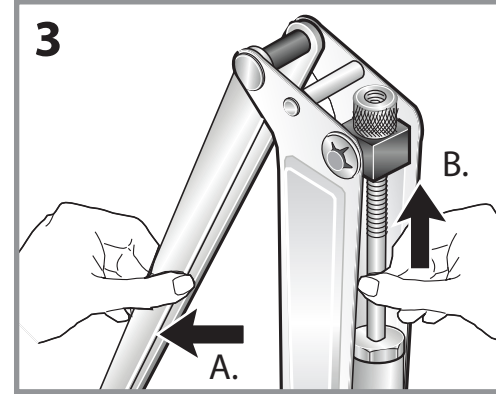
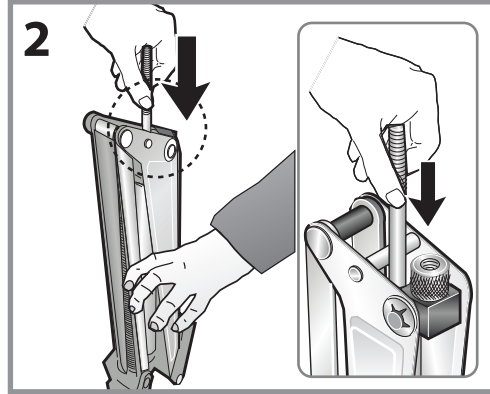
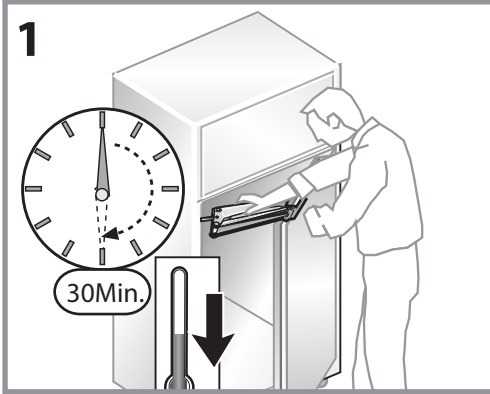

# HOW TO ASSEMBLE

## PLANT HANGERS

Suitable for Palram - Canopia Greenhouses

### IMPORTANT!

Please read these instructions carefully before starting assembly.  
Keep these instructions in a safe place for future reference.

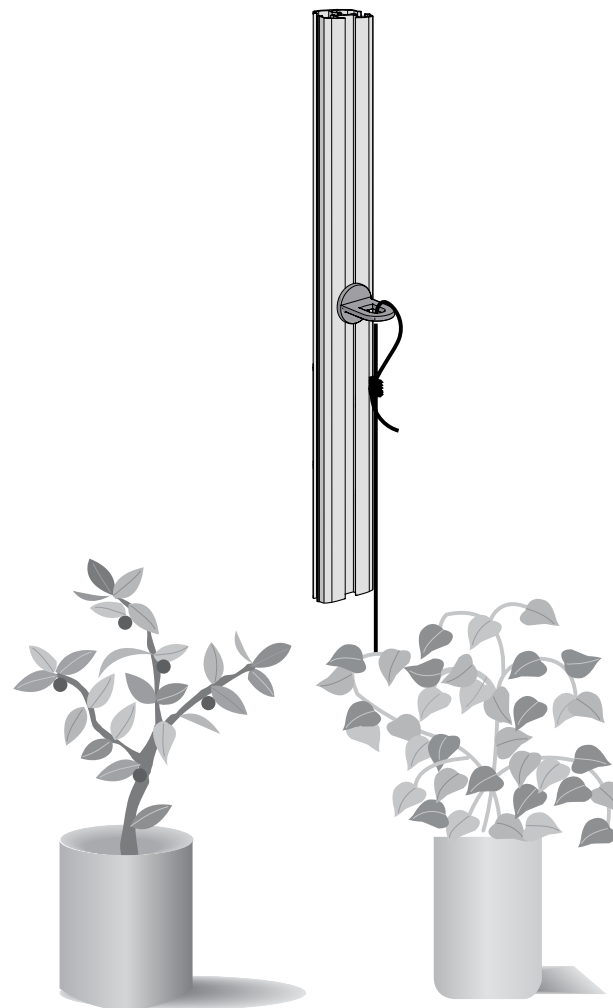

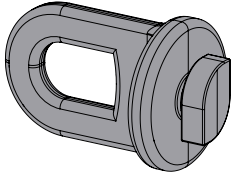
Item		Qty.
70		10

