

Shark

Performance Lift-Away[®] Upright Vacuum

UV700 Series

OWNER'S GUIDE

duo clean

**Self-Cleaning Brushroll
Technology**



IMPORTANT SAFETY INSTRUCTIONS

FOR HOUSEHOLD USE ONLY • PLEASE READ CAREFULLY BEFORE USE

If the plug does not fit fully into the outlet, reverse the plug. If it still does not fit, contact a qualified electrician. **DO NOT force into outlet or try to modify to fit.**

WARNING

To reduce the risk of fire, electric shock, injury, or property damage:

GENERAL WARNINGS

When using an electrical appliance, basic precautions should always be followed, including the following:

1. Your vacuum cleaner may consist of a motorized nozzle, wand, hose, and/or vacuum pod. This device contains electrical connections, electrical wiring, and moving parts that potentially present risk to the user.
2. Use only identical replacement parts.
3. Carefully observe and follow the instructions provided below to avoid improper use of the appliance. **DO NOT** use the vacuum for any purpose other than those described in this manual.
4. Before use, carefully inspect all parts for any damage. **DO NOT** use if any parts are damaged.
5. The use of an extension cord is **NOT** recommended.
6. This vacuum cleaner contains no serviceable parts.

USE WARNINGS

7. This appliance can be used by persons with reduced physical, sensory or mental capabilities or lack of experience and knowledge if they have been given supervision or instruction concerning use of the appliance in a safe way and understand the hazards involved. Cleaning and user maintenance shall not be made by children. Keep the appliance and its cord out of reach of children. **DO NOT** allow the appliance to be used by children. **DO NOT** allow to be used as a toy. Close supervision is necessary when used near children.

15. Keep nozzle and all vacuum openings away from hair, face, fingers, uncovered feet, or loose clothing.

16. DO NOT use if vacuum cleaner is not working as it should, or has been dropped, damaged, left outdoors, or dropped into water.

17. Use extra care when cleaning on stairs.

18. DO NOT leave the vacuum cleaner unattended while plugged in.

19. When powered on, keep the vacuum cleaner moving over the carpet surface at all times to avoid damaging the carpet fibers.

20. DO NOT place vacuum cleaner on unstable surfaces such as chairs or tables.

21. Your Shark® vacuum may not be designed to stand up on its own. When taking a break from cleaning, you may need to lean it against furniture or a wall, or lay it flat on the floor. Using the vacuum for an application where the unit lacks stability may result in personal injury.

22. DO NOT use to pick up:

- a) Liquids
- b) Large objects
- c) Hard or sharp objects (glass, nails, screws, or coins)
- d) Large quantities of dust (drywall dust, fireplace ash, or embers). **DO NOT** use as an attachment to power tools for dust collection.
- e) Smoking or burning objects (hot coals, cigarette butts, or matches)
- f) Flammable or combustible materials (lighter fluid, gasoline, or kerosene)
- g) Toxic materials (chlorine bleach, ammonia, or drain cleaner)

23. DO NOT use in the following areas:

- a) Poorly lit areas
- b) Wet or damp surfaces
- c) Outdoor areas
- d) Spaces that are enclosed and may contain explosive or toxic fumes or vapors (lighter fluid, gasoline, kerosene, paint, paint thinners, mothproofing substances, or flammable dust)

24. Turn off all controls before plugging in or unplugging the vacuum.

25. Unplug from electrical outlet when not in use and before any maintenance or cleaning.

26. Hand wash with water only. Washing with cleaning chemicals could damage the unit.

27. During cleaning or routine maintenance, **DO NOT** cut anything other than hair, fibers, or string wrapped around the brushroll.

28. Allow all filters to air-dry completely before replacing in the vacuum to prevent liquid from being drawn into electric parts.

29. Make sure the dust cup and all filters are in place after routine maintenance.

30. If provided, secure the power cord around the two cord hooks during storage.

To reduce the risk of electric shock, this appliance has a polarized plug (one blade is wider than the other). This plug will fit in a polarized outlet only one way. If the plug does not fit fully in the outlet, reverse the plug. If it still does not fit, contact a qualified electrician to install the proper outlet. Do not change the plug in any way.

SAVE THESE INSTRUCTIONS

WHAT'S INSIDE

- A Wand
- B Motorized Floor Nozzle
- C Handle & Hose
- D Vacuum Pod
- E Pet Hair Tool
- F Crevice Tool
- G Dusting Brush

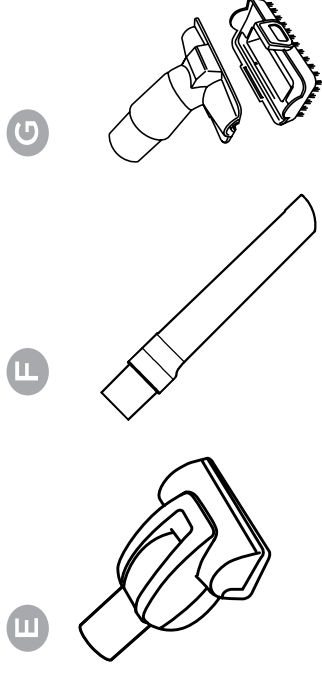

For additional parts and accessories, visit sharkaccessories.com

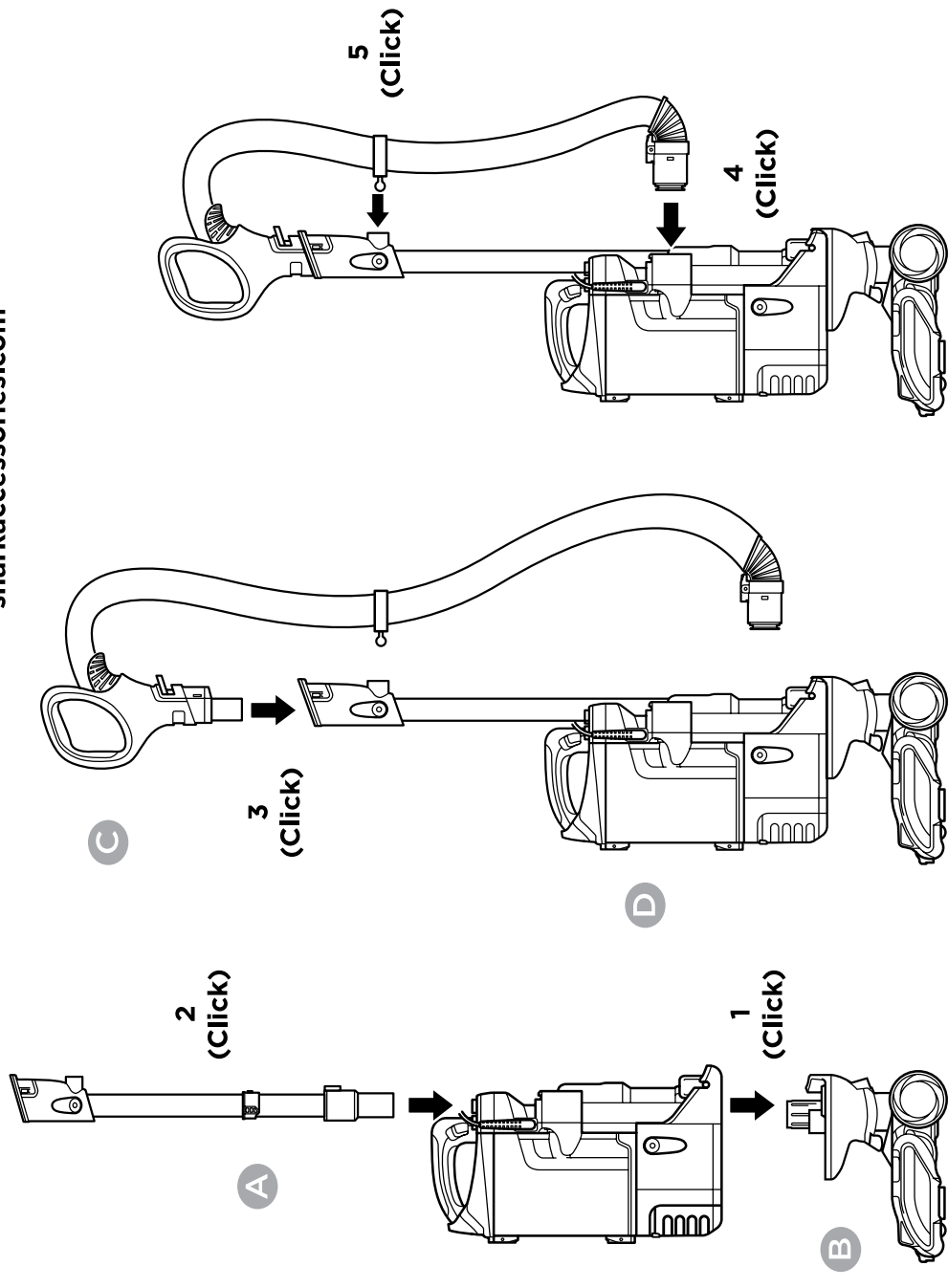

ASSEMBLY

1. Place **Motorized Floor Nozzle** on floor and attach **Pod**, pressing it in until it clicks securely into place.
2. Insert **Wand** into pod, pressing it in until it clicks securely into place.
3. Insert **Handle** into wand, pressing it in until it clicks securely into place.
4. Connect **Hose** into back of pod, pressing it in until it clicks securely into place.
5. Insert **Hose Clip** into back of handle until it clicks into place.

IMPORTANT: For proper operation, ensure all connections are securely clicked into place.

1. UPRIGHT

Power

Press the Power/Surface Selector button to turn the vacuum on or off.

Floor Setting

Slide the Power/Surface Selector button up or down to choose floor type.

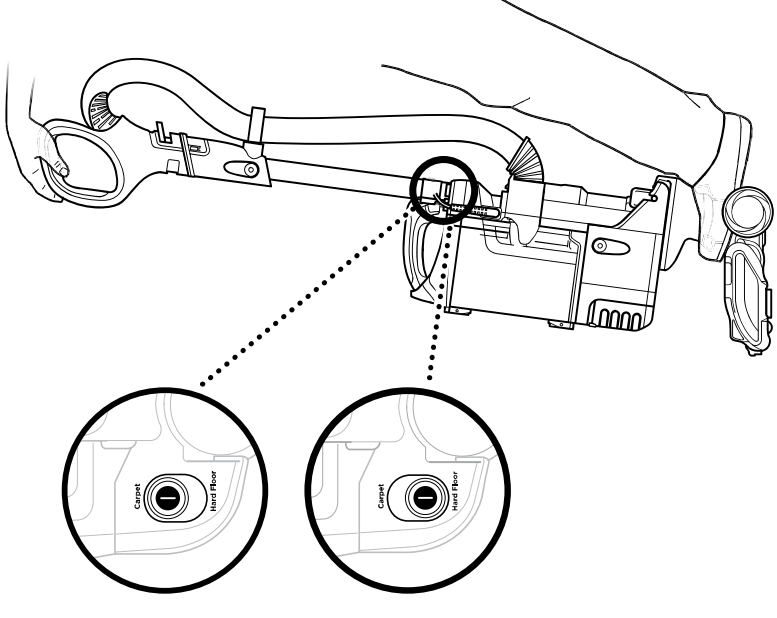

2. LIFT-AWAY® OPERATION

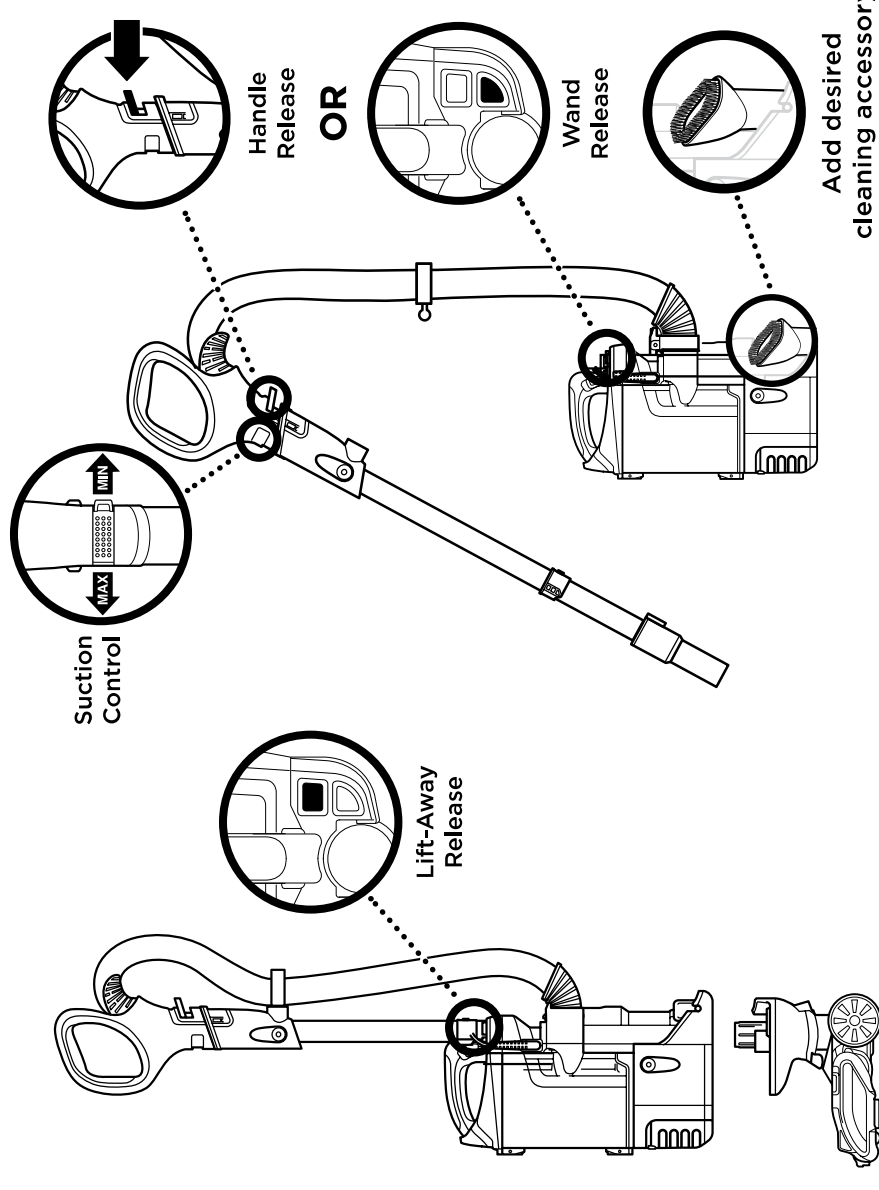

WHOLE-HOME CLEANING

SETTINGS

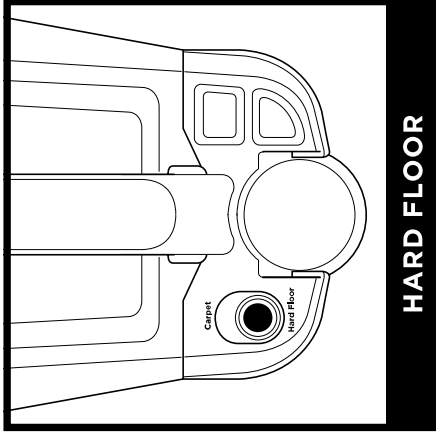

HARD FLOOR

Slide selector to Hard Floor, then press selector button to turn on power.

NOTE: The brushrolls will not spin unless the wand is reclined.

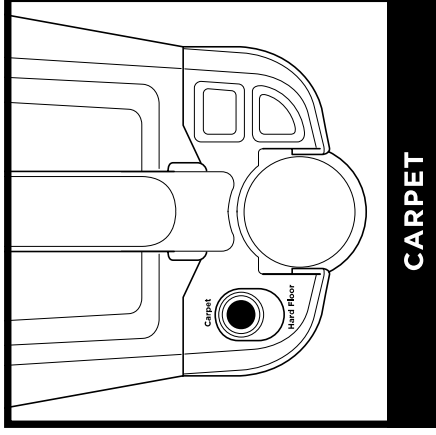

CARPET

Slide selector to Carpet, then press selector button to turn on power. Brushrolls will spin faster.

NOTE: The brushrolls will not spin unless the wand is reclined.

SUCTION CONTROL

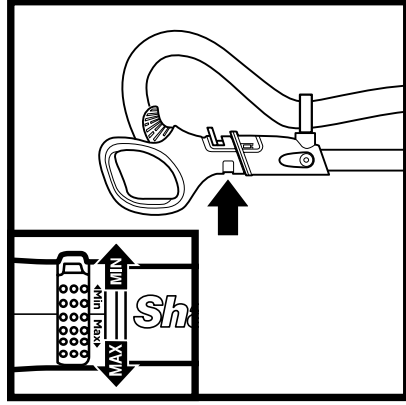

Suction Control Collar offers variable suction based on your needs. Slide to **MIN** to reduce suction and increase maneuverability on carpets. Slide to **MAX** to increase suction on bare floors.

BRUSHROLL INDICATOR LIGHT

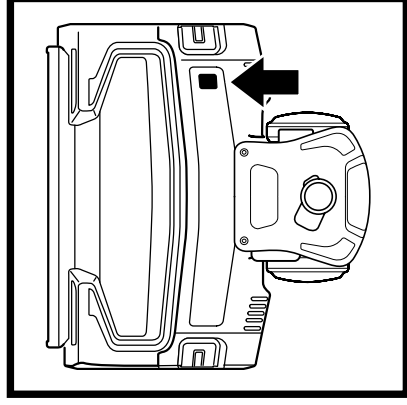

WHAT DOES THE BRUSHROLL INDICATOR LIGHT MEAN?

Solid Green: The brushroll and Soft Roller are spinning and working properly.

Solid Red: There is a jam in the brushroll area. Turn off the vacuum and unplug it, then remove any blockages in the nozzle.

Flashing Red: Turn off the vacuum, unplug it, and remove any blockages. Let the vacuum cool down for at least 60 minutes before restarting. See Troubleshooting section for more information.

Solid Green with Headlights Flashing: The brushroll garage lid is not properly closed. Press down firmly on both sides of the lid until it clicks into place.

WHOLE-HOME CLEANING

CLEANING MODES

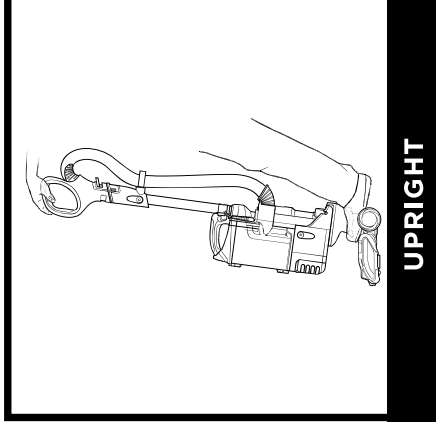

UPRIGHT

To engage brushrolls, turn power on, then step on floor nozzle and tilt handle back.

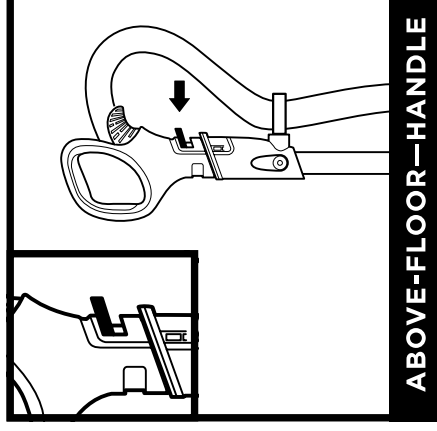

ABOVE-FLOOR—HANDLE

Press the **Handle Release Latch** to detach the handle from the wand.

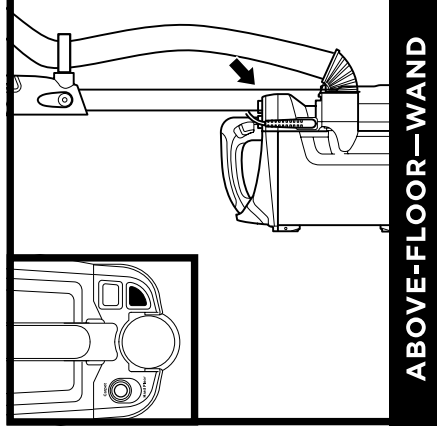

ABOVE-FLOOR—WAND

Press the **Wand Release** button to detach the wand from the pod.

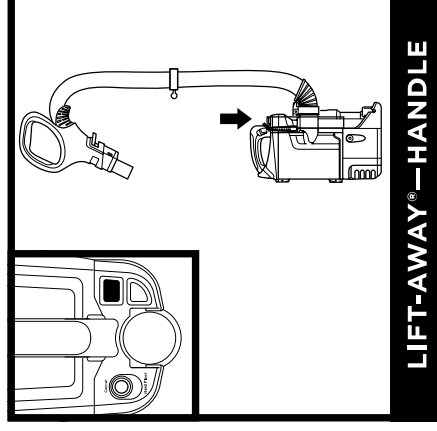

LIFT-AWAY®—HANDLE

Detach wand from pod, then detach the handle from the wand (see above). Press the **Lift-Away** button to detach the pod from the floor nozzle.

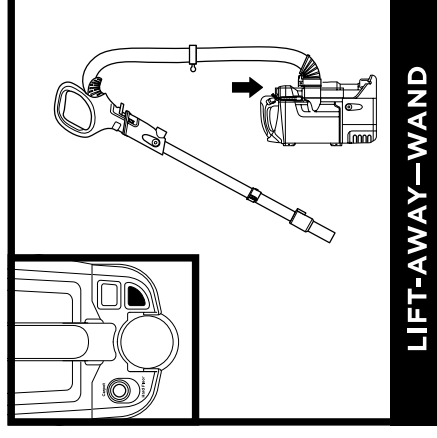

LIFT-AWAY®—WAND

Detach wand from pod (see above). Press the **Lift-Away** button to detach the pod from the floor nozzle.

NOTE: For deep cleaning per ASTM F 608 (embedded dirt in carpets) please set to **Carpet**. **NOTE:** For particularly stubborn stuck-on dust messes on hard floors, set to **Carpet**.

NOTE: All accessories are compatible with both the wand and the handle.

EMPTYING THE DUST CUP

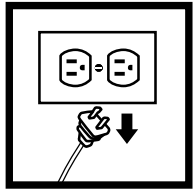

IMPORTANT: Unplug the power cord before performing any maintenance.

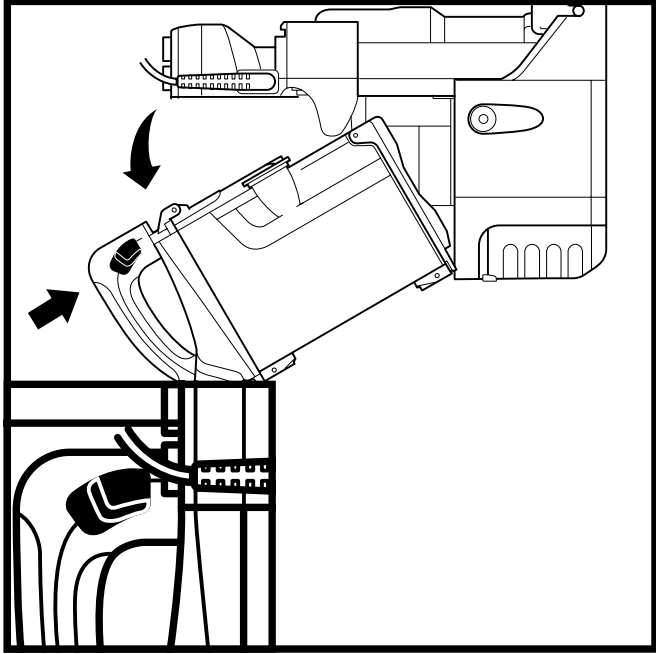

To remove **Dust Cup**, slide up the buttons on both sides of the handle. Tilt dust cup, then lift to remove.

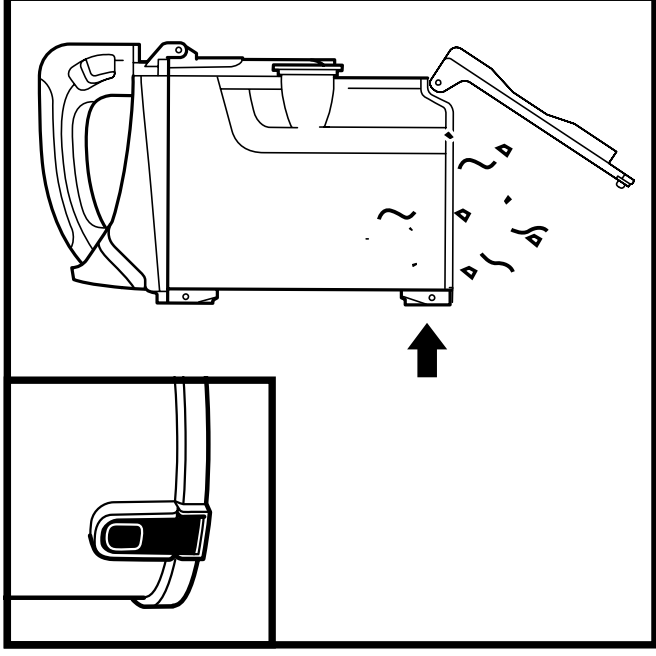

To empty debris, press lower release button and bottom of dust cup will drop open.

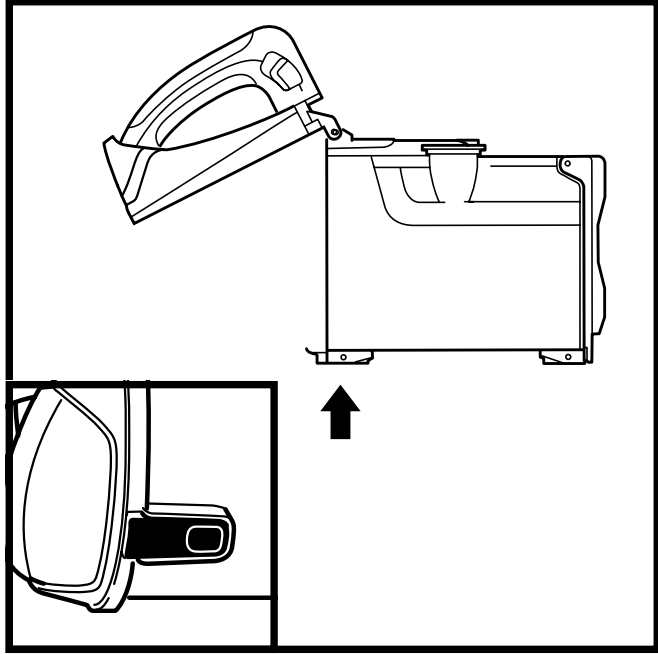

To remove collected debris from **Lint Screen**, press top release button and lift handle to open. Gently brush lint screen to clean.

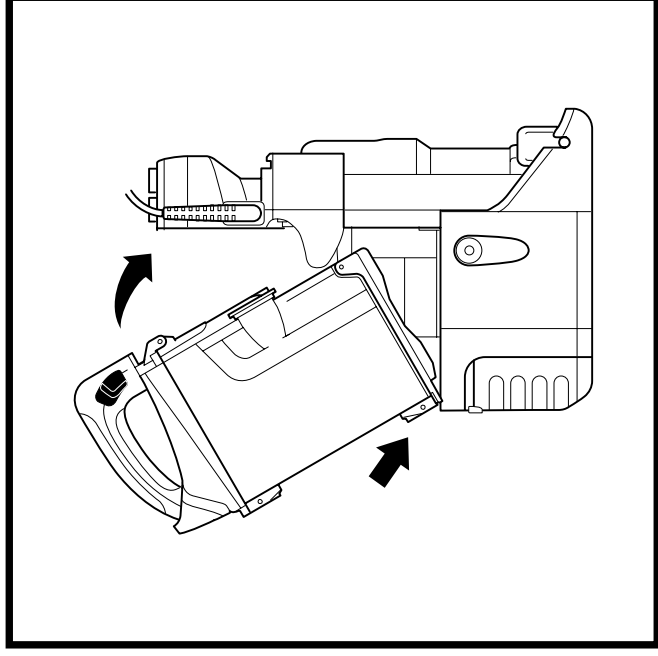

To reinstall, place bottom of dust cup into pod and then tilt until it clicks into place.

CLEANING AND REPLACING THE FILTERS

CLEANING FILTERS

Regularly rinse and replace the filters to maintain your vacuum's suction power.

To prevent damage from cleaning chemicals, rinse filters with cold water only. Allow all filters to air-dry for at least 24 hours before reinstalling them to prevent liquid from being drawn into electric parts.

IMPORTANT: DO NOT use soap when cleaning the filters.

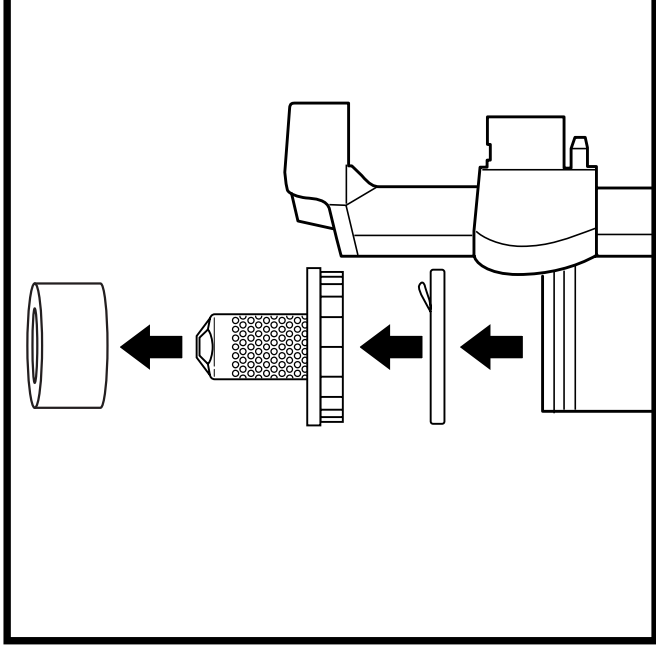

CLEAN PRE-MOTOR FILTERS EVERY 3 MONTHS

Remove **Dust Cup**, then lift out **Filters**.

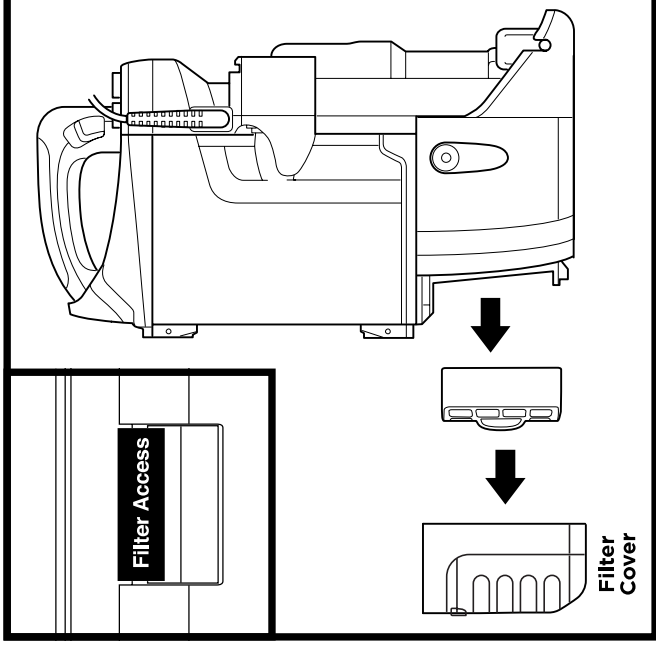

CLEAN HEPA FILTER EVERY YEAR

Press **Filter Access** button at bottom of **Filter Cover**. Tilt cover and lift out. Remove **HEPA Filter**.

To reinstall, insert HEPA filter into unit and replace the cover.

Self-Cleaning Brushroll Technology

The self-cleaning brushroll actively removes hair wrap as you vacuum. If you run over a hard or sharp object or notice a noise change while vacuuming, check for blockages or objects caught in the brushroll.

CLEANING THE BRUSHROLL

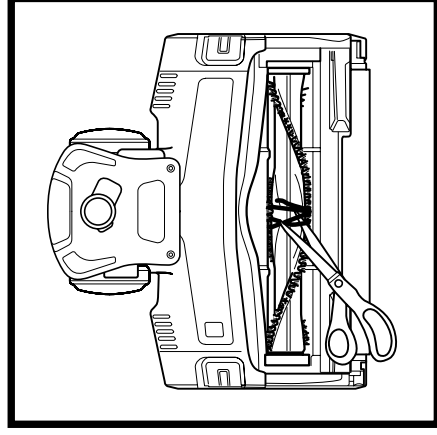
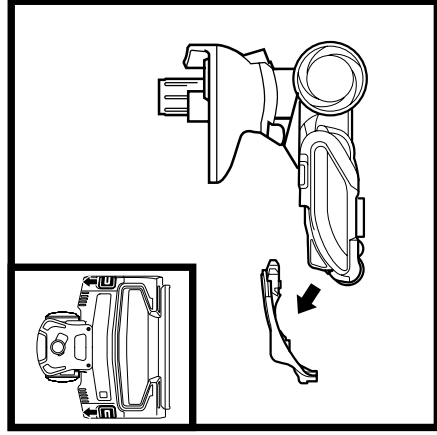

To open the brushroll garage, slide both release buttons on the floor nozzle away from you, toward the back of the nozzle, then lift off the lid. Clear away any objects or debris. To close the brushroll garage, insert the 3 tabs on top of lid into the 3 slots in the nozzle, then push down on both sides of the lid until it clicks securely into place.

NOTE: If any hair is wrapped around the brushroll, extending cleaning time will allow the self-cleaning brushroll to remove it for you. If some fibers remain wrapped around brushroll after continued use, open the brushroll garage lid and carefully remove them.

CLEANING THE SOFT ROLLER

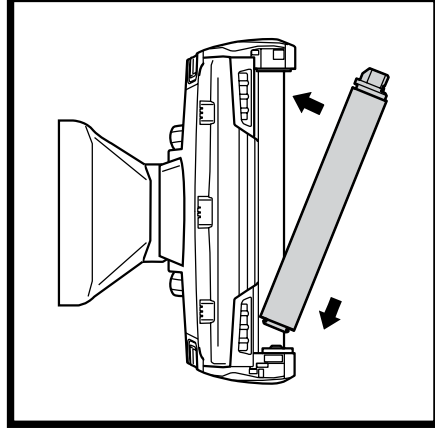
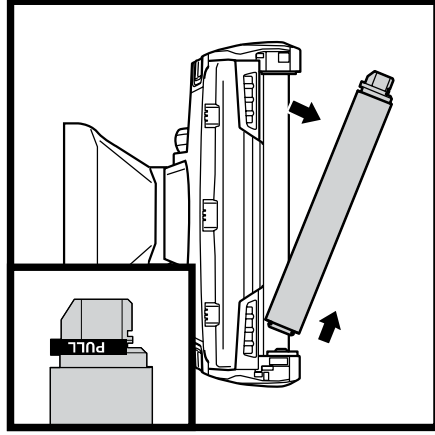

To remove the **Soft Roller** from the nozzle, lift it out by the pull tab off any loose debris. Use a dry towel to wipe the Soft Roller clean, or to remove any debris caught in the teeth behind it.

Hand wash the Soft Roller as needed. Use only water, and let air-dry completely for at least 24 hours. Reinsert the Soft Roller under the rubber bumper in the front of the nozzle until it clicks into place.

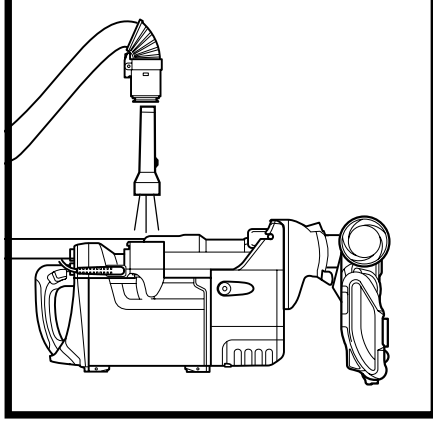

Detach hose from vacuum pod, and check hose and opening on back of pod for blockages.

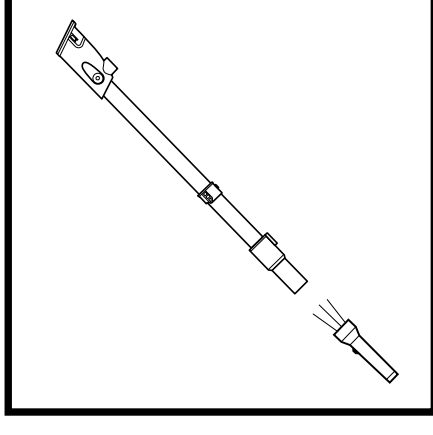

Detach wand from floor nozzle and handle, and check both ends for blockages.

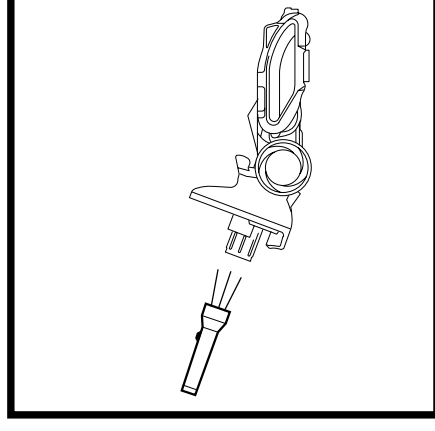

Detach wand from floor nozzle, tilt nozzle neck back, and check opening for blockages.

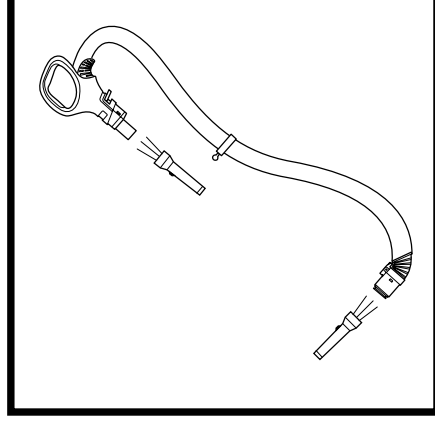

Detach handle from wand and hose from the vacuum pod, and check openings for blockages.

AVAILABLE ACCESSORIES

- A Crevice Tool**
This slender tool offers extended reach to access corners, baseboards, tight spaces, and ceilings.
- B Dusting Brush**
This brush dusts and cleans delicate surfaces. Great for use on fans, blinds, lampshades, and keyboards.
- C Pet Power Brush**
The turbine brush loosens and removes pet hair and debris from carpets, and powerfully deep-cleans dander out of upholstery and other surfaces.
- D Duster Crevice Tool**
Two cleaning tools in one. The crevice tool gives you extended reach to clean in tight spaces, while the soft brush is ideal for dusting delicate surfaces.
- E Multi-Angle Dusting Brush**
This brush dusts and cleans delicate surfaces. Great for use on fans, blinds, lampshades, and keyboards.
- F Anti-Allergen Dust Brush**
This brush features nylon fiber bristles specifically designed for removing fine dust and allergen particles from the most delicate surfaces.
- G Upholstery Tool**
Picks up pet hair, dust and large debris from mattresses, couches, curtains, and other delicate upholstered surfaces.
- H Wide Upholstery Tool**
The wide cleaning path helps remove pet hair, dust, and large debris from mattresses, couches, curtains, lampshades, and other delicate upholstered surfaces.
- I Pet Multi-Tool**
A single convertible tool for cleaning tough pet messes two ways: use the stiff bristle brush to clean stuck-on debris, or take off the bristles to reveal an upholstery tool perfect for removing stubborn pet hair and large piles of debris.
- J Under-Appliance Wand**
Clean under and behind hard-to-move appliances and furniture with this adjustable 36" tool. Flip the extension piece over to clean the underside of appliances.
- K Home & Car Detail Kit**
Deep-clean your car like a professional detailer, or clean hard-to-reach areas in your home. Micro-sized tools let you clean around delicate objects and access the tightest spaces like car vents and computer keyboards.
- L Accessory Bag**
This convenient accessory storage bag measures 32 cm x 70 cm and fits the Under-Appliance Wand. Smaller size available at sharkaccessories.com.

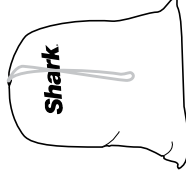
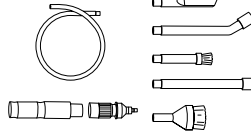
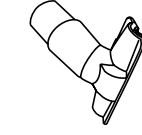
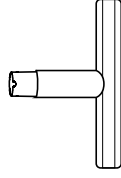
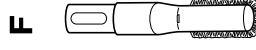
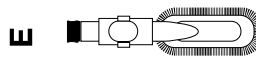
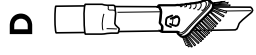
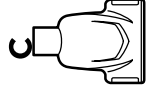
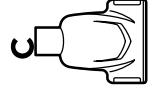

TROUBLESHOOTING

Vacuum is not picking up debris. No suction or light suction.

- Check filters to see if they need cleaning. Follow instructions for rinsing and air-drying the filters before reinserting in the vacuum.
- Dust cup may be full; empty dust cup.
- Check hose, hose connections, nozzle, wand, pod, and accessories for blockages. Clear any blockages found. See the Checking for Blockages section for more information.
- If any hair, string, or carpet fibers are wrapped around the brushroll, extend cleaning time to allow the self-cleaning brushroll to remove them. If some hair or fibers remain wrapped around brushroll after continued use, garage lid. Carefully clear away any debris or fibers. See Cleaning the Brushroll section for more information.

Vacuum is hard to maneuver on high pile/plush carpets or lifts area rugs.

- Make sure selector switch is set to Hard Floor.
- Suction is powerful. Take care when vacuuming area rugs or rugs with delicately sewn edges.
- To minimize suction, slide the Suction Control collar to MIN.

Brushrolls do not spin.

- If the brushroll indicator light turns red, turn off the power. Slide the Suction Control collar to MIN, then turn the vacuum back on.
- If the brushroll indicator light is still red, there might be a clog. Immediately turn off and unplug the vacuum. Remove pod from floor nozzle and clear any blockages. Reconnect nozzle, plug in vacuum, and turn on power.
- With the power on, recline the handle, which will automatically activate the brushrolls.
- Ensure that the selector switch is set to Carpet for brushroll to spin.
- If the brushroll indicator light is green and the headlights are flashing, this means that the brushroll garage lid is not properly closed. Press down firmly on both sides of the lid until it clicks into place.

Vacuum turns off on its own or indicator light flashes red.

If your vacuum overheats, the thermostat will automatically turn off the motor. Follow these steps to restart:

1. Turn vacuum off and unplug it.
2. Empty the dust cup and clean the filters. See Emptying the Dust Cup and Cleaning and Replacing the Filters sections.
3. Check for blockages in hose, wand, nozzle, accessories, and inlet openings.
4. Allow unit to cool for a minimum of 60 minutes.
5. Plug in the vacuum and press the selector button to turn it on.

NOTE: Not all accessories come with all units. For a list of the accessories included with this model, see the top inside flap of the box. To order additional accessories, visit sharkaccessories.com.

FIVE (5) YEAR LIMITED WARRANTY

The Five (5) Year Limited Warranty applies to purchases made from authorized retailers of **SharkNinja Operating LLC**. Warranty coverage applies to the original owner and to the original product only and is not transferable.

SharkNinja warrants that the unit shall be free from defects in material and workmanship for a period of five (5) years from the date of purchase when it is used under normal household conditions and maintained according to the requirements outlined in the Owner's Guide, subject to the following conditions and exclusions:

What is covered by this warranty?

1. The original unit and/or non-wearable components deemed defective, in SharkNinja's sole discretion, will be repaired or replaced up to five (5) years from the original purchase date.
2. In the event a replacement unit is issued, the warranty coverage ends six (6) months following the receipt date of the replacement unit or the remainder of the existing warranty, whichever is later. SharkNinja reserves the right to replace the unit with one of equal or greater value.

What is not covered by this warranty?

1. Normal wear and tear of wearable parts (such as foam filters, HEPA filters, pads, etc.), which require regular maintenance and/or replacement to ensure the proper functioning of your unit, are not covered by this warranty. Replacement parts are available for purchase at sharkaccessories.com.
2. Any unit that has been tampered with or used for commercial purposes.
3. Damage caused by misuse (e.g., vacuuming up water or other liquids), abuse, negligent handling, failure to perform required maintenance (e.g., not cleaning the filters), or damage due to mishandling in transit.
4. Consequential and incidental damages.
5. Defects caused by repair persons not authorized by SharkNinja. These defects include damages caused in the process of shipping, altering, or repairing the SharkNinja product (or any of its parts) when the repair is performed by a repair person not authorized by SharkNinja.
6. Products purchased, used, or operated outside North America.

How to get service

If your appliance fails to operate properly while in use under normal household conditions within the warranty period, visit sharkclean.com/support for product care and maintenance self-help. Our Customer Service Specialists are also available at **1-800-798-7398** to assist with product support and warranty service options, including the possibility of upgrading to our VIP warranty service options for select product categories.

SharkNinja will cover the cost for the customer to send in the unit to us for repair or replacement. A fee of \$24.95 (subject to change) will be charged when SharkNinja ships the repaired or replacement unit.

How to initiate a warranty claim

You must call **1-800-798-7398** to initiate a warranty claim. You will need the receipt as proof of purchase. A Customer Service Specialist will provide you with return and packing instruction information.

How state law applies

This warranty gives you specific legal rights, and you also may have other rights that vary from state to state. Some states do not permit the exclusion or limitation of incidental or consequential damages, so the above may not apply to you.

Benefits of registering your product and creating an account:

- Get easier, faster product support and access to warranty information
- Access troubleshooting and product care instructions
- Be among the first to know about exclusive product promotions



REGISTER YOUR PURCHASE

 registry.yourshark.com

 Scan QR code using mobile device

RECORD THIS INFORMATION

Model Number: _____

Serial Number: _____

Date of Purchase: _____
(Keep receipt)

Store of Purchase: _____

TECHNICAL SPECIFICATIONS

Voltage: 120V~ 60Hz

Watts: 900W

TIP: You can find the model and serial numbers on the QR code label on the bottom of the back of the vacuum pod.

PLEASE READ CAREFULLY AND KEEP FOR FUTURE REFERENCE.

This Owner's Guide is designed to help you get a complete understanding of your new Shark® vacuum.

SharkNinja Operating LLC
US: Needham, MA 02494
CAN: Ville St-Laurent, QC H4S 1A7
1-800-798-7398
sharkclean.com

Illustrations may differ from actual product. We are constantly striving to improve our products; therefore the specifications contained herein are subject to change without notice.

For SharkNinja U.S. Patent information, visit sharkninja.com/uspatents

© 2020 SharkNinja Operating LLC. DUOCLEAN, LIFT-AWAY, and SHARK are registered trademarks of SharkNinja Operating LLC.

UV700_IB_E_REV_Mv10
PRINTED IN CHINA



@sharkcleaning