



CHEFMAN.

**Family-Sized
Glass Top
Warming Tray**



RJ22-TC-V3-BLK



Get to Know Your Warming Tray

1. Stainless steel frame
2. Tempered glass heating surface
3. Cool-touch handles
4. Temperature control knob
5. HOT indicator light



READ ALL INSTRUCTIONS BEFORE USE

For your safety and continued enjoyment of this product, always read the instruction manual before using.



Get to Know Your Warming Tray

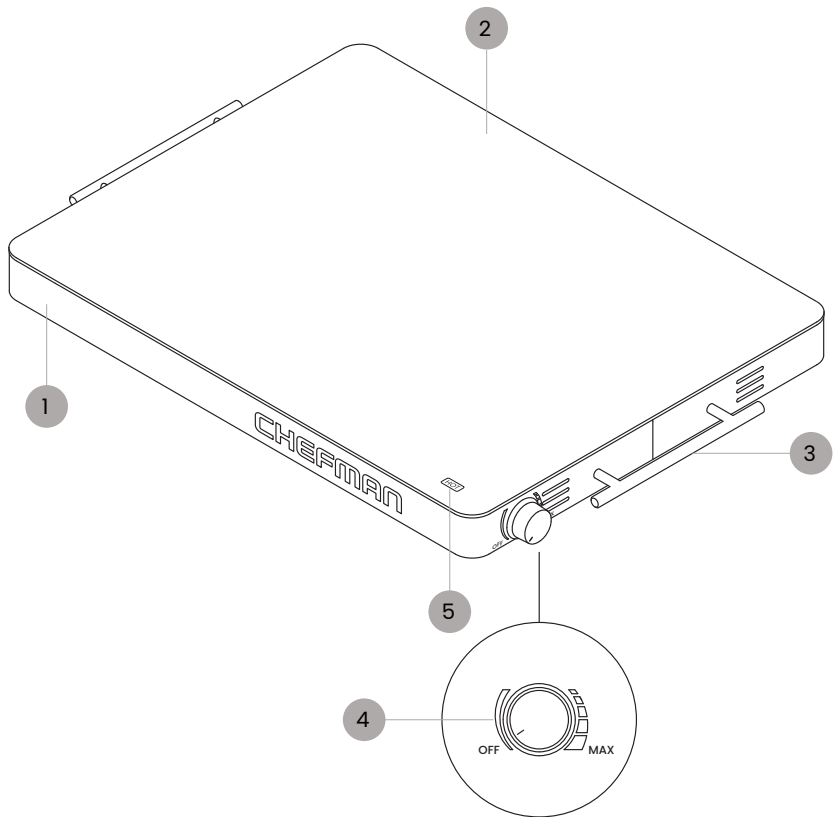



SAFETY INSTRUCTIONS & IMPORTANT SAFEGUARDS

WARNING: When using electrical appliances, basic safety precautions should always be followed

1. Read all instructions.
2. **Do NOT** touch hot surfaces. Use handles or knobs.
3. To protect against electric shock do not immerse cord, plugs, or unit body in water or other liquid.
4. Close supervision is necessary when any appliance is used by or near children.
5. Unplug from outlet when not in use and before cleaning. Allow to cool before putting on or taking off parts, and before cleaning the appliance.
6. **Do NOT** operate any appliance with a damaged cord or plug, or after the appliance malfunctions or has been damaged in any manner. Contact Chefman® Customer Support for examination, repair, or adjustment.
7. The use of accessory attachments not recommended by Chefman® may cause injuries.
8. **Do NOT** use outdoors
9. **Do NOT** let cord hang over edge of table or counter, or touch hot surfaces.
10. **Do NOT** place on or near a hot gas or electric burner, or in a heated oven.
11. Extreme caution must be used when moving an appliance containing hot oil or other hot liquids.
12. To disconnect, turn any control to off, then remove plug from wall outlet.
13. **Do NOT** use appliance for other than intended use.
14. **Do NOT** cook on a broken cooktop. If the cooktop should break, cleaning solutions and spills may penetrate the broken cooktop and create a risk of electric shock.
15. Clean cooktop with caution. If a wet sponge is used to wipe spills on a hot cooking area, be careful to avoid steam burns. Some cleaners can produce noxious fumes if applied to a hot surface.





SAFETY INSTRUCTIONS & IMPORTANT SAFEGUARDS

16. Always place the warming tray on a flat, steady surface. Keep at least 8 inches of space between the warming tray and other objects to avoid interruption of airflow around the unit.
17. Only place the unit on heat-resistant surfaces.
18. **Do NOT** place non-heat-resistant objects or containers on the warming tray. This includes plastic containers.
19. This warming tray can be kept on for up to 72 hours. Do not use for prolonged periods of time.
20. **Do NOT** leave the warming tray unattended while in use.
21. **Do NOT** place the warming tray in a dishwasher.
22. **Do NOT** cover the surface or side vents of the warming tray. Covering this unit can cause a fire hazard. Covering the unit with aluminum foil can cause the glass surface to shatter.



SAVE THESE INSTRUCTIONS FOR HOUSEHOLD USE ONLY





SAFETY INSTRUCTIONS & IMPORTANT SAFEGUARDS

WARNING: This appliance has a polarized plug (one blade is wider than the other). This plug is intended to fit into a polarized outlet only one way. If the plug does not fit fully into the outlet, reverse the plug. If it still does not fit, contact a qualified electrician. Do not attempt to modify the plug in any way or force it into the outlet. This could result in injury or electrical shock.

Short Cord Instructions

A short power-supply cord is provided to reduce the hazards of entanglement or tripping over a longer cord. Longer detachable power-supply cords or extension cords are available and may be used if care is exercised in their use. If a longer detachable power-supply extension cord is used:

1. The marked electrical rating of the extension cord should be at least as great as the electrical rating of the appliance.
2. The longer cord should be arranged so that it will not drape over the countertop or tabletop where it can be pulled on by children or tripped over.





SAFETY INSTRUCTIONS & IMPORTANT SAFEGUARDS

Power Cord Safety Tips

1. Never pull or yank on the cord or the appliance.
2. To insert the plug, grasp it firmly and guide it into the outlet.
3. To disconnect appliance, grasp the plug and remove it from the outlet.
4. Never use the product if the power cord shows signs of excessive wear. Contact Chefman® Customer Support for additional guidance and support.
5. Never wrap the cord tightly around the appliance, as this could place undue stress on the cord where it enters the appliance and cause it to fray and break.

DO NOT OPERATE APPLIANCE IF THE POWER CORD SHOWS ANY DAMAGE OR IF THE APPLIANCE WORKS INTERMITTENTLY OR STOPS WORKING ENTIRELY.



California Proposition 65:

(Applicable for California Residents only)

WARNING: Cancer and Reproductive Harm
www.P65Warnings.ca.gov

Do not place the appliance on a stovetop or any other heatable surface, even if stovetop is not on. Doing so is a fire hazard.





How to Use the Warming Tray



Before First Use

1. Remove all packaging materials, such as plastic bags and foam inserts.
2. Read and remove all stickers on the unit except for the rating label.
3. Wipe the surface with a damp towel to remove any packaging dust. (Never immerse the warming tray, its cord, or plug in water or any other liquid.)

Warming Instructions

1. Place the tray on a hard, flat, heat-resistant surface near an outlet. Ensure it is at least 8 inches away from all objects and sources of liquid.
WARNING: Do not place the warming tray on butcher block, wood, recycled material, bamboo, or plastic, as they are not heat resistant. Heat-resistant surfaces include granite, stainless steel, quartz, marble, glass, soapstone, travertine, and limestone.
2. Plug in the tray. Use the temperature control knob to select a heat level, up to the MAX marking. Once a temperature is selected, the HOT indicator light will illuminate. (**NOTE:** The HOT light does not indicate that the surface has fully come to temperature, only that the unit is heating.) **WARNING:** Never cover or wrap the tray in foil, plastic, cloth, or any other material. Doing so blocks airflow, which can cause a fire and can cause the glass top to shatter.
3. Once the tray is warm, place hot or warm food in heat-resistant containers (such as a pot, pan, or tempered glass dish) on the top. Do not place plastic containers on the surface. **CAUTION:** The surface of the tray is HOT. Do not touch the surface with bare hands. Use potholders to handle hot dishes and pans.
4. Never move the tray when it is in use or items are on top of it.
5. When finished using the tray, turn the temperature control knob to OFF, then unplug the tray from the power outlet. Let cool completely before cleaning.



Tips & Troubleshooting

- The warming tray is not a cooking appliance. It is designed to keep already-cooked food warm. It is NOT designed to cook or defrost food.
- Only use containers that are heat resistant on the warming tray. Plastic containers or other materials that are not heat resistant may melt and cause damage to the tray and run a risk of burning or fire.
- Never place any non-heat-resistant items, such as plastic utensils, on or near the tray.
- To retain both heat and moisture, consider covering any foods kept on the tray.
- Use the tray for keeping hot drinks like mulled wine warm during serving.
- Be sure to follow proper food-safety guidelines for keeping and serving warm foods.
- Ceramic, stoneware, and cast-iron cookware may have unfinished, rough bases that can scratch the surface. Avoid using these on the tray, or use with care.
- Check that the bottoms of dishes and pans are clean before placing on the tray; if dirty, they can leave marks on the glass.





Keep It Clean

The glass surface of the warming tray is easy to keep clean.

1. Before cleaning, turn off the unit, unplug it from the power outlet, and let it cool completely.
2. When it is completely cool, clean the warming tray with a mild detergent and a soft, damp cloth. Do not use abrasive cleansers or scouring pads, which can scratch.
3. Never immerse the tray, its cord, or its plug in water or any other liquids. Do not allow water to spill or seep into the tray's frame, or allow the heating elements to come into contact with water.
4. Dry completely with a soft cloth. Store in a cool, dry place.





Terms & Conditions

Limited Warranty

RJ Brands, LLC d/b/a Chefman® offers a limited 1-year Warranty (the “Warranty”) available on sales through authorized distributors and retailers only. Please note that this Warranty becomes valid from the date of initial retail purchase and that the Warranty is non-transferable and applies only to the original purchaser.

This Warranty is void without proof of purchase within the United States and Canada. Please be aware that this Warranty supersedes all other warranties and constitutes the entire agreement between the consumer and Chefman®. Any changes to the Terms and Conditions of this Warranty must be in writing, signed by a representative of Chefman®. No other party has the right or ability to alter or change the Terms and Conditions of this Warranty.

We may ask you to please submit, via email, photos and/or video of the issue you are experiencing. This is to help us better assess the matter and possibly offer a quick fix. Photos and/or video may also be required to determine Warranty eligibility.

We encourage you to register your product. Registering can make the Warranty process easier and can keep you informed of any updates or recalls on your product. To register, follow the directions on the Chefman® Warranty Registration page in the Chefman® User Guide. Please retain your proof of purchase even after registering. In the event that you do not have proof of your purchase date, we may declare your Warranty void or we may, at our sole discretion, apply the date of manufacture as the purchase date for purposes of this Warranty.





Terms & Conditions

What the Warranty Covers

- **Manufacturer Defects** – Chefman® products are warranted against defects in material and workmanship, under normal household use, for a period of 1 year from the date of purchase when used in accordance with the directions listed in the Chefman® User Guide. If your product does not work as it should, please contact Customer Support at support@chefman.com so that we may assist you.

This Warranty Does Not Cover

- **Misuse**

Damage that occurs from neglectful or improper use of products, including, but not limited to, damage that occurs as a result of usage with incompatible voltage, regardless of whether the product was used with a converter or adapter. See Safety Instructions in the Chefman® User Guide for information on proper use of product;

- **Poor Maintenance**

General lack of proper care. We encourage you to take care of your Chefman® products so that you may continue to enjoy them. Please see cleaning and maintenance directions in the Chefman® User Guide for information on proper maintenance;

- **Commercial Use**

Damage that occurs from commercial use;

- **Normal Wear and Tear**

Damage or degradation expected to occur due to normal use over time;

- **Altered Products**

Damage that occurs from alterations or modifications by any entity other than Chefman® such as the removal of the rating label affixed to the product;

- **Catastrophic Events**

Damage that occurs from fire, floods, or natural disasters; or

- **Loss of Interest**

Claims of loss of interest or enjoyment.





Terms & Conditions

[For product information, please visit us at Chefman.com.](http://Chefman.com)

EXCEPT WHERE SUCH LIABILITY IS REQUIRED BY LAW, THIS WARRANTY DOES NOT COVER, AND CHEFMAN® SHALL NOT BE LIABLE FOR, INCIDENTAL, INDIRECT, SPECIAL, OR CONSEQUENTIAL DAMAGES, INCLUDING WITHOUT LIMITATION, DAMAGE TO, OR LOSS OF USE OF THE PRODUCT, OR LOST SALES OR PROFITS OR DELAY OR FAILURE TO PERFORM THIS WARRANTY OBLIGATION. THE REMEDIES PROVIDED HEREIN ARE THE EXCLUSIVE REMEDIES UNDER THIS WARRANTY, WHETHER BASED ON CONTRACT, TORT OR OTHERWISE.





Warranty Registration

What do I need to register my product?

- Contact Information
- Model Number (see example below)
- Proof of Purchase (online confirmation, receipt, gift receipt)
- Date Code (see example below)
- Access Code (see example below)

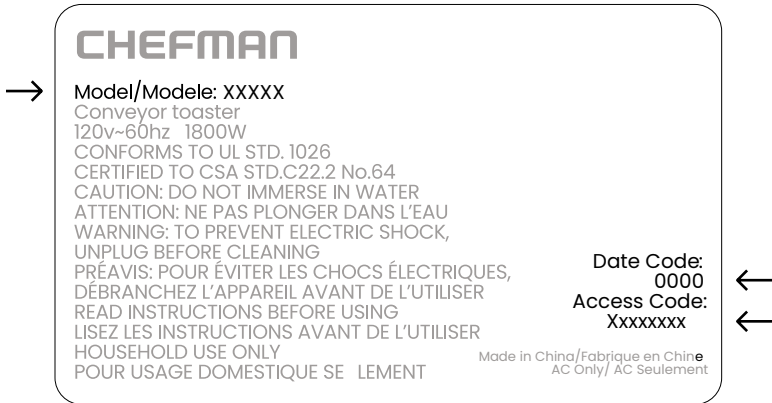

NOTE: Label depicted here is an example.

Please see label on your product for actual model/date code/access code.

How do I register my product?

All you need to do is fill out a simple Chefman® registration form. You can easily access the form in one of the two ways listed below:

- Visit Chefman.com/register.
- Scan the QR code to the right to access site.





CHEFMAN.

**Family-Sized Glass Top
Warming Tray**

RJ22TCV3BKUG041524

Chefman® is a registered trademark of RJ Brands, LLC.