

Sur la table

AIR FRYER

13-QT MULTIFUNCTIONAL KITCHEN APPLIANCE

OWNER'S MANUAL



Scan here for bonus recipes and to watch how-to videos that will help you make the most of your air fryer. or go to www.mcappliances.us

MODEL: SLT-1807

BEFORE USE, PLEASE READ AND FOLLOW ALL IMPORTANT SAFEGUARDS, WARNINGS, CAUTIONS AND OPERATING INSTRUCTIONS.



Congratulations! You now own an incredibly versatile, convenient and powerful countertop cooker.

Our air fryer with accessories gives everyone a healthier, faster and easier way to enjoy the foods they love.

To get the most out of your air fryer, please read through this owner's manual.

Enjoy!

Sur la table

WHAT'S IN THE BOX

7ⁱⁿ1
MULTI-FUNCTIONAL
AIR FRYER

10
ACCESSORIES

A
AIR FRYER

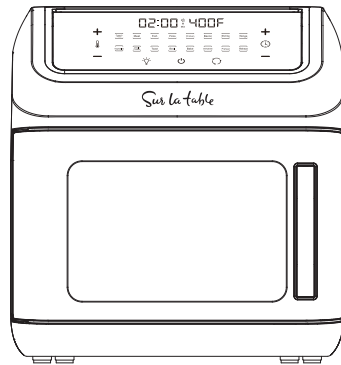

Air fry • Rotisserie
Bake • Broil
Reheat • Preheat
Dehydrate

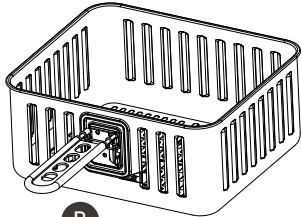

B
AIR FRY BASKET

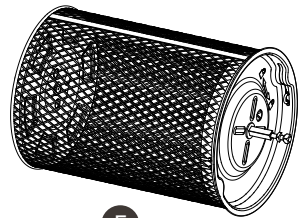

F
ROTATING DRUM BASKET

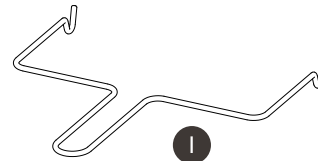

I
ROTISSERIE HANDLE

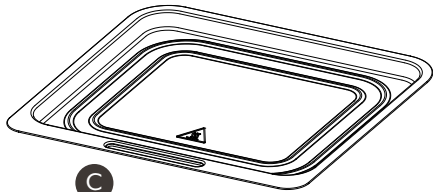

C
DRIP TRAY

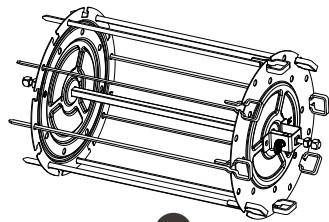

G
(8) SKEWERS & RACK

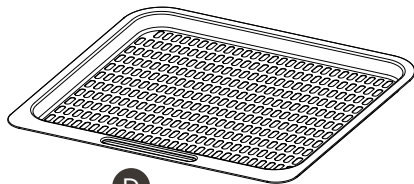

D
(2) AIR FRY TRAYS

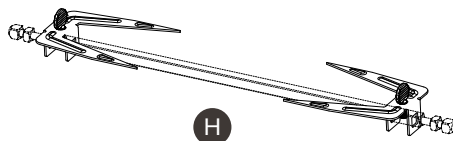

H
SKEWER FORKS

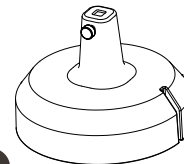

E
ROTISSERIE STAND



ALL ACCESSORIES ARE DISHWASHER SAFE

IMPORTANT SAFEGUARDS

READ THESE INSTRUCTIONS CAREFULLY AND RETAIN THEM FOR FUTURE USE. IF THIS PRODUCT IS PASSED TO A THIRD PARTY, THEN THESE INSTRUCTIONS MUST BE INCLUDED. WHEN USING ELECTRICAL APPLIANCES, BASIC SAFETY PRECAUTIONS SHOULD ALWAYS BE FOLLOWED TO REDUCE THE RISK OF FIRE, ELECTRIC SHOCK, AND/OR INJURY TO PERSONS INCLUDING THE FOLLOWING:

- Read all instructions.
- Do not touch hot surfaces. Use handles or knobs. Use mitts or potholders.
- To protect against electric shock, do not place cord, plugs, or appliance in water or other liquid.
- Close supervision is necessary when any appliance is used by or near children.
- Unplug from outlet when not in use and before cleaning. Allow to cool before putting on or taking off parts, and before cleaning the appliance.
- Do not operate any appliance with a damaged cord or plug or after the appliance malfunctions or has been damaged in any manner. Return appliance to an authorized service facility for examination, repair or adjustment.
- The use of an accessory not evaluated for use with this appliance may cause injuries.
- Do not use outdoors.
- Do not let cord hang over edge of table or counter or touch hot surfaces.
- Do not place on or near a hot gas or electric burner, or in a heated oven.
- Extreme caution must be used when moving an appliance containing hot oil or other hot liquids.
- To disconnect, turn any control to "off" then remove plug from wall outlet.
- Do not use appliance for other than intended use.
- This product is for household use only.
- Do not immerse in water.
- Avoid contacting moving parts.

CAUTION: RISK OF ELECTRICAL SHOCK! Cook only in removable container.

- This appliance has a polarized plug (one blade is wider than the other), to reduce the risk of electric shock, this plug will fit outlet only one way. If the plug does not fit fully in the outlet, reverse the plug. If it still does not fit, contact a qualified electrician. Do not modify the plug in any way.
- Be sure that handles are assembled and fastened properly.
- Only the included cord should be used.
- Leave at least 6" (15 cm) of space in all directions around the product to ensure sufficient ventilation.
- To prevent food contact with the heat element, do not overfill the rotating basket.
- When in operation, hot air is released through the air outlet on the back of the product. Keep hands and face at a safe distance from the air outlet. Never cover the air outlet. Can be hot and should not be touched without precautions.

SAVE THESE INSTRUCTIONS



GETTING TO KNOW YOUR 13 QT AIR FRYER APPLIANCE

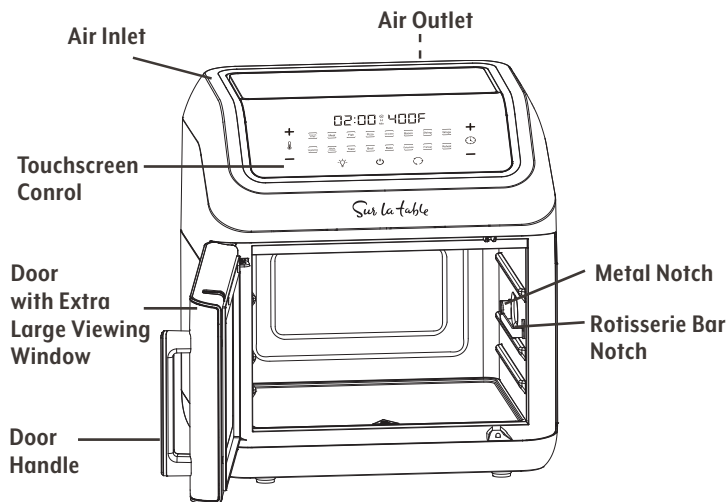

Product may vary slightly from illustration.

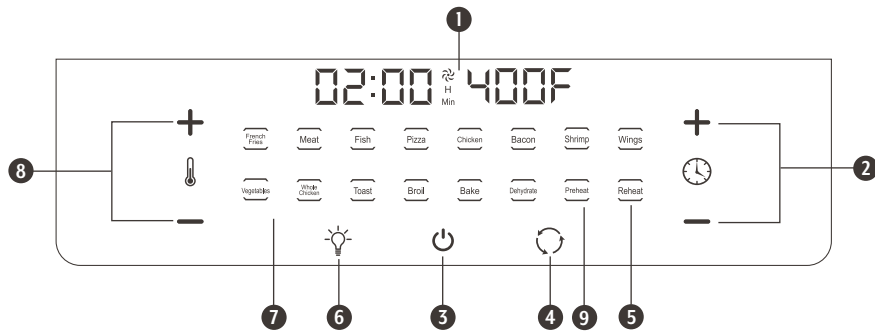

NAME	DETAIL	FUNCTION
1	Display	Displays time/temperature
2	⌚ +/-	Increase/decrease cooking time
3	⏻	Switch on/off
4	🔄	Rotation function (for accessories F/G/H)
5	🔥	Reheat (pre-set)
6	💡	Light on/off
7	Pre-sets	Pre-set programs
8	🌡 +/-	Increase/decrease temperature
9	🔥	Preheat

TOUCHSCREEN CONTROL



Figure 3

POWER (⏻) button. Press the POWER button to begin. The POWER (⏻) button will also initiate cooking once the TIME and TEMPERATURE are set or adjusted. Pressing the POWER button again will turn the appliance off.

DIGITAL DISPLAY. While in operation, the Air Fryer's set TEMPERATURE and remaining TIME are displayed on the digital display at the same time. When the time counts down to 00:00, "OFF" will appear and 3 beeps sound as the Air Fryer Appliance turns OFF automatically.

16 PRESET MENU ICONS. To use any of the 16 preset menu options, simply press the desired preset icon. (French Fries, Meat, Fish, Pizza, Chicken, Bacon, Shrimp, Wings, Vegetables, Whole Chicken, Toast, Broil, Bake, Dehydrate, Preheat, Reheat)

LIGHT (💡) button. Press to turn the LIGHT on or off. While ON, the button will flash. Press the flashing LIGHT (💡) button to turn the light OFF. NOTE: Any time the appliance's door is opened, the light will illuminate. When the appliance's door is properly closed, the light will turn OFF.

The appliance's light can be turned on and off during the cooking process. Light turns off once the cooking time has ended and air fryer has turned off automatically.

FAN (🌀) Icon. The white convection fan (🌀) will flash when the Air Fryer is ON, as "OFF" appears on the digital display, until 5 beeps sound and the Air Fryer Appliance turns OFF.

TIME (⌚) button. Press to change the TIME on the digital display. The (+) and (-) symbols enable you to add or decrease cook TIME 1 minute at a time. Long press the (+) or (-) symbol to increase or decrease time at 5 minute increments.

NOTE: Cooking time can be added or reduced while cooking is in progress.

TEMPERATURE (🌡) button. Press to change the TEMPERATURE on the digital display. The (+) and (-) symbols enable you to add or decrease cooking TEMPERATURE 5°F at a time. NOTE: Cooking temperature can be increased or reduced while cooking is in progress. To switch between Fahrenheit and Celsius, press the up and down temperature arrows for 3 seconds.

ROTISSERIE (🍷) button. When the food is securely fastened to the rotisserie assembly and the rotisserie bar is securely in place, press to turn the Rotisserie ON. The rotisserie bar will begin to rotate, and the ROTISSERIE icon will flash. Press the flashing ROTISSERIE (🍷) button again to turn rotation OFF.

PREHEAT Button. Once you have selected your desired cooking preset, time, and temperature, you can press preheat to preheat the air fryer. When the air fryer is preheated, it will beep and ADD FOOD will appear on the digital display. Add food, close the door, and cooking will begin after 5 seconds of inactivity.

MENU CHART

	MENU	DEFAULT TEMP (°F)	ADJUSTABLE TEMP (°F)	TIME (MIN)	ADJUSTABLE TIME (MIN)
1	French Fries	400	150~400	20	1~90
2	Meat	350	150~400	30	1~90
3	Fish	325	150~400	20	1~90
4	Pizza	350	150~400	8	1~90
5	Chicken	370	150~400	25	1~90
6	Bacon	320	150~400	8	1~90
7	Shrimp	380	150~400	3	1~90
8	Wings	400	150~400	20	1~90
9	Vegetables	300	150~400	10	1~90
10	Whole Chicken	350	150~400	35	1~90
11	Toast	400	150~400	3	1~90
12	Broil	400	150~400	6	1~60
13	Bake	320	150~400	30	1~90
14	Dehydrate	120	90~170	8:00	1:00~24:00
15	Preheat	350	150~400	5	1~90
16	Reheat	280	150~400	6	1~90
17	Default	380	150~400	15	1~90

NOTE: Rotisserie can be used along with the 16 presets or at the default temperature of 380°F for 15 mins. When using the Whole Chicken preset, the rotisserie is automatically turned on.

CAUTION: RISK OF FIRE! Never use a cooking container filled with cooking oil or other hot liquids

CAUTION: RISK OF BURNS! The product gets hot during and after use. Do not touch hot surfaces with bare hands. Wear oven mitts during use.

START COOKING

Start Cooking Without Preheating Air Fryer

STEP 1 Place food in the appropriate accessory and carefully insert it in the air fryer.

STEP 2 Select the preset cooking function.

STEP 3 Adjust time and temperature to match your recipe

STEP 4 Cooking will automatically begin after 5 seconds of inactivity

Start Cooking Using the Preheat Function

STEP 1 Select the preset cooking function.

STEP 2 Adjust time and temperature to match your recipe

STEP 3 Press the Preheat button

STEP 4 When the air fryer is preheated, it will beep 3 times and the display will instruct to ADD FOOD

STEP 5 Carefully insert food into the air fryer

STEP 6 Cooking will automatically begin after 5 seconds of inactivity

LIGHT

Tap the  key (6) to switch the built-in light on and off.

ROTATION

This function slowly rotates the rotating basket (F), skewers rack (G) or the rotisserie forks (H).

- Open the door. The light in the appliance switches on.
- Using the handle tool (I), place the shaft of the accessory (F, G or H) into the left coupler (fig. 1) and place the right end on the bracket slot (fig. 2)

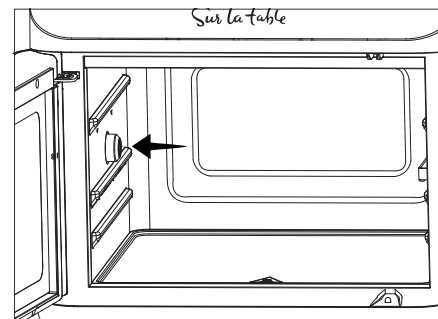

Figure 1

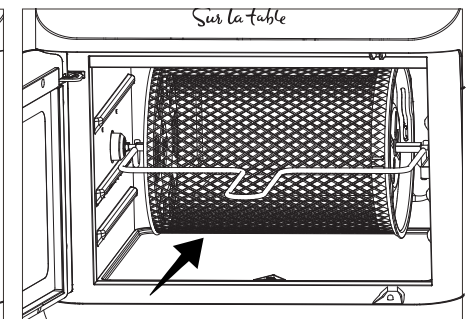



Figure 2

- Remove the handle tool (I) from the appliance.
- Close the door.
- To switch the rotation function on and off, tap the key ().
- After cooking, use the handle tool (I) to remove the accessory (F, G, H).
- Lift the handle tool (I) and the accessory (F, G, H) carefully out of the appliance.

USING THE ACCESSORIES

	NAME	FUNCTION
B	Frying Basket	Use to fry larger quantity of foods. Always place on the drip tray (C) inserted into the lowest rail.
C	Drip Tray	Use to collect oil and other residues during frying process.
D	Frying Tray	Use to dehydrate, fry crispy snacks and reheat food.
E	Rotisserie Stand	Use to place the accessory (F, G, H) when hot after cooking. CAUTION: Do not place the stand inside the oven.
F	Rotating Basket	Use to fry food more evenly. Use to prepare french fries and roasted dry fruits.
G	Skewers Rack	Use to air fry / barbeque meat/fish/vegetables.
H	Rotisserie Forks	Use to air fry whole chicken/large pieces of meat. Force shaft lengthwise through the meat.*
I	Handle Tool	Use to place and remove the accessory (F, G, H).

Make sure the whole chicken/large pieces of meat fit into the appliance without making contact with the heating elements or side walls or door of the appliance when rotating.

CAUTION: RISK OF INJURY! Skewers and forks have sharp edges. Handle with care.

Using The Frying Basket **B**

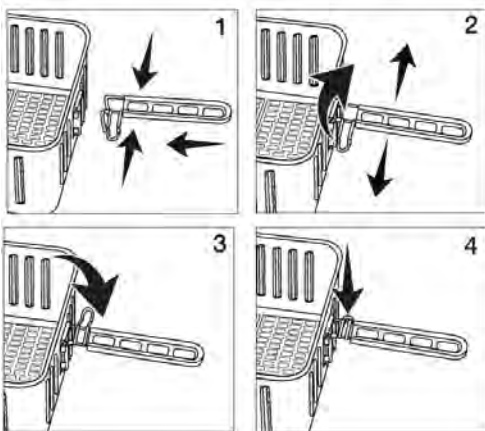

Attach Handle to Frying Basket

1. Gently press the sides of the handle together
2. Insert ends in slots on the frying basket from the top and release in place
3. Rotate clip on top of handle until you hear a click

Remove Handle from Frying Basket

1. Flip right side of clip up off of handle and rotate underneath
2. Gently press the sides of the handle together and lift off of basket

Using the Skewer Forks **H**

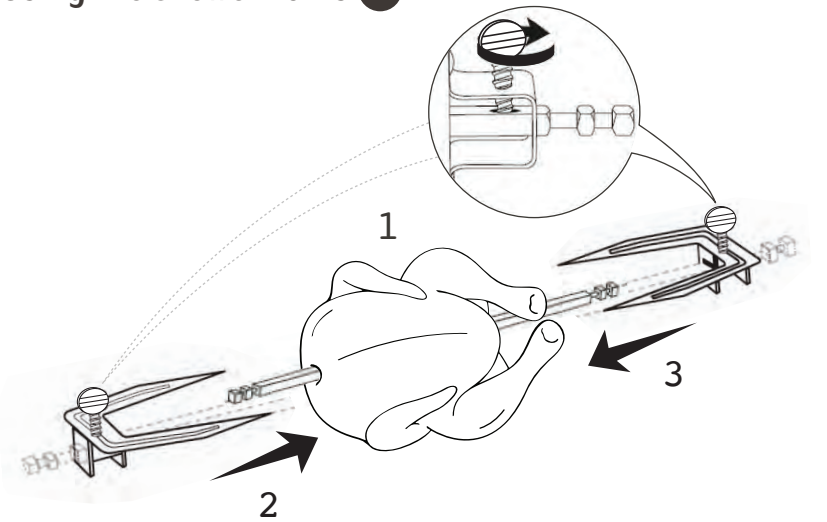

Using the Skewers Rack **G**

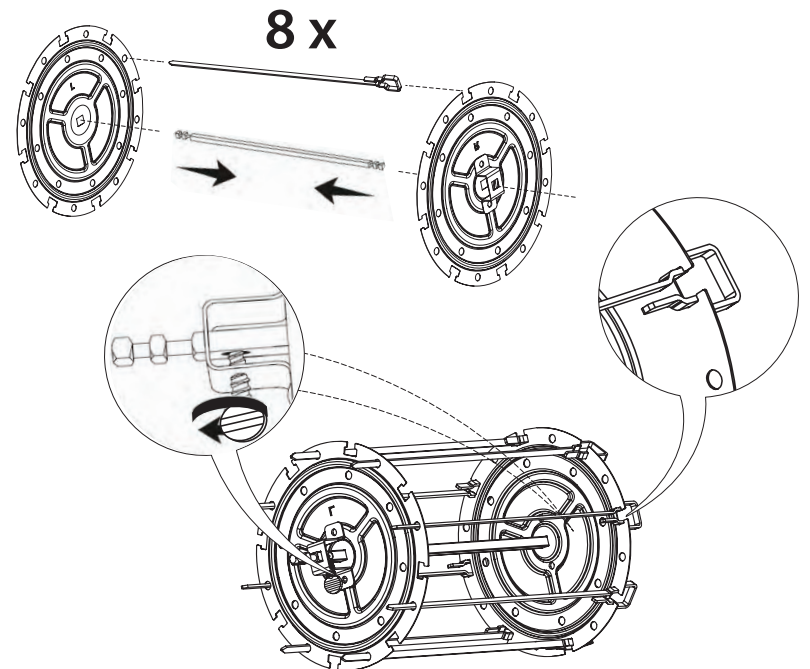

Using The Rotating Basket **F**

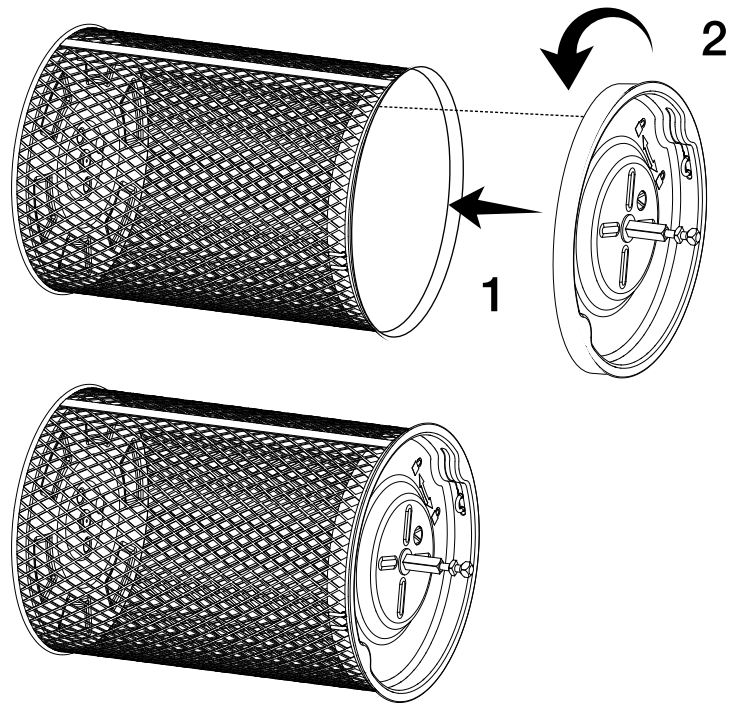

Insert Rotisserie into Appliance **F G H**

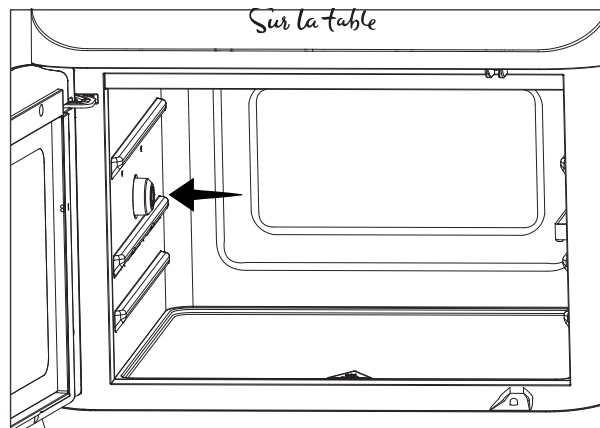

Hold the assembled Rotisserie Rod at a slight angle with the right side higher than the left side and insert the left side of the Rod into the Rotisserie connection inside the appliance.

Using The Stand **E**

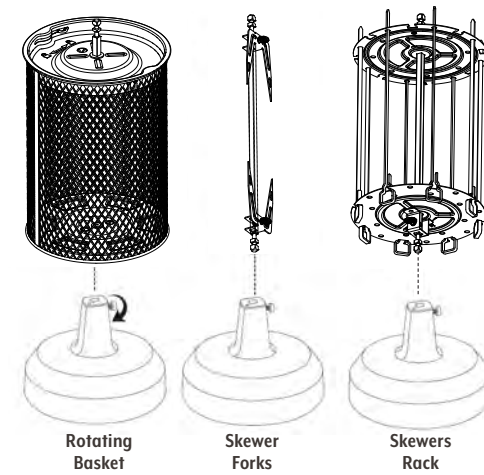

Using the Rotisserie Handle **I**

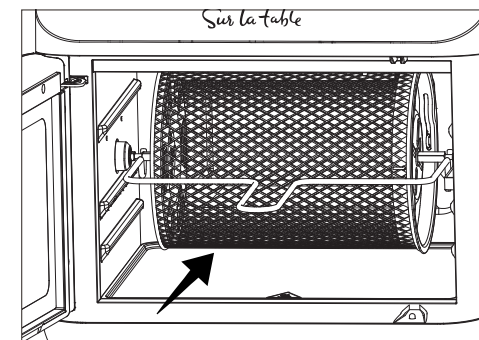

Placing The Frying Trays

Place the frying trays (D) on one of the 2 rails inside the appliance. Place on the lower rails for lower temperature and on higher rails for higher temperature.

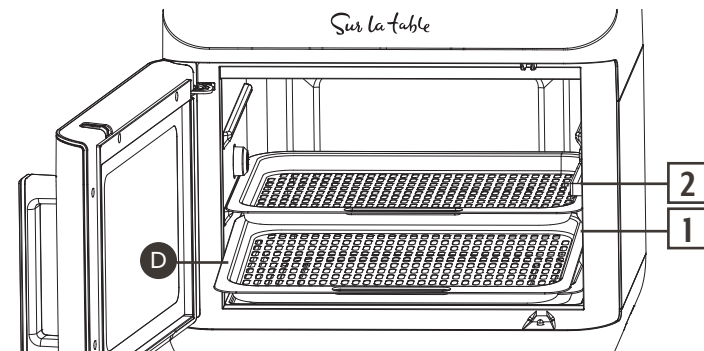

COOKING CHART

Notice: For best results, some foods require cooking through on a low temperature (par-cooking) before air frying.

NOTE: Suggested cooking times are recommendations based on the types of foods. Times will vary depending on the size and quantity of each portion.

NOTE: These suggested cooking times are based on NOT using the preheat function.

FOOD TYPE	MIN-MAX	TEMP	TIME	TIP	
Thin frozen fries	1.5-3 cups (330 - 660 g)	400 °F (200 °C)	15-20 mins		
Thick frozen fries	1.5-3 cups (330-660 g)		15-20 mins		
Homemade fries	1.5 - 3.5 cups (330-770 g)	400 °F (200 °C)	10-16 mins		
Homemade potato wedges	1.5-3.5 cups (330-770 g)	360 °F (182 °C)	18-22 mins	Add 1/2 tbsp oil	
Homemade potato cubes	1.5-3.5 cups (330-770 g)	360 °F (182 °C)	12-18 mins	Add 1/2 tbsp oil	
Hash browns	1 cup (220 g)	360 °F (182 °C)	15-18 mins	Add 1/2 tbsp oil	
Potato gratin	2 cups (440 g)	360 °F (182 °C)	15-18 mins		
Steak	1/4-1.1 lbs (110-500 g)	360 °F (182 °C)	8-12 mins		
Pork chops		360 °F (182 °C)	10-14 mins		
Hamburger		360 °F (182 °C)	7-14 mins		
Sausage roll		400 °F (200 °C)	13-15 mins		
Chicken drumsticks		360 °F (182 °C)	18-22 mins		
Chicken breast		360 °F (182 °C)	10-15 mins		
Spring rolls		1/4 - 3/4 lbs (110-340 g)	360 °F (182 °C)	15-20 mins	
Frozen chicken nuggets		1/4-1.1 lbs (110-500 g)	400 °F (200 °C)	10- 15 mins	
Frozen fish sticks	400 °F (200 °C)		6-10 mins		
Mozzarella sticks	360 °F (182 °C)		8-10 mins		

FOOD TYPE	MIN-MAX	TEMP	TIME	TIP
Stuffed vegetables	1/4- 1.1 lbs (110-500g)	320 °F (160 °C)	10 mins	
Cake	1.25 cups (275 g)	360 °F (182 °C)	20 - 25 mins	Use baking tin
Quiche	1.5 cups (330 g)	360 °F (182 °C)	20 - 22 mins	Use baking pan
Muffins	1.25 cups (275 g)	400 °F (200 °C)	15-18 mins	Use baking pan
Sweet snacks	1.5 cups (330 g)	320 °F (160 °C)	20 mins	Use baking pan
Frozen onion rings	1 lb (450 g)	400 °F (200 °C)	15 mins	

Adjusting The Temperature

Press the +/- keys (8) to adjust the temperature.

Notice: The temperature can be adjusted at any time before and during the cooking process.

To switch between Fahrenheit and Celsius, press the up and down temperature arrows for 3 seconds.

Adjusting The Time

Press the +/- keys (2) to adjust the time.

Notice: The time can be adjusted at any time before and during the cooking process.

Notice: Check the doneness of the food either by cutting a big piece open to check if it is cooked through or using a food thermometer (not included) to check the internal temperature. Refer to suggested minimum internal temperatures:

FOOD TYPE	MINIMUM INTERNAL TEMPERATURE
Beef, Pork, Veal and Lamb	145 °F (62.8 °C) (rest for at least 3 minutes)
Ground Meats	160 °F (71.1 °C)
Poultry	165 °F (73.9 °C)
Fish and Shellfish	145 °F (62.8 °C)



COOKING TIPS

- **FOR A CRISPY SURFACE**, pat the food dry then lightly toss or spray with oil to encourage browning.
- To estimate **FRYING TIME FOR FOODS THAT ARE NOT MENTIONED IN THE COOKING CHART**, set the temperature 10 °F (6 °C) lower and the timer with 30% - 50% less time than what is stated in the recipe for traditional oven cooking.
- **WHEN FRYING HIGH FAT FOODS** (e.g. chicken wings, sausages) pour away excess oils in the drip tray (C) in between batches to avoid the oil smoking.

CLEANING AND MAINTENANCE

CAUTION: Risk of electric shock! To prevent electric shock, unplug the product before cleaning.

CAUTION: Risk of burns! The product is hot during and after cooking. Do not touch the air inlet, air outlet or the accessories with bare hands. Let the product cool down for 30 mins before cleaning.

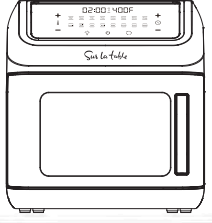
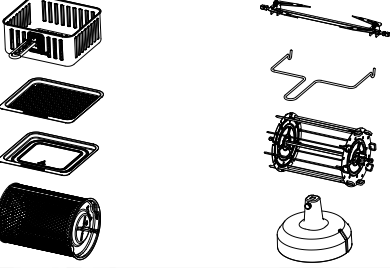
			
	✗	✗	✓
	✓	✓	✓

CAUTION: Risk of electric shock! During cleaning do not immerse the electrical parts of the product in water or other liquids. Never hold the product under running water.

- Wipe the product with a soft, slightly moist cloth.
- Dry the product and the accessories after cleaning.
- Never use corrosive detergents, wire brushes, abrasive scourers, metal or sharp utensils to clean the product.

Storage

- Store the product in its original packaging in a dry area. Keep away from children and pets.

Maintenance

- Any other servicing than mentioned in this manual should be performed by a professional repair center.

TROUBLESHOOTING

PROBLEM	SOLUTION
Product does not switch on.	Check if the power plug is connected to the power outlet. Check if the power outlet works.
The product shuts down suddenly due to overheating.	Unplug the product and let it cool down for at least 30 minutes.
Food not cooked.	The rotating basket is overloaded. Use smaller batches for more even frying. The temperature is set too low. Increase temperature and continue cooking.
White smoke coming out.	Excessive oil is being used. Accessories have excess oil residue from previous cooking.

ERROR CODES

CODE	PROBLEM	SOLUTION
E1	Broken circuit of the thermal sensor.	(877) 246-0990
E2	Short circuit of the thermal sensor.	(877) 246-0990

1 YEAR LIMITED WARRANTY

Customer Service:

(877) 246-0990

ApplianceSupport@monchateau.us

Sur la table

MULTIFUNCTIONAL
AIR FRYER

13 QUART / 12.3 LITER

Customer Service:

(877) 246-0990

ApplianceSupport@monchateau.us

MODEL: SLT-1807