

# KEURIG®

## K·Café® Barista Bar

### Use & Care Guide

Get the most from your  
new Keurig® brewer



# Button Overview

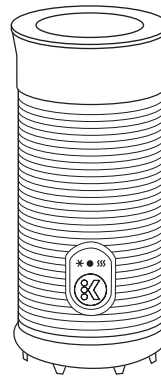
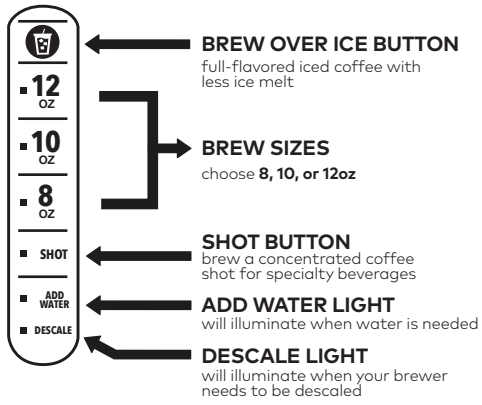

## HOT & COLD

standalone frother will produce creamy, velvety froth for your favorite specialty beverages

**How to Froth Like a Pro:** A few simple tips to help ensure a fantastic frothing experience every time.

### Fresher is Better

Using fresh milk delivers the richest, frothiest foam possible. Opened milk will still froth, but may lose effectiveness over time as the fats inside break down.

**Milk Matters!** Different types of milk produce different results. Depending on which milk you use, here's what you can expect:

- **Fat-Free/Skim Milk:** Easy to froth, it creates a light, airy foam.
- **2% Milk:** Easy to foam like skim milk, but with a creamier consistency.
- **Whole Milk:** Higher fat content creates the richest-tasting foam.
- **Lactose-Free Milk:** Less reliable, due to its different properties.
- **Dairy Alternatives:** Results will vary depending on type; loses its bubbles more quickly than dairy milk.

### Not All Brands Are the Same

Even individual brands of milk can froth differently, so experiment with different brands to see what works best.

## Before You Brew

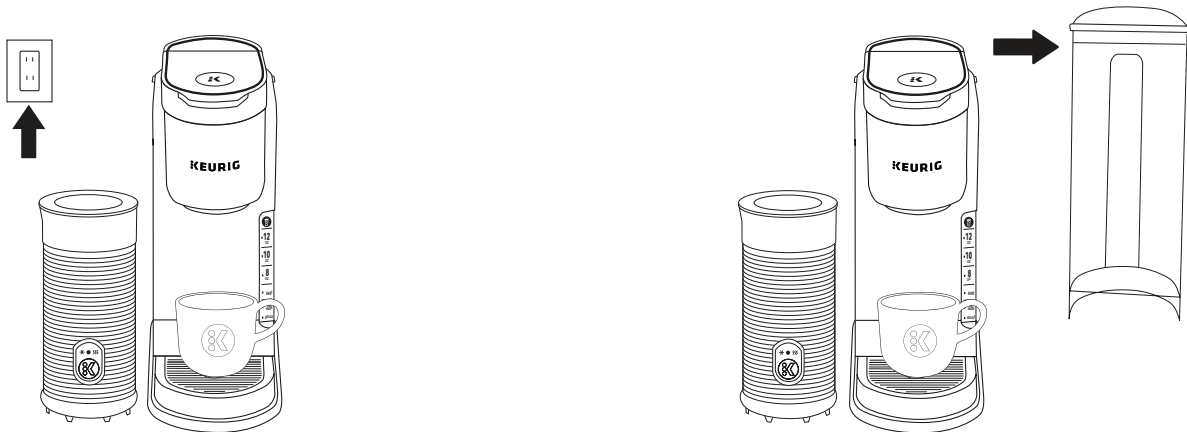

### 1 Plug & Place

Remove packing tape from brewer and frother. Plug each into an outlet.

Place a large mug (10oz minimum) on the drip tray.

### 2 Rinse & Fill

Remove the water reservoir lid, then lift the reservoir straight up to remove it. If you have a Keurig® Water Filter (sold separately), install it now. Refer to your Water Filter Starter Kit for instructions.

Rinse reservoir with fresh water and fill to the **MAX FILL** line.

Replace water reservoir, making sure the tank is seated properly in the base. Replace lid.

**NOTE:** Do not use distilled water.



### 3 Clean the Frother

Remove the lid and whisk from inside the frother. Wash the interior of the frother, lid, and whisk with warm, soapy water. Dry all parts thoroughly using a soft, nonabrasive cloth, then reassemble.

**NOTE:** Frother is not dishwasher safe. Do not submerge frother in water. Only use nonabrasive cleaning materials to prevent damage to the inner surface of the frother. Dry interior of frother and base with a soft cloth after cleaning.

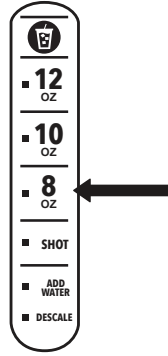

### 4 Cleansing Brew

Lift and lower the handle. Do not insert a K-Cup® pod. The brewer will power on automatically. The 3 cup sizes will blink. Press the **8oz** button to start a cleansing brew. Pour the hot water into the sink. Do not remove the water reservoir or lift the handle once the brew button has been pressed until the brew has completed.

**The one-time setup process is now complete, and you are ready to brew!**

## Hot and Cold Frother

### INSTRUCTIONS

1. Fill the frother with your milk of choice, staying within the **MIN/ MAX** line.
2. Plug in the frother.
3. Toggle between the froth settings using the **K** button:

**Hot Froth:** Single press and the LED will illuminate red

**Cold Froth:** Double press and the LED will illuminate blue

4. The frother will immediately begin frothing when on desired setting. Frothing is complete when the frother light is no longer illuminated.
5. Pour your fresh froth over your coffee and enjoy!

## Make Your First Hot or Iced Latte

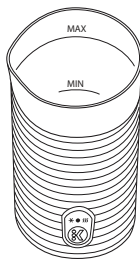

### 1. Froth Milk

Remove lid and add milk to the **MAX** line marked in the frother (for cappuccino, fill to **MIN** line). Replace the lid and place the frother on the frother base.

Press the **K** button on the frother one time to activate the hot froth setting.

The LED will stay illuminated while frothing. Frothing is complete when the LED turns off.

**To Make It Iced:** Press the **K** button twice in rapid succession to activate the **Iced Setting** on your frother.

**CAUTION:** Frother is not microwave or dishwasher safe.

**NOTE:** Do not under- or overfill frother. Do not operate before adding milk.

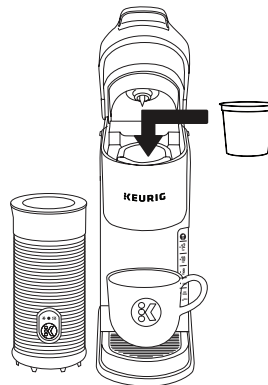

### 2. Brew

While frothing, lift the handle of your brewer and place a K-Cup® pod in the K-Cup® pod holder. Lower the handle completely to close the lid and place a mug on the drip tray. The brew selections will blink. Press the **SHOT\*** button.

**To Make It Iced:** Place ice in your cup and press the **BREW OVER ICE** button.

**NOTE:** Do not use a glass mug for the BOI setting.

**CAUTION:** While brewing, there is extremely hot water in the K-Cup® pod holder. To avoid injury, do not lift the handle during the brew process.

**Do not remove the foil lid on the K-Cup® pod.**

\*Can also brew any cup size, but **SHOT** is recommended for coffeehouse beverages.

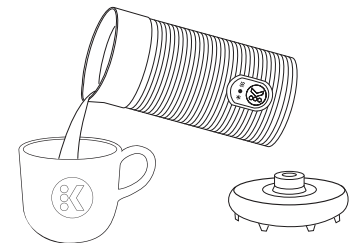

### 3. Create Your Latte

Once the brew is completed, dispose of the used K-Cup® pod. Remove the frother from the base.

Remove the lid and pour the frothed milk over your coffee.

**NOTE:** Clean frother immediately after use. For cleaning instructions, see Caring For Your Frother section in this guide.

# Brewer Features

**HOT AND COLD FROTHER:** Use any fresh milk or dairy alternative, like oat, almond, or soy.

**BREW OVER ICE:** Brews by starting hotter to extract full flavor, then cooling down for less ice melt.

**SHOT:** Use any K-Cup® pod to brew a concentrated 2oz coffee shot.

**FAST & FRESH-BREWED:** Coffee made in minutes.

**BACK-TO-BACK BREWING:** Immediately brew a second cup; no need to wait for reheating.

**TRAVEL MUG FRIENDLY:** Accommodates travel mugs up to 7.25" tall.

**SIMPLE BUTTON CONTROLS:** Just insert any K-Cup® pod and use the button controls to brew a delicious cup.

**MAINTENANCE ALERT:** Reminds you to descale after every 500 brews.

**NOTE:** Regular descaling enhances the taste of your coffee and the long-term performance of your brewer.

**COMPATIBLE WITH THE MY K-CUP® UNIVERSAL REUSABLE COFFEE FILTER:** Brew your own ground coffee (sold separately).

**AUTO OFF:** Automatically turns your brewer off 5 minutes after the last brew for energy savings, but will be ready to brew as soon as it is powered on again.

**HIGH ALTITUDE BREWING:** While holding the brewer handle up, push down slowly on the K-Cup® pod in the pod holder until the bottom of the K-Cup® pod is punctured by the exit needle.

**HIGH ALTITUDE:** To ensure your coffee maker works properly at higher altitudes (5,000 feet), please enable the High Altitude Brewing Mode on your coffee maker.

1. Begin with the brewer plugged in and powered off.
2. Press and hold the **BREW OVER ICE** button and **10oz** button for 3 seconds. The **12oz** button will illuminate to confirm that the High Altitude Mode has been enabled.

High Altitude Mode will remain enabled until steps 1-2 are repeated and the **8oz** light turns on to confirm that the High Altitude Brewing Mode is disabled.

# Caring For Your Brewer

Regular cleaning keeps your brewer running smoothly. Always be sure to turn off and unplug your brewer before cleaning.

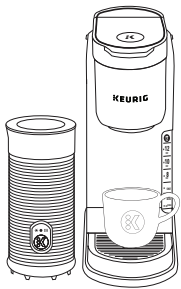

## Brewer Exterior

Keep your Keurig® brewer looking its best by cleaning the exterior from time to time. Just clean with a damp, soapy, lint-free, nonabrasive cloth. Never immerse the brewer in water or other liquids.

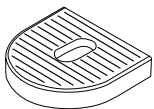

## Drip Tray

The drip tray overflow should be emptied and cleaned occasionally. To remove, lift up off brewer base, keeping it level to avoid spilling. Rinse and clean with a damp, soapy, lint-free, nonabrasive cloth. Hand-wash only.

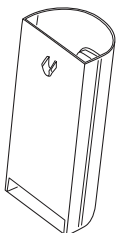

## Water Reservoir

The water reservoir should be cleaned periodically by wiping the inside of the reservoir and underside of the lid with a damp, nonabrasive, lint-free cloth. Do not dry the inside of the water reservoir with a cloth, as lint may remain. Allow the reservoir to dry completely. Hand-wash only.



## Care For Your Frother

Clean immediately after each use and before first use.

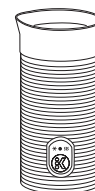

## To Clean:

1. Remove frother from the base, remove silicone ring from lid, and remove the whisk from inside the frother.
2. Wash the silicone ring, lid, and whisk with warm, soapy water.
3. Clean the interior of the frother with soap and rinse with warm water. Use a soft, nonabrasive cloth or sponge to prevent damaging the inner coating.
4. Wipe the exterior with a soft, damp cloth.
5. Dry all parts thoroughly and reassemble for next use.

**NOTE:** Frother is not dishwasher safe. Do not submerge frother in water. Only use nonabrasive cleaning materials to prevent damage to the inner surface of the frother.

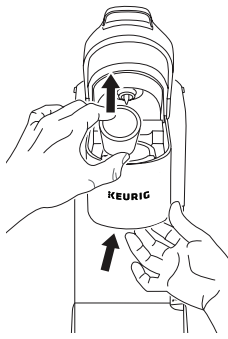

### K-Cup® Pod Holder

To remove the K-Cup® pod holder from the brewer, lift the handle and grasp the top of the K-Cup® pod holder with one hand while pushing up on the bottom of the K-Cup® pod holder from underneath with the other until it releases. After cleaning, align the K-Cup® pod holder with the opening, using the two front ribs as a guide, and snap into place from the top.

**CAUTION:** There are sharp needles that puncture the K-Cup® pod above the K-Cup® pod holder and in the bottom of the K-Cup® pod holder. To avoid risk of injury, do not put your fingers in the K-Cup® pod holder.

**NOTE:** Always remove and dispose of the used K-Cup® pod after brewing.

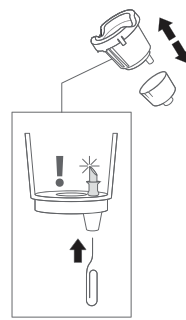

### Exit Needle

Remove the pod holder assembly and detach the funnel. Locate the exit needle on the inside bottom of the K-Cup® pod holder. Insert a straightened paper clip into the exit needle to loosen any coffee grounds.

### Entrance Needle

Lift the brewer handle and locate the entrance needle on the underside of the lid. To clean the holes in the needle, hold the brewer handle in the upward position; with your other hand, carefully insert a straightened paper clip into all the holes. Gently move it around to loosen any coffee grounds. Lower the handle completely and run a cleansing brew two times. Do not insert a K-Cup® pod.

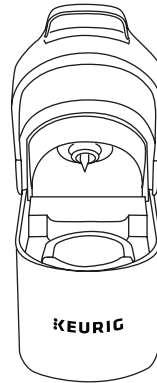

### Funnel

Washing the funnel ensures a fresh beverage experience. The funnel should be washed regularly and can be removed from the K-Cup® pod holder by pulling on it until it pops off. To replace it, orient the snaps to the indent and just snap it back onto the K-Cup® pod holder.

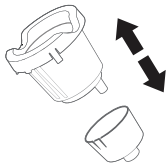

## Regular Maintenance

For great-tasting coffee, keep your brewer running at peak performance by following the recommended maintenance schedule:

Frequency	Product	Benefit
Weekly	Keurig® Rinse Pods	Weekly cleaning with Keurig® Rinse Pods helps reduce flavor carryover between brews
Every two months	Keurig® Water Filters	Keep your water fresh and help remove impurities
Every three months or when the Descale notification turns on*	Keurig® Descaling Solution Keurig® Descale Pouch**	Eliminate mineral buildup to preserve the long-term health of your coffee maker

\*To turn off Descale notification, follow the full descaling procedure as outlined in this guide.

\*\*Please visit [www.keurig.com/descale](http://www.keurig.com/descale) for instructions on using the Descale Pouch.

If the brewer has been in storage or hasn't been used in days, run a cleansing brew before brewing your beverage. Periodically **hand-wash** the water reservoir and lid and drip tray with warm, soapy water and rinse clean.

**CAUTION:** Parts are not dishwasher safe.

**NOTE:** Do not dry the inside of the water reservoir with a cloth, as lint may remain.

# Descaling Procedure

**NOTE:** The full descaling procedure must be completed to turn off the Descale light.

**You will need:** A large ceramic mug (10oz minimum), fresh water, Keurig® Descaling Solution, and access to a sink.

Do not use a paper cup. Ensure that there is no beverage pod in the K-Cup® pod holder. The descaling procedure takes approximately 20 minutes.

## STEP 1: Prepare the Brewer

Pour the entire bottle of Keurig® Descaling Solution into the empty water reservoir. Then fill the empty bottle with water and pour into the water reservoir.

### Do not insert a K-Cup® pod.

Place a large mug on the drip tray.

## STEP 2: Descaling the Brewer

To activate Descale Mode, begin with the brewer plugged in and powered off, then press and hold the **8oz** and **12oz** buttons together for 3 seconds.

When flashing, press the **12oz** button to start the descaling process. Once the brew is complete, pour the hot liquid into the sink. Continue to brew until the **ADD WATER** light illuminates.

## STEP 3: Fresh Water Rinse

Empty and rinse the water reservoir and refill to the **MAX FILL** line with fresh water. When flashing, press the **12oz** button to start the rinsing process.

Once the brew is complete, pour the hot liquid into the sink.

Continue to brew until the Descale notification turns off.

The brewer has now exited Descale Mode and is ready for use!

**NOTE:** The cleaning action of Keurig® Descaling Solution may result in a “foam” dispensed from the brewer. This is natural, as the solution is reacting with the scale inside. For a brewer that is heavily scaled, the brewer may not fill properly after the descaler is added. If this occurs, you may see little to no output dispensed, followed by the sound of air blowing out. If this occurs:

- Turn off and unplug the brewer.
- If there is Keurig® Descaling Solution in the water reservoir, discard the contents, rinse the water reservoir thoroughly, and refill with water.
- Plug the brewer back in, power on, and repeat the Step 3 Fresh Water Rinse cycle.

The brewer should begin to function normally as the solution is rinsed out and the scale is removed. If problem persists, allow brewer to sit unplugged for at least 30 minutes before continuing with the rinse.

# Troubleshooting

## Frother:

- For best froth performance, be sure the whisk is seated properly on the post in the bottom of the frother.
- Some separation of milk and froth can occur, especially if the froth is not poured right away. Pour the milk and scoop the froth into your beverage with a spoon if needed.
- If you are not satisfied with how your milk is frothing, please reference the How to Froth Like a Pro section of this guide for helpful hints. If you are still unsatisfied with your milk froth, please call Customer Service.
- If you are frothing the same milk twice, you may experience a shorter froth time, as the milk will have already reached the target temperature.
- If your milk frother is overflowing, be sure you are filling below the **MAX** fill line inside the frother.
- If your milk frother is scalding or burning the milk, be sure you are filling above the **MIN** fill line inside the frother. Additionally, be sure to clean residual milk at the bottom of the frother after each froth to avoid scalded milk.
- If the milk frother is not turning on, unplug your frother, wait 30 seconds, plug it back in, and try again. If it still does not work, call Customer Service.

**NOTE: Froth time will vary depending on the temperature of the milk.**

## Grounds in Your Coffee

Grounds may have gathered in the exit or entrance needles and can be cleaned using a straightened paper clip or similar tool.

- Clean the exit needle of the K-Cup® pod holder. Refer to the exit needle care instructions.
- Clean the brewer entrance needle. Refer to the entrance needle care instructions.

For optimal enjoyment and to limit grounds in your cup during hot water brews or when transitioning from brewing a coffee pod to a non-coffee pod (e.g., tea or cocoa), clean the exit and entrance needles per the instructions provided and perform two cleansing brews.

## Brewer Will Not Brew

- The water must be at a minimum level to brew. Add water to the **MAX** line, open and close the handle, and try to brew again.
- Lift up and replace the reservoir to ensure a secure fit on the base.

## Brewing a Partial Cup

- Unplug and plug the brewer back in. Remove and replace the water reservoir, ensuring a proper fit on the base.
- Clean the K-Cup® pod holder and unclog the needles, following the K-Cup® pod holder care instructions.
- The brewer may need to be descaled. If you have repeated the descale procedure on your brewer two times and it is still only brewing a partial cup, contact Customer Service.

## Brewer Does Not Have Power or Shuts Off

- Press any button or lift the brewer handle to turn on the brewer.
- Plug brewer into its own outlet. If the electric circuit is overloaded with other appliances, your brewer may not function properly. The brewer should be operated on its own circuit, separate from other appliances.
- For energy savings, the brewer automatically turns off 5 minutes after the last brew.
- If the brewer still doesn't have power, contact Customer Service.

## Helpful Hints

Water quality varies greatly. If you notice an undesirable taste in your beverage (such as chlorine or mineral tastes), we recommend using bottled or filtered water. Do not use distilled water.

## Service

Beyond these recommended cleaning and maintenance procedures, this brewer is not user serviceable. For service, please refer to the Warranty section of this guide.

## Storage

Empty the water reservoir before storing or transporting and take care to ensure that you store your brewer in a safe and frost-free environment. When you prepare to use it after storage, we recommend rinsing the water reservoir with fresh water and descaling the brewer as detailed in the Descaling Procedure section.

If you plan to move your brewer to a different location, turn the brewer off, unplug it, and empty the water reservoir. If your brewer has been in an environment below freezing, please be sure to let it warm to room temperature for at least 2 hours before using.

# Click or Call!

## Have Questions?

We're here to help.

Visit [support.keurig.com](http://support.keurig.com) for step-by-step videos on cleaning, descaling, and more.



## Still Need Help?

Give us a call at  
**1-866-901-BREW (2739).**

# Warranty

## LIMITED ONE-YEAR WARRANTY

Keurig Green Mountain, Inc. (Keurig) warrants that your brewer will be free of defects in materials or workmanship under normal home use for one year from the date of purchase. It is recommended that you register your brewer on [keurig.com/new](http://keurig.com/new) so that your purchase information will be stored in our system. Keurig will, at its option, repair or replace a defective brewer without charge upon receipt of proof of the date of purchase. If a replacement brewer is necessary to service this warranty, the replacement brewer may be new or reconditioned. If a replacement brewer is sent, a new limited one-year warranty will be applied to the replacement brewer.

This warranty only applies to brewers operated in the United States and Canada. This warranty gives you specific legal rights, and you may also have other rights that vary from state to state and, in the case of Canada, from province to province.

Only the use of Keurig® K-Cup® brand pods and accessories will guarantee the proper functioning and lifetime of your Keurig® brewer. Any damage to or malfunction of your brewer resulting from the use of non-Keurig® pods and accessories may not be covered by this warranty or may result in a service fee if the damage or malfunction is determined to be caused by such use.

## WHAT IS NOT COVERED BY THE LIMITED WARRANTY?

THIS WARRANTY DOES NOT COVER CONSEQUENTIAL OR INCIDENTAL DAMAGES SUCH AS PROPERTY DAMAGE AND DOES NOT COVER INCIDENTAL COSTS AND EXPENSES RESULTING FROM ANY BREACH OF THIS WARRANTY, EVEN IF FORESEEABLE. Some states or provinces do not allow the exclusion or limitation of incidental or consequential damages, so the above limitation or exclusion may not apply to you depending on the state or province of purchase.

Nor does this warranty cover damages caused by use of non-Keurig® pods or accessories, services performed by anyone other than Keurig or its authorized service providers, use of parts other than genuine Keurig® parts, or external causes such as abuse, misuse, inappropriate power supply, or acts of God.

## OTHER LIMITATIONS

THIS WARRANTY IS EXCLUSIVE AND IS IN LIEU OF ANY OTHER EXPRESS WARRANTY, WHETHER WRITTEN OR ORAL. IN ADDITION, KEURIG HEREBY SPECIFICALLY DISCLAIMS ALL OTHER WARRANTIES WITH RESPECT TO YOUR KEURIG® BREWER, INCLUDING ANY IMPLIED WARRANTY OF MERCHANTABILITY OR FITNESS FOR ANY PARTICULAR PURPOSE. Some states or provinces do not allow disclaimers of such implied warranties or limitations on how long an implied warranty lasts, so the above limitation may not apply to you depending on the state or the province of purchase.

## HOW DO YOU OBTAIN WARRANTY SERVICE?

Keurig® brewers are high-quality appliances and, with proper care, are intended to provide years of satisfying performance. However, should the need arise for warranty servicing, simply call Keurig Customer Service at our toll-free phone number, 1-866-901-BREW (2739). Please do not return your brewer for servicing without first speaking to Keurig Customer Service to obtain a Return Materials Authorization (RMA) number. Keurig® brewers returned without an RMA number will be returned to the sender without servicing.

# K·Café® Barista Bar

SINGLE SERVE COFFEE MAKER

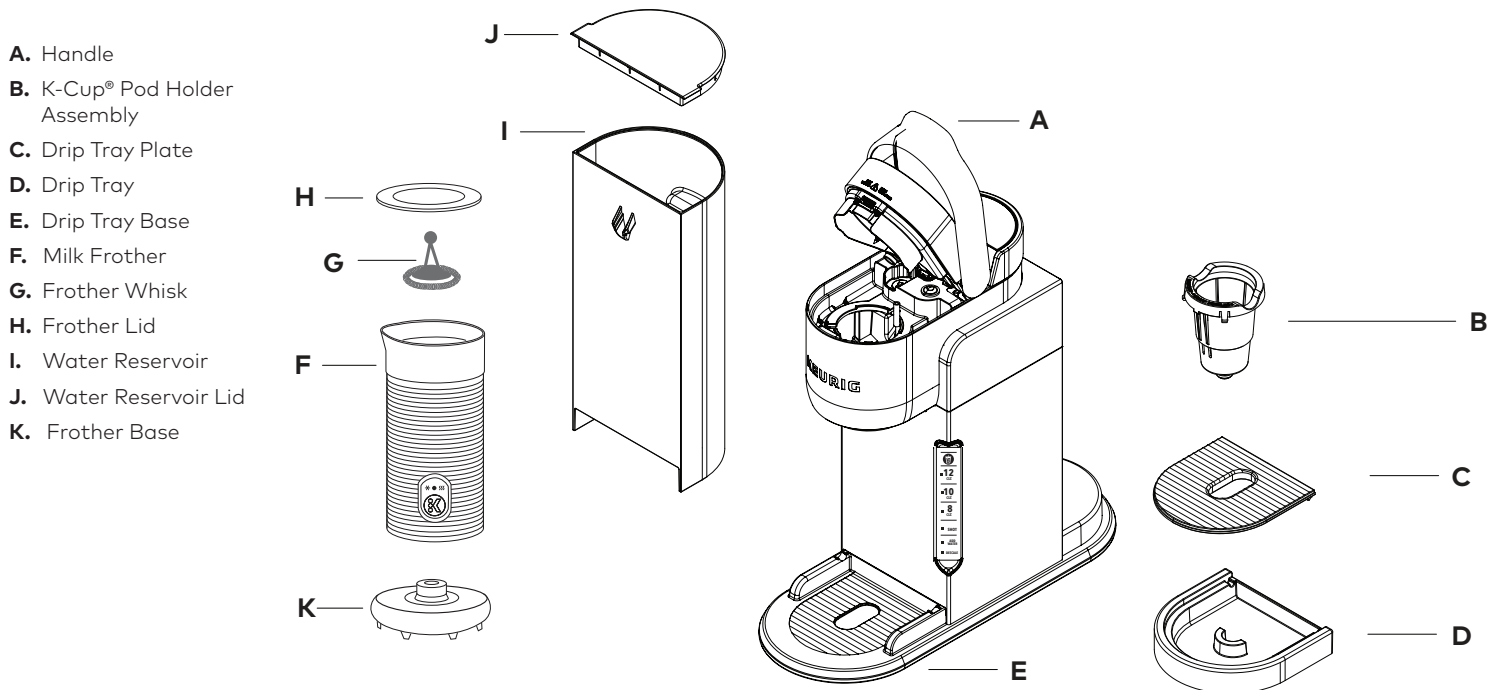

For replacement parts, please visit [www.keurig.com](http://www.keurig.com).

**Start your Keurig® experience by finding your favorite pods and registering your brewer**

[keurig.com/hello](http://keurig.com/hello)

**Have questions?** We're here to help. Visit [support.keurig.com](http://support.keurig.com) for troubleshooting videos, maintenance recommendations, and the full Use & Care Guide.

**Still need help?** Give us a call at 1-866-901-BREW (2739).